

FINAL  
DRAFT

INTERNATIONAL  
STANDARD

ISO/FDIS  
6182-1

ISO/TC 21/SC 5

Secretariat: ANSI

Voting begins on:  
2021-01-29

Voting terminates on:  
2021-03-26

---

---

## Fire protection — Automatic sprinkler systems —

### Part 1: Requirements and test methods for sprinklers

**iTeh STANDARD PREVIEW**  
(standards.iteh.ai)  
*Protection contre l'incendie — Systèmes d'extinction automatiques du type sprinkler —  
Partie 1: Prescriptions et méthodes d'essai des sprinklers*

ISO/FDIS 6182-1

<https://standards.iteh.ai/catalog/standards/sist/4730a0fb-c87c-493a-9571-f700f250fe1a/iso-fdis-6182-1>

RECIPIENTS OF THIS DRAFT ARE INVITED TO SUBMIT, WITH THEIR COMMENTS, NOTIFICATION OF ANY RELEVANT PATENT RIGHTS OF WHICH THEY ARE AWARE AND TO PROVIDE SUPPORTING DOCUMENTATION.

IN ADDITION TO THEIR EVALUATION AS BEING ACCEPTABLE FOR INDUSTRIAL, TECHNOLOGICAL, COMMERCIAL AND USER PURPOSES, DRAFT INTERNATIONAL STANDARDS MAY ON OCCASION HAVE TO BE CONSIDERED IN THE LIGHT OF THEIR POTENTIAL TO BECOME STANDARDS TO WHICH REFERENCE MAY BE MADE IN NATIONAL REGULATIONS.



Reference number  
ISO/FDIS 6182-1:2021(E)

© ISO 2021

**iTeh STANDARD PREVIEW**  
**(standards.iteh.ai)**

ISO/FDIS 6182-1

<https://standards.iteh.ai/catalog/standards/sist/4730a0fb-c87c-493a-9571-f700f250fe1a/iso-fdis-6182-1>



**COPYRIGHT PROTECTED DOCUMENT**

© ISO 2021

All rights reserved. Unless otherwise specified, or required in the context of its implementation, no part of this publication may be reproduced or utilized otherwise in any form or by any means, electronic or mechanical, including photocopying, or posting on the internet or an intranet, without prior written permission. Permission can be requested from either ISO at the address below or ISO's member body in the country of the requester.

ISO copyright office  
CP 401 • Ch. de Blandonnet 8  
CH-1214 Vernier, Geneva  
Phone: +41 22 749 01 11  
Email: [copyright@iso.org](mailto:copyright@iso.org)  
Website: [www.iso.org](http://www.iso.org)

Published in Switzerland

# Contents

	Page
<b>Foreword</b> .....	<b>vii</b>
<b>Introduction</b> .....	<b>viii</b>
<b>1 Scope</b> .....	<b>1</b>
<b>2 Normative references</b> .....	<b>1</b>
<b>3 Terms and definitions</b> .....	<b>1</b>
3.1 General.....	1
3.2 Types of sprinklers according to type of responsive element.....	4
3.3 Types of sprinkler according to type of water distribution.....	4
3.4 Types of sprinklers according to position.....	5
3.5 Special types of sprinklers.....	6
3.6 Types of sprinklers according to sprinkler sensitivity.....	7
<b>4 Product consistency</b> .....	<b>8</b>
4.1 Quality control programme.....	8
4.2 Leak resistance testing.....	8
4.3 Glass bulb integrity test.....	8
<b>5 Product assembly</b> .....	<b>8</b>
5.1 General.....	8
5.2 Dynamic O-ring seals.....	8
5.3 Rated pressure.....	8
5.4 Dry sprinklers.....	8
5.5 Escutcheons.....	8
<b>6 Requirements</b> .....	<b>9</b>
6.1 General.....	9
6.1.1 Electrically activated sprinkler and monitoring of activation.....	9
6.1.2 Orifice size.....	9
6.1.3 Nominal thread sizes.....	9
6.2 Maximum coverage areas and spacing.....	10
6.3 Temperature ratings and colour coding.....	10
6.4 Service load and strength of sprinkler body (see 7.4).....	11
6.5 Strength of heat-responsive element (see 7.5).....	11
6.5.1 Glass bulb elements.....	11
6.5.2 Fusible elements.....	12
6.6 Leak resistance and hydrostatic strength (see 7.6).....	12
6.7 Thirty-day leakage resistance (see 7.7).....	12
6.8 Vacuum resistance (see 7.8).....	12
6.9 Water hammer (see 7.9).....	12
6.10 Vibration (see 7.10).....	12
6.11 Deflector strength (see 7.11).....	12
6.12 Water shield rotation (see 7.12).....	12
6.13 Impact (see 7.13).....	13
6.14 Protective covers (see 7.14).....	13
6.15 Rough usage (see 7.15).....	13
6.16 Dry sprinkler air tightness (see 7.16).....	13
6.17 Operating temperature (see 7.17).....	13
6.18 Sensitivity — response time index (RTI) (see 7.18).....	14
6.18.1 Pre-exposure RTI.....	14
6.18.2 Post-exposure RTI.....	14
6.19 Sensitivity test of flush, concealed and recessed sprinklers (see 7.19).....	14
6.19.1 General.....	14
6.19.2 Room response test (see 7.19.2).....	14
6.19.3 Plunge test (see 7.19.3).....	15
6.20 Lodgement (see 7.20).....	16

6.21	Heat exposure (see <a href="#">7.21</a> )	16
6.21.1	Glass bulb sprinklers	16
6.21.2	All sprinklers	16
6.21.3	Coated sprinklers	16
6.22	Sprinkler coatings (see <a href="#">7.22</a> )	16
6.22.1	Evaporation of wax and bitumen	16
6.22.2	Resistance to low temperatures	16
6.23	Thermal shock for glass bulb sprinklers (see <a href="#">7.23</a> )	16
6.24	Resistance to heat (see <a href="#">7.24</a> )	17
6.25	Freezing test (see <a href="#">7.25</a> )	17
6.26	Corrosion (see <a href="#">7.26</a> )	17
6.26.1	Stress corrosion for copper-based alloy components (see <a href="#">7.26.1</a> )	17
6.26.2	Stress corrosion for stainless steel components (see <a href="#">7.26.2</a> )	17
6.26.3	Sulphur dioxide/carbon dioxide corrosion (see <a href="#">7.26.3</a> )	17
6.26.4	Hydrogen sulphide corrosion (see <a href="#">7.26.4</a> )	17
6.26.5	Salt spray loading (see <a href="#">7.26.5</a> )	18
6.26.6	Moist air exposure (see <a href="#">7.26.6</a> )	18
6.26.7	Dry-type sprinkler deposit loading (see <a href="#">7.26.7</a> )	18
6.26.8	Dezincification of brass parts (see <a href="#">7.26.8</a> )	18
6.27	Water flow constant (see <a href="#">7.27</a> )	18
6.28	Water distribution (see <a href="#">7.28</a> )	19
6.28.1	General	19
6.28.2	Spray, flat spray, conventional and dry sprinkler water distribution (see <a href="#">7.28.2</a> )	20
6.28.3	Domestic sprinkler water distribution (see <a href="#">7.28.3</a> )	21
6.28.4	Extended coverage light hazard sprinkler water distribution (see <a href="#">7.28.4</a> )	22
6.28.5	Extended coverage ordinary hazard sprinkler water distribution (see <a href="#">7.28.5</a> )	22
6.28.6	K202 and K242 pendent ESFR sprinkler water distribution (see <a href="#">7.28.6</a> )	23
6.28.7	Thrust force measurements for K202 and K242 pendent ESFR sprinklers (see <a href="#">7.28.7</a> )	25
6.29	Lateral discharge (see <a href="#">7.29</a> )	26
6.30	Water shield angle of protection (see <a href="#">7.30</a> )	26
6.31	Fire performance (see <a href="#">7.31</a> )	27
6.31.1	General	27
6.31.2	Spray sprinkler fire performance (see <a href="#">7.31.2</a> )	27
6.31.3	Domestic sprinkler fire performance (see <a href="#">7.31.3</a> )	28
6.31.4	Extended coverage light hazard sprinkler fire performance (see <a href="#">7.31.4</a> )	28
6.31.5	Extended coverage ordinary hazard sprinkler fire performance (see <a href="#">7.31.5</a> )	28
6.31.6	Nominal K-202 and K-242 pendent ESFR fire performance (see <a href="#">7.31.6</a> )	29
6.31.7	Standard coverage storage, extended coverage storage and ESFR (Other than K202 & K242 Pendent) sprinkler fire test performance (see <a href="#">7.31.7</a> )	30
6.32	Electrical characteristics	30
<b>7</b>	<b>Test methods</b>	<b>31</b>
7.1	General	31
7.2	Preliminary examination	31
7.3	Visual examination	31
7.4	Service load and strength of sprinkler body test (see <a href="#">6.4</a> )	31
7.4.1	Test option 1	31
7.4.2	Test option 2	32
7.4.3	Test option 3	32
7.5	Strength of heat-responsive element test (see <a href="#">6.5</a> )	33
7.5.1	Glass bulbs	33
7.5.2	Fusible elements	33
7.6	Leak resistance and hydrostatic strength tests (see <a href="#">6.6</a> )	33
7.7	Thirty-day leakage test (see <a href="#">6.7</a> )	34
7.8	Vacuum test (see <a href="#">6.8</a> )	34
7.9	Water hammer test (see <a href="#">6.9</a> )	34
7.10	Vibration test (see <a href="#">6.10</a> )	34

7.11	Deflector strength test (see 6.11)	34
7.12	Water shield rotation test (see 6.12)	35
7.13	Impact (see 6.13)	35
7.14	Protective cover impact test for glass bulb sprinklers (see 6.14)	36
7.15	Rough usage test (see 6.15)	37
7.16	Dry sprinkler air tightness test (see 6.16)	38
7.17	Operating temperature tests (see 6.17)	39
	7.17.1 Liquid test	39
	7.17.2 Air test	40
7.18	Sensitivity test — response time index (RTI) (see 6.18)	41
	7.18.1 Plunge test	41
	7.18.2 RTI calculation	42
7.19	Sensitivity test for flush, concealed and recessed sprinklers (see 6.19)	42
	7.19.1 General	42
	7.19.2 Room response test	42
	7.19.3 Plunge test	47
7.20	Lodgement test (see 6.20)	50
7.21	Heat exposure test (see 6.21)	53
	7.21.1 Glass bulb sprinklers (see 6.21.1)	53
	7.21.2 All sprinklers (see 6.21.2)	53
	7.21.3 Coated sprinklers (see 6.21.3)	53
7.22	Sprinkler coatings (see 6.22)	54
	7.22.1 Evaporation of wax and bitumen test (see 6.22.1)	54
	7.22.2 Low temperature test (see 6.22.2)	54
7.23	Thermal shock test for glass bulb sprinklers (see 6.23)	54
7.24	Resistance to heat test (see 6.24)	54
7.25	Freezing (see 6.25)	54
7.26	Corrosion tests (see 6.26)	55
	7.26.1 Stress corrosion test for copper-based alloy components (see 6.26.1)	55
	7.26.2 Stress corrosion for stainless steel components (see 6.26.2)	55
	7.26.3 Sulphur dioxide/carbon dioxide corrosion test (see 6.26.3)	56
	7.26.4 Hydrogen sulphide corrosion test (see 6.26.4)	56
	7.26.5 Salt spray loading test (see 6.26.5)	57
	7.26.6 Moist air exposure (see 6.26.6)	57
	7.26.7 Dry-type sprinkler deposit loading test (see 6.26.7)	57
	7.26.8 Dezincification of brass components (see 6.26.8)	58
7.27	Water flow constant (see 6.27)	59
7.28	Water distribution tests (see 6.28)	60
	7.28.1 General	60
	7.28.2 Spray, flat spray, conventional and dry sprinklers (see 6.28.2)	60
	7.28.3 Domestic sprinklers (see 6.28.3)	68
	7.28.4 Extended coverage light hazard sprinklers (see 6.28.4)	72
	7.28.5 Extended coverage ordinary hazard sprinklers (see 6.28.5)	78
	7.28.6 K202 and K242 pendent ESFR sprinklers (see 6.28.6)	78
	7.28.7 Thrust force test (see 6.28.7)	83
7.29	Lateral discharge test (see 6.29)	84
	7.29.1 General	84
	7.29.2 Upright and pendent sprinklers	84
	7.29.3 Sidewall sprinklers	85
	7.29.4 Exposure to heat and flame	85
	7.29.5 Consumption of heptane	85
7.30	Water shield angle of protection (see 6.30)	85
7.31	Fire performance (see 6.31)	86
	7.31.1 General	86
	7.31.2 Spray sprinkler fire performance	86
	7.31.3 Domestic sprinkler fire performance (see 6.31.3)	89
	7.31.4 Extended coverage light hazard sprinkler fire performance (see 6.31.4)	96
	7.31.5 Extended coverage ordinary hazard sprinkler fire performance (see 6.31.5)	99

7.31.6	Actual delivered density (nominal K-202 and K-242 pendent ESFR fire performance) (see <a href="#">6.31.6</a> ).....	100
7.31.7	Standard coverage storage, extended coverage storage and ESFR (other than K202 & K242 pendent) sprinkler fire test performance (see <a href="#">6.31.7</a> ).....	101
7.32	Electrical characteristics.....	103
7.32.1	Starting current and response time (see <a href="#">6.32.1</a> ).....	103
7.32.2	Monitoring current (see <a href="#">6.32.2</a> ).....	103
7.32.3	Wires ( <a href="#">6.32.3</a> ).....	103
<b>8</b>	<b>Marking</b> .....	<b>103</b>
8.1	Sprinklers.....	103
8.2	Sprinkler housings and concealed-sprinkler cover plates.....	105
8.3	Protective covers.....	105
<b>9</b>	<b>Manufacturer's installation instructions</b> .....	<b>105</b>
<b>Annex A (normative) Tolerance limit calculation methods</b> .....		<b>109</b>
<b>Annex B (informative) Analysis of the strength test for fusible element</b> .....		<b>111</b>
<b>Annex C (normative) Tolerances</b> .....		<b>112</b>
<b>Annex D (Informative) Standard test commodities and fire test configurations</b> .....		<b>113</b>
<b>Annex E (Informative) Fire test arrangements for extended coverage ordinary hazard</b> .....		<b>118</b>
<b>Annex F (informative) Statistical tolerance limits</b> .....		<b>121</b>
<b>Bibliography</b> .....		<b>124</b>

**ITeH STANDARD PREVIEW**  
**(standards.iteh.ai)**

<https://standards.iteh.ai/catalog/standards/sist/4730a0fb-c87c-493a-9571-f700f250fe1a/iso-fdis-6182-1>

## Foreword

ISO (the International Organization for Standardization) is a worldwide federation of national standards bodies (ISO member bodies). The work of preparing International Standards is normally carried out through ISO technical committees. Each member body interested in a subject for which a technical committee has been established has the right to be represented on that committee. International organizations, governmental and non-governmental, in liaison with ISO, also take part in the work. ISO collaborates closely with the International Electrotechnical Commission (IEC) on all matters of electrotechnical standardization.

The procedures used to develop this document and those intended for its further maintenance are described in the ISO/IEC Directives, Part 1. In particular, the different approval criteria needed for the different types of ISO documents should be noted. This document was drafted in accordance with the editorial rules of the ISO/IEC Directives, Part 2 (see [www.iso.org/directives](http://www.iso.org/directives)).

Attention is drawn to the possibility that some of the elements of this document may be the subject of patent rights. ISO shall not be held responsible for identifying any or all such patent rights. Details of any patent rights identified during the development of the document will be in the Introduction and/or on the ISO list of patent declarations received (see [www.iso.org/patents](http://www.iso.org/patents)).

Any trade name used in this document is information given for the convenience of users and does not constitute an endorsement.

For an explanation of the voluntary nature of standards, the meaning of ISO specific terms and expressions related to conformity assessment, as well as information about ISO's adherence to the World Trade Organization (WTO) principles in the Technical barriers to Trade (TBT), see [www.iso.org/iso/foreword.html](http://www.iso.org/iso/foreword.html).

This document was prepared by Technical Committee ISO/TC 21, *Equipment for fire protection and fire fighting*, Subcommittee SC 5, *Fixed firefighting systems using water*.

This fourth edition cancels and replaces the third edition (ISO 6182-1:2014) which has been technically revised.

The main changes compared to the previous edition are as follows:

- Consolidation of the requirements for early suppression fast response (ESFR) sprinklers (ISO 6182-7:2020), domestic sprinklers (ISO 6182-10:2014) and extended coverage sprinklers (ISO 6182-13:2017) into a single document.
- Increased harmonization of test methods and requirements for the different types of sprinklers.
- Expanded scope to include extended coverage sprinklers for ordinary hazard occupancies and large K-factor storage type sprinklers.
- New water distribution and fire test methods as well as requirements for the additional sprinkler technologies.
- New requirements for electrically operated style sprinklers.

A list of all parts in the ISO 6182 series can be found on the ISO website.

Any feedback or questions on this document should be directed to the user's national standards body. A complete listing of these bodies can be found at [www.iso.org/members.html](http://www.iso.org/members.html).

## Introduction

This document includes requirements for conventional, spray, flat spray, sidewall, extended coverage, domestic and storage sprinklers, including early suppression fast response (ESFR) sprinklers, electrically activated sprinklers (EAS) and sprinklers with monitoring of activation (SMA).

Conventional sprinklers are the oldest of the fire sprinkler technologies. These sprinklers discharge water in a spherical discharge pattern such that 40 % to 60 % of the total water flow is initially discharged in the downward direction. In general, the use of this sprinkler technology is limited to applications where this discharge characteristic has been determined to be more effective than the spray sprinkler.

Spray sprinklers were developed in the 1950s and are used to provide fire protection for a wide range of fire risks, including those found in light hazard, ordinary hazard and extra hazard occupancies, as well as storage facilities.

Flat spray sprinklers have a wider spray angle than spray sprinklers and are generally limited to use in spaces with low clearances and storage racks in specific geographic regions.

Domestic sprinklers are intended to provide control of fires in domestic occupancies, to prevent flashover (total involvement) in the room of fire origin and to improve the probability for successful escape or evacuation of the occupants.

Extended coverage light hazard sprinklers are intended to provide control of fires in occupancies or portions of occupancies where quantity and/or combustibility of contents is low, such as office spaces.

Extended coverage ordinary hazard sprinklers are intended to provide control of fires in occupancies or portions of occupancies where quantity and/or combustibility of contents is moderate to high, such as mercantile areas.

Storage sprinklers, including ESFR sprinklers, are primarily intended to be used to provide fire protection for storage facilities.

Electrically activated sprinklers make it possible to activate more than one sprinkler simultaneously.

Sprinklers with monitoring of activation make it possible to detect the location of an actuated sprinkler.



# Fire protection — Automatic sprinkler systems —

## Part 1: Requirements and test methods for sprinklers

### 1 Scope

This document specifies performance and marking requirements and test methods for conventional, spray, flat spray, sidewall, extended coverage, domestic and storage sprinklers, including early suppression fast response (ESFR), electrically activated sprinklers (EAS) and sprinklers with monitoring of activation (SMA) for use in water-based fire protection systems. This document is not applicable to sprinklers with multiple orifices.

### 2 Normative references

The following documents are referred to in the text in such a way that some or all of their content constitutes requirements of this document. For dated references, only the edition cited applies. For undated references, the latest edition of the referenced document (including any amendments) applies.

ISO 7-1, *Pipe threads where pressure-tight joints are made on the threads — Part 1: Dimensions, tolerances and designation*

ISO 5660-1, *Reaction-to-fire tests — Heat release, smoke production and mass loss rate — Part 1: Heat release rate (cone calorimeter method) and smoke production rate (dynamic measurement)*

### 3 Terms and definitions

For the purposes of this document, the following terms and definitions apply.

ISO and IEC maintain terminological databases for use in standardization at the following addresses:

- ISO Online browsing platform: available at <https://www.iso.org/obp>
- IEC Electropedia: available at <http://www.electropedia.org/>

#### 3.1 General

##### 3.1.1

##### **actual delivered density**

##### **ADD**

rate at which water is deposited from an operating *sprinkler* (3.1.13) onto the top horizontal surface of a simulated burning combustible array

##### 3.1.2

##### **assembly load**

force exerted on the sprinkler body excluding hydrostatic pressure

##### 3.1.3

##### **average design strength**

glass bulb supplier's specified and assured lowest average axial design strength of any batch of 50 bulbs

3.1.4

**coverage length**

maximum length of the sprinkler coverage area

3.1.5

**coverage width**

maximum width of the sprinkler coverage area

3.1.6

**design load**

force exerted on the release element at the *service load* (3.1.12) of the *sprinkler* (3.1.13)

3.1.7

**housing assembly**

**escutcheon**

ornamental or protective component(s) around the hole from which the *sprinkler* (3.1.13) penetrates the plane of the ceiling or the wall

Note 1 to entry: See [Figure 3](#).

Note 2 to entry: For the purposes of this document, housing applies to recessed and *concealed sprinklers* (3.5.2).

3.1.8

**orientation A**

orientation with the airflow perpendicular to both the waterway axis and the plane of the frame arms and with the heat responsive element upstream of the frame arms

Note 1 to entry: See [Figure 1](#).

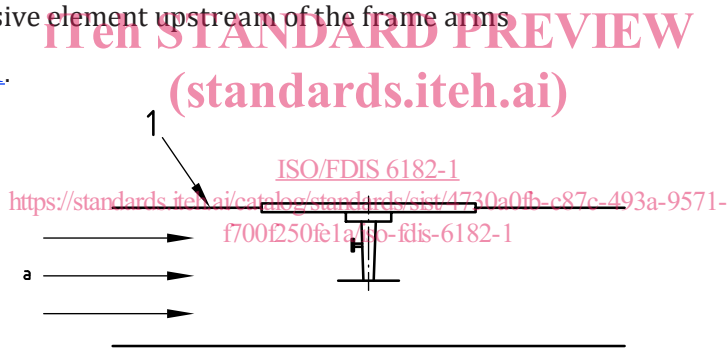

**Key**

1 tunnel test section (elevation view)

a Airflow.

**Figure 1 — Orientation A**

3.1.9

**orientation B**

orientation with the airflow perpendicular to both the waterway axis and the plane of the frame arms and with the heat responsive element downstream of the frame arms

Note 1 to entry: See [Figure 2](#).

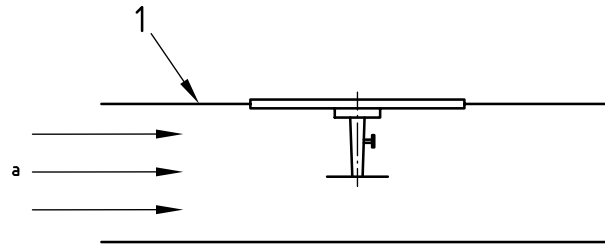
**Key**

- 1 tunnel test section (elevation view)  
 a Airflow.

**Figure 2 — Orientation B**

### 3.1.10 protective covers

protective caps or straps intended to provide temporary protection for *sprinklers* (3.1.13) during shipping, handling and installation

### 3.1.11 response time index

**RTI**

measure of sprinkler sensitivity determined by [Formula \(1\)](#)

$$RTI = t\sqrt{u} \quad (1)$$

where

- $t$  is equal to the time constant, in seconds, of the heat-responsive element;  
 $u$  is the gas velocity, in meters per second.

Note 1 to entry: The response time index is expressed in units of (m·s)<sup>0.5</sup>.

### 3.1.12 service load

combined force exerted on the sprinkler body by the *assembly load* (3.1.2) of the *sprinkler* (3.1.13) and the equivalent force of the rated pressure on the inlet

### 3.1.13 sprinkler

thermosensitive device designed to react at a predetermined temperature by automatically releasing a stream of water and distributing it in a specified pattern and quantity over a designated area

Note 1 to entry: These devices may sometimes be referred to as a sprinkler head.

### 3.1.14 standard orientation

orientation that produces the shortest response time with the axis of the sprinkler inlet perpendicular to the airflow

Note 1 to entry: In the case of symmetrical heat-responsive elements, standard orientation is with the airflow perpendicular to both the axis of the waterway and the plane of the frame arms; in the case of non-symmetrical heat-responsive elements, it is with the airflow perpendicular to both the waterway axis and the plane of the frame arms which produces the shortest response time.

## 3.2 Types of sprinklers according to type of responsive element

### 3.2.1

#### electrically activated sprinkler

##### EAS

*sprinkler* (3.1.13) that is equipped with an integral means of activation using electricity

### 3.2.2

#### sprinklers with monitoring of activation

##### SMA

*sprinkler* (3.1.13) that is equipped with an integral means of monitoring of activation using electricity

### 3.2.3

#### electrically activated sprinkler with monitoring of activation

##### EAS-M

*sprinkler* (3.1.13) that is equipped with an integral means of activation using electricity and monitoring of activation

### 3.2.4

#### fusible element sprinkler

*sprinkler* (3.1.13) that opens under the influence of heat by the melting of a component

### 3.2.5

#### glass bulb sprinkler

*sprinkler* (3.1.13) that opens under the influence of heat by the bursting of the glass bulb through pressure resulting from expansion of the fluid enclosed therein

## 3.3 Types of sprinkler according to type of water distribution

### 3.3.1

#### conventional sprinkler

<https://standards.iteh.ai/catalog/standards/sist/4730a0fb-c87c-493a-9571-f700f250fe1a/iso-fdis-6182-1>

*sprinkler* (3.1.13) giving spherical water distribution directed downward and at the ceiling for a definite protection area such that 40 % to 60 % of the total water flow is initially directed downward

### 3.3.2

#### flat spray sprinkler

##### F

*sprinkler* (3.1.13) giving water distribution directed downward for a definite protection area such that 85 % to 100 % of the total water flow is initially directed downward with a wider spray angle than expected with a *spray sprinkler* (3.3.3)

Note 1 to entry: This type of sprinkler is used in storage racks and other shallow areas in some countries.

### 3.3.3

#### spray sprinkler

##### S

*sprinkler* (3.1.13) giving paraboloid water distribution directed downward for a definite protection area such that 80 % to 100 % of the total water flow is initially directed downward

### 3.3.4

#### domestic sprinkler

##### D

*sprinkler* (3.1.13) intended to provide control of fire in domestic occupancies

### 3.3.5

#### extended coverage sprinkler

##### EC

*sprinkler* (3.1.13) with a specified area of coverage which is larger than the standard sprinkler coverage areas

**3.3.5.1****extended coverage light hazard sprinkler****ECLH**

*sprinkler* (3.1.13) having a specified area of coverage which is larger than the standard sprinkler coverage areas and intended for use in occupancies or portions of occupancies where the quantity and/or combustibility of contents is low, such as office spaces

**3.3.5.2****extended coverage ordinary hazard sprinkler****ECOH**

*sprinkler* (3.1.13) having a specified area of coverage which is larger than the standard sprinkler coverage areas and intended for use in occupancies or portions of occupancies where the quantity and/or combustibility of contents is moderate to high

**3.3.5.3****extended coverage storage sprinkler****ECSS**

*sprinkler* (3.1.13) having a specified area of coverage which is larger than the standard sprinkler coverage areas and intended to protect stockpiles of commodities in building structures, such as storage facilities

**3.3.6****standard coverage storage sprinkler****SCSS**

*sprinkler* (3.1.13) having a standard area of coverage (typically 9 m<sup>2</sup> maximum) and intended to protect stockpiles of commodities in building structures, such as storage facilities

**3.3.7****early suppression fast response automatic sprinkler****ESFR**

*sprinkler* (3.1.13) that is intended to provide early suppression of a fire when protecting stockpiles of commodities in building structures such as storage facilities

**3.4 Types of sprinklers according to position****3.4.1****horizontal sidewall sprinkler****H**

*sprinkler* (3.1.13) arranged such that the orifice directs the water stream horizontally towards the deflector giving a one-sided distribution pattern

**3.4.2****pendent sprinkler****P**

*sprinkler* (3.1.13) arranged such that the orifice directs the water stream downwards towards the deflector

**3.4.3****vertical sidewall sprinkler****W**

*sprinkler* (3.1.13) arranged such that the orifice directs the water stream upwards or downwards towards the deflector giving a one-sided water distribution

**3.4.4****upright sprinkler****U**

*sprinkler* (3.1.13) arranged such that the orifice directs the water stream upwards towards the deflector

### 3.5 Special types of sprinklers

#### 3.5.1

##### coated sprinkler

sprinkler (3.1.13) that has a factory-applied coating for corrosion protection

Note 1 to entry: For this document coated sprinkler does not include coatings intended for aesthetic purposes.

#### 3.5.2

##### concealed sprinkler

recessed sprinkler (3.5.6) having a cover plate

Note 1 to entry: See Figure 3 a).

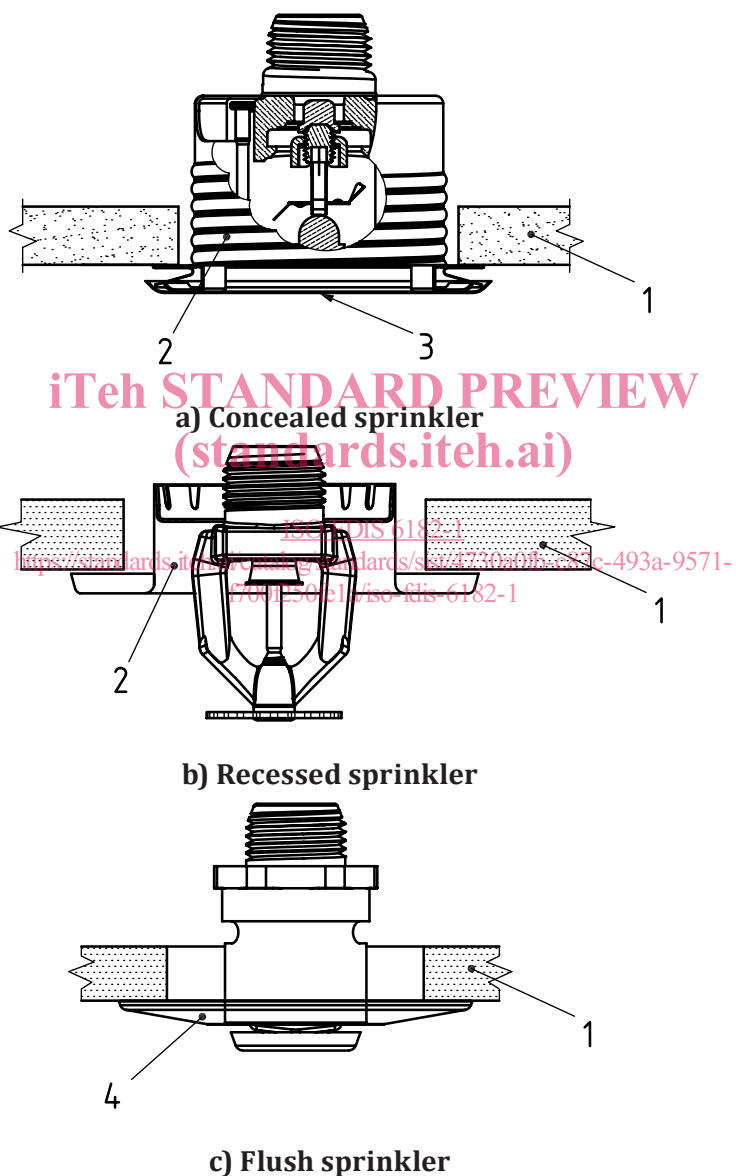

#### Key

- 1 ceiling
- 2 housing assembly
- 3 cover plate
- 4 escutcheon

Figure 3 — Flush, concealed, and recessed sprinklers

### 3.5.3

#### **dry sprinkler**

assembly comprising of a *sprinkler* (3.1.13) mounted at the outlet of a special extension with a seal at the inlet that prevents water from entering the extension until it is released by operation of the sprinkler

Note 1 to entry: These sprinklers may consist of pendent, upright, sidewall and other types.

### 3.5.4

#### **flush sprinkler**

for *pendent sprinklers* (3.4.2), all or part of the body is mounted above the lower plane of the ceiling, but all of the heat-responsive collector is below the lower plane of the ceiling; for sidewall sprinklers, the sprinkler is within the wall, but the heat-responsive collector projects into the room beyond the plane of the wall

Note 1 to entry: See [Figure 3 c](#)).

Note 2 to entry: These are not typically frame arm sprinklers.

[SOURCE: ISO 6182-1:2014, 3.5.4, modified — Notes to entry added]

### 3.5.5

#### **multiple orifice sprinkler**

*sprinkler* (3.1.13) having two or more outlet orifices arranged to distribute the water discharge in a specified pattern and quantity for a definite protection area

Note 1 to entry: Multiple orifice sprinklers are not included in the scope of this document.

### 3.5.6

#### **recessed sprinkler**

*sprinkler* (3.1.13) of which all or part of the body, other than the thread, is mounted within a recessed housing

Note 1 to entry: See [Figure 3 b](#)). <https://standards.iteh.ai/catalog/standards/sist/4730a0fb-c87c-493a-9571-f700f250fe1a/iso-fdis-6182-1>

### 3.5.7

#### **sprinkler with water shield**

*sprinkler* (3.1.13), intended for use in racks or beneath open grating, which is provided with a water shield mounted above the heat-responsive element to protect it from water discharged by sprinklers at higher elevations

Note 1 to entry: Sprinklers with water shields may be a single unit that is assembled by the manufacturer or a combination of sprinkler and water shield (which in some countries are evaluated separately from the sprinkler approval) assembled on site.

## 3.6 Types of sprinklers according to sprinkler sensitivity

### 3.6.1

#### **fast-response sprinkler**

*sprinkler* (3.1.13) with a *response time index* (3.1.11) (RTI)  $\leq 50 \text{ (m}\cdot\text{s)}^{0,5}$  as determined in 6.18 or for *flush* (3.5.4), *concealed* (3.5.2) and *recessed sprinklers* (3.5.6), a maximum response time as determined in 6.19

### 3.6.2

#### **special-response sprinkler**

*sprinkler* (3.1.13) with an average *response time index* (RTI) (3.1.11) of between  $50 \text{ (m}\cdot\text{s)}^{0,5}$  and  $80 \text{ (m}\cdot\text{s)}^{0,5}$

### 3.6.3

#### **standard-response sprinkler**

*sprinkler* (3.1.13) with a *response time index* (RTI) (3.1.11) of between  $80 \text{ (m}\cdot\text{s)}^{0,5}$  and  $350 \text{ (m}\cdot\text{s)}^{0,5}$  as determined in 6.18 or for *flush* (3.5.4), *concealed* (3.5.2) and *recessed sprinklers* (3.5.6), a maximum response time as determined in 6.19