



~~Designation: B557-06~~ Designation: B557 - 10

# Standard Test Methods for Tension Testing Wrought and Cast Aluminum- and Magnesium-Alloy Products<sup>1</sup>

This standard is issued under the fixed designation B557; the number immediately following the designation indicates the year of original adoption or, in the case of revision, the year of last revision. A number in parentheses indicates the year of last reapproval. A superscript epsilon ( $\epsilon$ ) indicates an editorial change since the last revision or reapproval.

*This standard has been approved for use by agencies of the Department of Defense.*

## 1. Scope\*

1.1 These test methods cover the tension testing of wrought and cast aluminum- and magnesium-alloy products, excepting aluminum foil<sup>2</sup>, and are derived from Test Methods E8, which cover the tension testing of all metallic materials.

1-2

1.2 The values stated in inch-pound units are to be regarded as standard. No other units of measurement are included in this standard.

1.3 *This standard does not purport to address all of the safety concerns, if any, associated with its use. It is the responsibility of the user of this standard to establish appropriate safety and health practices and determine the applicability of regulatory limitations prior to use.*

NOTE 1—Exceptions to the provisions of these test methods may need to be made in individual specifications or test methods for a particular material.

NOTE 2—A complete metric companion to Test Methods B557 has been developed—Test Methods B557M; therefore, no metric equivalents are presented in these test methods.

## 2. Referenced Documents

2.1 The following documents of the issue in effect on the date of material purchase form a part of these test methods to the extent referenced herein:

2-2

2.1 *ASTM Standards:*<sup>3</sup>

B209 Specification for Aluminum and Aluminum-Alloy Sheet and Plate

E4 Practices for Force Verification of Testing Machines

E6 Terminology Relating to Methods of Mechanical Testing

E8 Test Methods for Tension Testing of Metallic Materials

E29 Practice for Using Significant Digits in Test Data to Determine Conformance with Specifications

E83 Practice for Verification and Classification of Extensometer Systems

E345 Test Methods of Tension Testing of Metallic Foil

E691 Practice for Conducting an Interlaboratory Study to Determine the Precision of a Test Method

E1012 Practice for Verification of Test Frame and Specimen Alignment Under Tensile and Compressive Axial Force Application

## 3. Terminology

3.1 The definitions of terms relating to tension testing appearing in Terminology E6 shall be considered as applying to the terms used in these test methods.

## 4. Significance and Use

4.1 Tension tests provide information on the strength and ductility of materials under uniaxial tensile stresses. This information may be useful in comparisons of materials, alloy development, quality control, and design under certain circumstances.

4.2 The results of tension tests of specimens machined to standardized dimensions from selected portions of a part or material

<sup>1</sup> These test methods are under the jurisdiction of ASTM Committee B07 on Light Metals and Alloys and are the direct responsibility of Subcommittee B07.05 on Testing. Current edition approved May/July 1, 2006; 2010. Published May-2006; August 2010. Originally approved in 1971. Last previous edition approved in 2002 as B557-02a; B557-06. DOI: 10.1520/B0557-106.

<sup>2</sup> For test methods of tension testing of aluminum foil, see Test Methods E345.

<sup>3</sup> For referenced ASTM standards, visit the ASTM website, www.astm.org, or contact ASTM Customer Service at service@astm.org. For *Annual Book of ASTM Standards* volume information, refer to the standard's Document Summary page on the ASTM website.

\*A Summary of Changes section appears at the end of this standard.

may not totally represent the strength and ductility properties of the entire end product or its in-service behavior in different environments.

4.3 These test methods are considered satisfactory for acceptance testing of commercial shipments and have been used extensively in the trade for this purpose.

## 5. Apparatus

5.1 *Testing Machines*—Machines used for tension testing shall conform to the requirements of Practices E4. The forces used in determining tensile strength and yield strength shall be within the verified force application range of the testing machine as defined in Practices E4.

### 5.2 *Gripping Devices:*

5.2.1 *General*—Various types of gripping devices may be used to transmit the measured load applied by the testing machine to the test specimens. To ensure axial tensile stress within the gage length, the axis of the test specimen must coincide with the centerline of the heads of the testing machine. Any departure from this requirement may introduce bending stresses that are not included in the usual stress computation (load divided by cross-sectional area).

NOTE 3—The effect of this eccentric loading may be illustrated by calculating the bending moment and stress thus added. For a standard 0.500-in. diameter specimen, the stress increase is 1.5 percentage points for each 0.001 in. of eccentricity. This error increases to 2.24 percentage points/0.001 in. for a 0.350-in. diameter specimen and to 3.17 percentage points/0.001 in. for a 0.250-in. diameter specimen.

NOTE 4—Alignment methods are given in Practice E1012.

5.2.2 *Wedge Grips*—Testing machines usually are equipped with wedge grips. These wedge grips generally furnish a satisfactory means of gripping long specimens of ductile metal. If, however, for any reason, one grip of a pair advances farther than the other as the grips tighten, an undesirable bending stress may be introduced. When liners are used behind the wedges, they must be of the same thickness and their faces must be flat and parallel. For best results, the wedges should be supported over their entire length by the heads of the testing machine. This requires that liners of several thicknesses be available to cover the range of specimen thickness. For proper gripping, it is desirable that the entire length of the serrated face of each wedge be in contact with the specimen. Proper alignment of wedge grips and liners is illustrated in Fig. 1. For short specimens it is generally necessary to use machined test specimens and to use a special means of gripping to ensure that the specimens, when under load, shall be as nearly as possible in uniformly distributed pure axial tension (see 5.2.3, 5.2.4, and 5.2.5).

5.2.3 *Grips for Threaded and Shouldered Specimens*—A schematic diagram of a gripping device for threaded-end specimens is shown in Fig. 2, while Fig. 3 shows a device for gripping specimens with shouldered ends. Both of these gripping devices should be attached to the heads of the testing machine through properly lubricated spherical-seated bearings. The distance between spherical bearings should be as great as feasible.

5.2.4 *Grips for Sheet Materials*—The self-adjusting grips shown in Fig. 4 have proved satisfactory for testing sheet materials that cannot be tested satisfactorily in the usual type of wedge grips.

5.2.5 *Grips for Wire*—Grips of either the wedge or snubbing types as shown in Fig. 4 and Fig. 5 or flat wedge grips may be used.

5.3 *Dimension-Measuring Devices*—Micrometers and other devices used for measuring linear dimensions shall be accurate and precise to at least one half the smallest unit to which the individual dimension is required to be measured.

5.4 *Extensometers*—Extensometers used in tensile testing shall conform to the requirements of Practice E83 for the classifications specified by the procedure section of these test methods. Extensometers shall be used and verified to include the strains corresponding to the yield strength and elongation at fracture (if determined).

5.4.1 Extensometers with gage lengths equal to or shorter than the nominal gage length of the specimen (dimension shown as “G-Gage Length” in the accompanying figures) may be used to determine the yield behavior. For measuring elongation at fracture with an appropriate extensometer, the gage length of the extensometer shall be equal to the nominal gage length required for the specimen being tested.

## 6. Test Specimen

### 6.1 *General:*

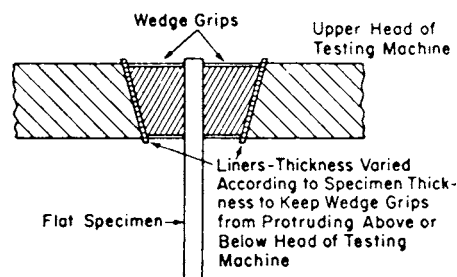

FIG. 1 Wedge Grips with Liners for Flat Specimens

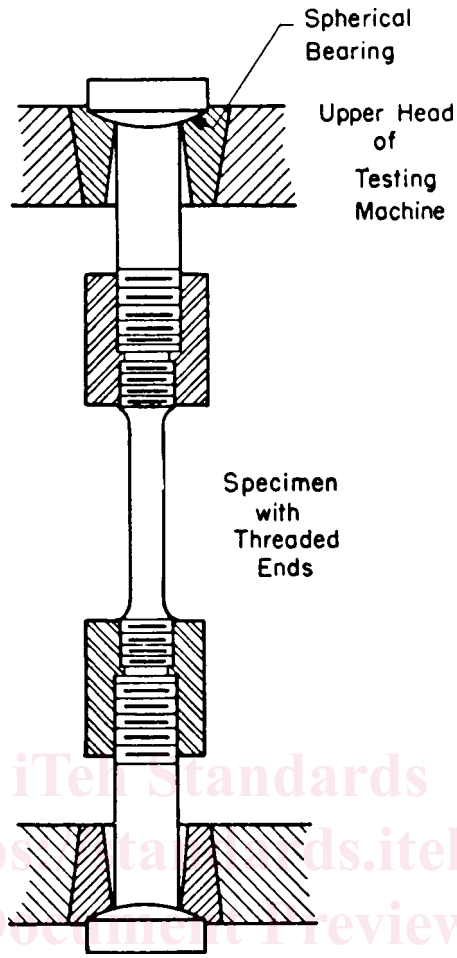

FIG. 2 Gripping Device for Threaded-End Specimens

ASTM B557-10  
<https://standards.iteh.ai/catalog/standards/sist/148b312a-1181-4832-1c3eb8979a38/astm-b557-10>

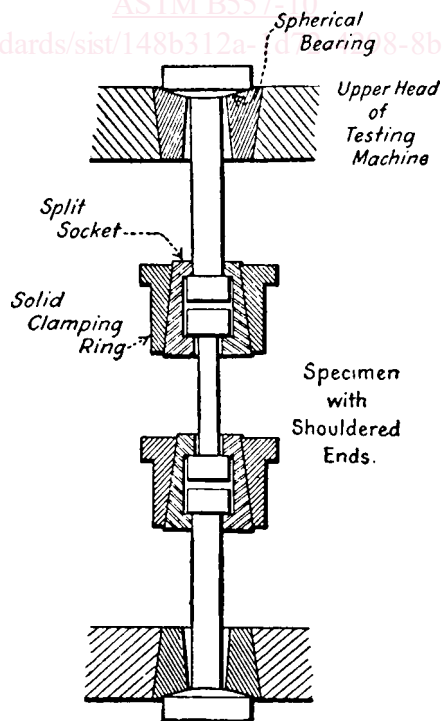

FIG. 3 Gripping Device for Shouldered-End Specimens

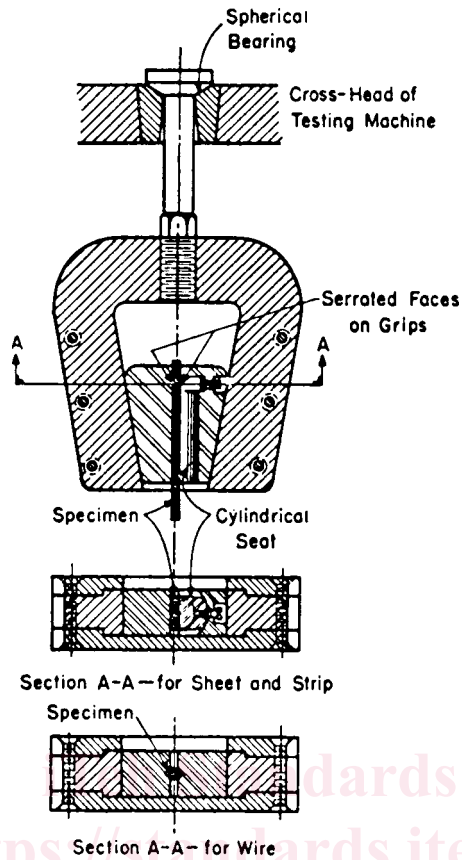

FIG. 4 Gripping Devices for Sheet and Wire Specimens

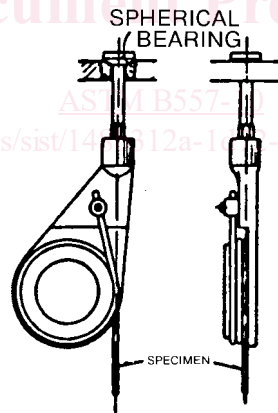

FIG. 5 Snubbing Device for Testing Wire

6.1.1 Test specimens shall be of the full section of the material whenever practical. Otherwise, machined specimens of rectangular or round cross section shall be used.

6.1.2 Improperly prepared test specimens often are the reason for unsatisfactory and incorrect test results. It is important, therefore, that care be exercised in the preparation of specimens, particularly in the machining, to ensure the desired precision and bias in test results.

6.1.3 The cross-sectional area of the specimen should be smallest at the center of the reduced section to ensure fracture within the gage length. For this reason, a small taper is permitted in the reduced section of each of the specimens described in the following sections.

6.1.4 Rectangular specimens shall be 0.500 in. wide in accordance with Fig. 6 or Fig. 7 (for tubular products), and shall be of the full thickness of the material when practical. When necessary, 0.250-in. wide subsize specimens as shown in Fig. 6 may be used, but elongation values from such specimens are not applicable to specification requirements.

6.1.4.1 Pin ends as shown in Fig. 8 may be used. In order to avoid buckling in tests of thin and high-strength materials, it may be necessary to use stiffening plates at the grip ends.

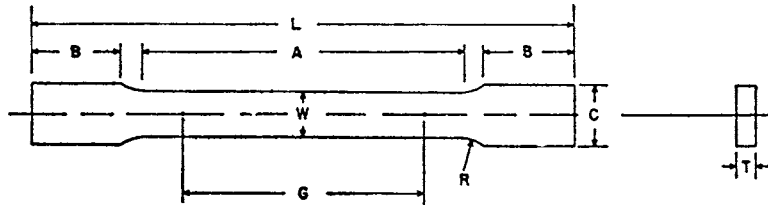

Dimensions, in.

	Standard Specimen Sheet-Type, 1/2-in. Wide	Subsize Specimen 1/4-in. Wide
G—Gage length	2.000 ± 0.005	1.000 ± 0.003
W—Width (Note 1 and Note 2)	0.500 ± 0.010	0.250 ± 0.002
T—Thickness (Note 3)	thickness of material	thickness of material
R—Radius of fillet, min	1/2	1/4
L—Overall length, min (Note 4)	8	4
A—Length of reduced section, min	2 1/4	1 1/4
B—Length of grip section, min (Note 5)	2	1 1/4
C—Width of grip section, approximate (Note 2 and Note 6)	3/4	3/8

NOTE 1—The ends of the reduced section shall not differ in width by more than 0.002 in. for the 2.00-in. gage length specimen or 0.001 in. for the 1.00-in. gage length specimen. There may be a gradual taper in width from the ends of the reduced section to the center, but the width at each end shall not be more than 1 % greater than the width at the center.

NOTE 2—For each of the specimens, narrower widths (W and C) may be used when necessary. In such cases the width of the reduced section should be as large as the width of the material being tested permits; however, unless stated specifically, the requirements for elongation in a product specification shall not apply when these narrower specimens are used. If the width of the material is less than W, the sides may be parallel throughout the length of the specimen.

NOTE 3—The dimension T is the thickness of the test specimen as stated in the applicable material specifications. Maximum nominal thicknesses of 1/2-in. and 1/4-in. wide specimens shall be 1/2 in. and 1/4 in., respectively.

NOTE 4—To aid in obtaining axial loading during testing of 1/4-in. wide specimens, the overall length should be as large as the material will permit, up to 8 in.

NOTE 5—It is desirable, if possible, to make the length of the grip section large enough to allow the specimen to extend into the grips a distance equal to two thirds or more of the length of the grips. If the thickness of 1/2-in. wide specimens is over 3/8 in., longer grips and correspondingly longer grip sections of the specimen may be necessary to prevent failure in the grip section.

NOTE 6—The grip-end centerline of the 1/2 -in. wide and 1/4 -in. wide specimens shall coincide with the centerline of the reduced section within 0.01 and 0.005 in., respectively.

FIG. 6 Rectangular Tension Test Specimens

<https://standards.iteh.ai/catalog/standards/sist/148b312a-1d72-4298-8b32-1c3eb8979a38/astm-b557-10>

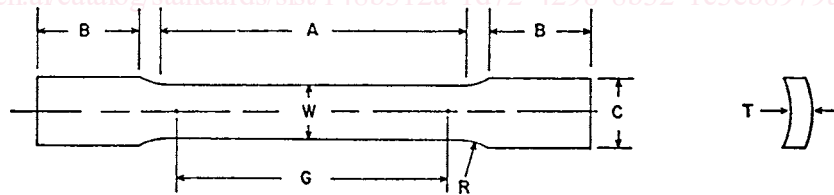

Dimensions, in.

G—Gage length	2.000 ± 0.005
W—Width (Note 1)	0.500 ± 0.010
T—Measured thickness of specimen	Note 2
R—Radius of fillet, min	1/2
A—Length of reduced section, min	2 1/4
B—Length of grip section, min (Note 3)	3
C—Width of grip section, approximate (Note 4)	1 1/16

NOTE 1—The ends of the reduced section shall not differ in width by more than 0.002 in. There may be a gradual taper in width from the ends of the reduced section to the center, but the width at each end shall not be more than 1 % greater than the width at the center.

NOTE 2—The dimension T is the thickness of the tubular section as provided for in the applicable material specifications.

NOTE 3—It is desirable, if possible, to make the length of the grip section great enough to allow the specimen to extend into the grips a distance equal to two thirds or more of the length of the grips.

NOTE 4—The grip-end centerline of the specimen shall coincide with the centerline of the reduced section within 0.05 in.

NOTE 5—For circular segment, the cross-sectional area shall be calculated using the formula shown in 7.2.3

NOTE 6—The radii of all fillets shall be equal to each other within a tolerance of 0.05 in., and the centers of curvature of the two fillets at a particular end shall be located across from each other (on a line perpendicular to the centerline) within a tolerance of 0.10 in.

FIG. 7 Longitudinal Tension Test Specimens for Large-Diameter Tubular Products

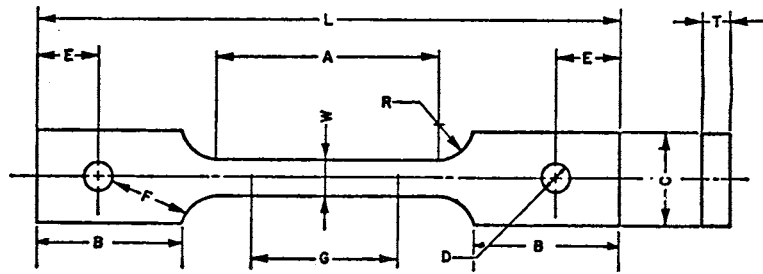

Dimensions, in.

G—Gage length	2.000 ± 0.005
W—Width (Note 1)	0.500 ± 0.010
T—Thickness, max (Note 2)	5/8
R—Radius of fillet, min (Note 3)	1/2
L—Overall length, min	8
A—Length of reduced section, min	2 1/4
B—Length of grip section, min	2
C—Width of grip section, approximate	2
D—Diameter of hole for pin, min (Note 4)	1/2
E—Edge distance from pin, approximate	1 1/2
F—Distance from hole to fillet, min	1/2

NOTE 1—The ends of the reduced section shall differ in width by not more than 0.002 in. There may be a gradual taper in width from the ends of the reduced section to the center, but the width at each end shall be not more than 1 % greater than the width at the center.

NOTE 2—The dimension *T* is the thickness of the test specimen as stated in the applicable product specifications.

NOTE 3—For some materials, a fillet radius *R* larger than 1/2 in. may be needed.

NOTE 4—Holes must be on centerline of reduced section, within ±0.002 in.

NOTE 5—Variations of dimensions *C*, *D*, *E*, *F*, and *L* may be used that will permit failure within the gage length.

FIG. 8 Pin-Loaded Tension Test Specimen with 2-in. Gage Length

6.1.5 Round specimens shall be the standard 0.500-in. diameter specimen in Fig. 9, except when the dimensions of the product make this impossible. In such cases, small-size specimens proportional to the standard specimen shown in Fig. 9 may be used. Unless otherwise specified in the product specification, the selection of round tension specimens shall be as specified in Table 1. Unless permitted by the product specification, the dimensions of the smallest specimen used shall not be less than the following:

	Wrought	Cast
Diameter of reduced section, in.	0.160	0.250
Length of reduced section, in.	3/4	1 1/4
Radius of fillet, in.	1/8	3/16
Diameter of end section, in.	1 5/64	3/8
Overall length, in.		
With shouldered ends	1 1/2	2 3/8
With threaded ends	2	3
With plain cylindrical ends	3	4

6.1.5.1 The shape of the ends of the specimens outside of the gage length shall be suitable to the material and of a shape to fit the holders or grips of the testing machine so that the loads are applied axially. Fig. 10 shows specimens with various types of ends that have given satisfactory results.

6.1.6 Special care is required in the manufacture and testing of smaller specimens because the effects of machining (for example, the amount of end load applied and the amount of heat generated) and testing (for example, eccentricity and gage marking) variables are greater upon them than upon larger specimens. Therefore, the largest practical specimen shall always be used. With some types of materials, notably castings, the result of tests of small specimens may be more variable due to the increasing significance of variations in metallic structure or the character of the surfaces. Low values derived from small specimens should be carefully evaluated in accordance with 8.1 to be certain that the results are valid.

6.1.7 While tensile strengths and yield strengths can properly be compared with results derived from test specimens of various dimensions, elongation values may vary with specimen size and type. Therefore, elongation values should be obtained with specimens of the type from which the published tensile properties were established.

6.2 *Type, Direction, and Location in Wrought Products*—This paragraph and subparagraphs provide the standard requirements for the testing of wrought products for the purpose of quality control and lot release testing. Additions or exceptions to these requirements may need to be made in individual specifications for a particular material or product

NOTE 5—These requirements also do not preclude the use of these test methods for purposes other than quality control as desired for research, material evaluation, or other purpose utilizing other test locations, test directions, and test specimen sizes. In these cases, the general requirements in 6.1 should be followed for specimen type and the requirements in Sections 5 and 7 shall be followed for test apparatus, testing, and analysis.

### 6.2.1 Sheet and Plate:

6.2.1.1 Tension test specimens for non-heat-treatable aluminum alloy sheet and plate shall be taken so that the specimen axis