



Designation: ~~D2559-09~~ Designation: D2559 – 10

Standard Specification for Adhesives for Structural Laminated Wood Products for Use Under Exterior (Wet Use) Exposure Conditions¹

This standard is issued under the fixed designation D2559; the number immediately following the designation indicates the year of original adoption or, in the case of revision, the year of last revision. A number in parentheses indicates the year of last reapproval. A superscript epsilon (ϵ) indicates an editorial change since the last revision or reapproval.

This standard has been approved for use by agencies of the Department of Defense.

INTRODUCTION

This specification, which was initially approved in 1966, was developed to ensure that adhesives developed and used in structural glued laminated timber (glulam) are considered suitable for the intended application. This would include, as a maximum level of severity in the case of moisture effects, full and continuous exposure to the weather in a salt water marine environment.

The use of adhesives for structural wood products (that is, Engineered Wood Products) has expanded beyond Glulam to include products such as Structural Composite Lumber, wood I-Joists and various composites adhesively bonded using a variety of materials. Although most structural glued wood products have traditionally specified an adhesive suitable for exterior exposure, the actual exposure of glued wood products to exterior conditions may range from exposure to the weather for brief periods of time, to continuous exposure to a marine environment. The wide range of possible exterior exposures of the adhesively bonded structural wood product requires consideration of differing performance requirements for the adhesive.

A distinction between adhesive certification and product performance requirements is necessary to ensure the broadest possible acceptance of adhesive systems to the engineered wood products industry. The suitability of adhesive systems for use in the manufacture of engineered wood products for exterior applications is dependent on both the adhesive certification test requirements specified in Specification D2559, and performance requirements provided in specific product standards.

1. Scope

1.1 This specification covers adhesives suitable for the bonding of wood, including treated wood, into structural laminated wood products for general construction, for marine use, or for other uses where a high-strength, waterproof adhesive bond is required.

1.2 The requirements of the adhesive are based on the performance of the adhesive in laminated wood as measured by:

1.2.1 Resistance to shear by compression loading,

1.2.2 Resistance to delamination during accelerated exposure to wetting and drying, and

1.2.3 Resistance to deformation under static load.

1.3 The values stated in SI units are to be regarded as the standard. The values in parentheses are for information only.

1.4 *This standard does not purport to address all of the safety concerns, if any, associated with its use. It is the responsibility of the user of this standard to establish appropriate safety and health practices and determine the applicability of regulatory limitations prior to use.*

2. Referenced Documents

2.1 *ASTM Standards:*²

D9 [Terminology Relating to Wood and Wood-Based Products](#)

D143 [Test Methods for Small Clear Specimens of Timber](#)

D905 [Test Method for Strength Properties of Adhesive Bonds in Shear by Compression Loading](#)

D907 [Terminology of Adhesives](#)

¹ This specification is under the jurisdiction of ASTM Committee D14 on Adhesives and is the direct responsibility of Subcommittee D14.30 on Wood Adhesives. Current edition approved Nov. 1, 2009; 2010. Published February August 2010. Originally approved in 1966. Last previous edition approved in 2004 as D2559 – 04 ϵ . DOI: 10.1520/D2559-10 ϵ .

² For referenced ASTM standards, visit the ASTM website, www.astm.org, or contact ASTM Customer Service at service@astm.org. For *Annual Book of ASTM Standards* volume information, refer to the standard's Document Summary page on the ASTM website.

- D1165 Nomenclature of Commercial Hardwoods and Softwoods
- D1583 Test Method for Hydrogen Ion Concentration of Dry Adhesive Films
- D2555 Practice for Establishing Clear Wood Strength Values
- [D3434 Test Method for Multiple-Cycle Accelerated Aging Test \(Automatic Boil Test\) for Exterior Wet Use Wood Adhesives](#)
- D3535 Test Method for Resistance to Creep Under Static Loading for Structural Wood Laminating Adhesives Used Under Exterior Exposure Conditions
- D4442 Test Methods for Direct Moisture Content Measurement of Wood and Wood-Base Materials
- D4300 Test Methods for Ability of Adhesive Films to Support or Resist the Growth of Fungi
- [D5055 Specification for Establishing and Monitoring Structural Capacities of Prefabricated Wood I-Joists](#)
- D5266 Practice for Estimating the Percentage of Wood Failure in Adhesive Bonded Joints
- [D5456 Specification for Evaluation of Structural Composite Lumber Products](#)
- E6 Terminology Relating to Methods of Mechanical Testing
- E41 Terminology Relating To Conditioning
- E691 Practice for Conducting an Interlaboratory Study to Determine the Precision of a Test Method

3. Terminology

3.1 *Definitions*—Many terms in this specification are defined in Terminology D907.

3.2 *Definitions of Terms Specific to This Standard:*

3.2.1 *delamination, n*—the separation of layers in a laminate because of failure of the adhesive, either in the adhesive itself or at the interface between the adhesive and the adherend.

3.2.2 *glulam, n*—synonym for *structural-glued-laminated timber*.

NOTE 1—The following ASTM standards may be referred to for other terms used in this specification: Nomenclature D1165, Terminologies D9, E6, and E41.

3.2.3 *laminated wood product, n*—a fabricated wood assembly resulting from the bonding together of two or more laminations, all with the direction of grain essentially parallel, to form a larger piece such as a structural member.

3.2.3.1 *Discussion*—The individual laminations themselves may be made up of two or more pieces both in width and length.

3.2.4 *structural-glued-laminated timber, n*—an engineered stress-rated product of a timber laminating plant comprising assemblies of specially selected and prepared wood laminations securely bonded together with adhesives, with the following characteristics: (1) the grain of all laminations is approximately parallel longitudinally; and (2) the laminations may be comprised of pieces end-joined to form any length, of pieces placed or glued edge-to-edge to make wider ones or of pieces bent to curved form during gluing. (Synonym: *glulam*) ANSI/AITC A190.1–1992. American National Standard for Wood Products—Structural Glued Laminated Timber (edited to conform with ASTM format).

4. Significance and Use

[ASTM D2559-10](#)

4.1 Structural design based on strength of material principles of the structural components, including the adhesive and the adhesive's potential durability, requires that the suitability for structural wet use exposure be predicted.

4.2 Performance of the adhesive for resistance to shear by compression loading, resistance to delamination during accelerated aging exposure to wetting and drying, and resistance to deformation under load data developed by this test aid in determining if the adhesive is suitable for structural wet use.

5. Classification

5.1 The manufacturer shall classify the adhesive as to general type. Typical classifications include: resorcinol, phenol-resorcinol, phenol, melamine, etc.

5.2 The manufacturer may be considered to be the testing facility certifying the adhesive.

6. Ordering Information

6.1 The manufacturer will furnish the adhesive in any suitable form agreeable to the purchaser.

7. Fillers and Extenders

7.1 If amylaceous or protein fillers and extenders are used, the adhesive must not only pass requirements of this specification, but in addition, possess sufficient antifungal properties to inhibit the growth of selected fungal species when tested in accordance with Test Method D4300. The adhesive manufacturer shall state in his bulletin whether such materials are present.

8. Chemical Requirements

8.1 The cured adhesive film shall develop a pH value of not less than 2.5 when tested in accordance with Test Method D1583.

9. Physical Requirements

9.1 The adhesive manufacturer shall furnish written instructions stating the general chemical type of adhesive, its storage and mixing procedure, the method of wood preparation, and any other data which is pertinent to the use of the adhesive in the manufacture of laminated wood products.

9.2 The adhesive must pass the tests required by this specification for all limiting conditions recommended in the manufacturer’s bulletin. The information furnished by the manufacturer should include each of the following for each species of wood included in his recommendations:

- 9.2.1 Limits of working life,
- 9.2.2 Minimum and maximum open and closed assembly times as dictated by temperature, moisture content of the wood, mix age, etc.,
- 9.2.3 Minimum spread rates for assembly times and use conditions as indicated in 9.2.2,
- 9.2.4 Minimum cure time and temperature of bondline for complete cure,
- 9.2.5 Minimum pressure, and
- 9.2.6 Maximum and minimum allowable moisture content of the wood.

10. Selection and Preparation of Wood for Testing of Adhesives

10.1 Test the adhesive on the species of wood to be bonded or for which it is recommended including chemically treated wood (see Note 2). The wood shall have a maximum slope of grain of 1 in 15 on any face or any edge. The wood shall contain no knots larger than 3 mm (1/8 in.) in diameter and shall be free from decay, machining defects (such as chipped grain, dubbed ends, feed roll polish, coarse knife marks, and feed roll compression), and any drying defects such as case hardening, collapse, splits, or checks. Use only flat-grained wood.

NOTE 2—Grouping of species is not permitted.

10.2 Wood Moisture Content:

10.2.1 *Ambient Curing Adhesives*—Condition the wood at $23 \pm 2^\circ\text{C}$ ($73.4 \pm 3.6^\circ\text{F}$) and a relative humidity of 50 to 70 % (preferably 65 %) until a moisture content of 8 to 14 % or, preferably 9 to 12 %, has been attained.

10.2.2 *Hot Press Curing Adhesives*—Condition the wood at $23 \pm 2^\circ\text{C}$ ($73.4 \pm 3.6^\circ\text{F}$) and a relative humidity of less than 50 % until a moisture content of 3 to 8 % has been attained.

10.3 Freshly surface each lamination before bonding with the adhesive to be tested. Remove at least 0.4 mm (1/64 in.) from each face within 24 h of bonding. The machining tolerances for each lamination used in preparing the test samples shall be no greater than ± 0.25 mm (0.01 in.) between laminations and ± 0.20 mm (0.008 in.) within laminations.

11. Preparation of Laminated Wood Test Members

11.1 Ambient-Curing Adhesives:

11.1.1 Prepare six pieces of wood of the same species for each laminated wood member. Each of the six pieces shall have a specific gravity equal to or exceeding the minimum requirement of Table 1. Each piece of wood shall be 19-mm (0.75-in.) thick lumber (see Note 3) at least 140 mm (5 1/2 in.) in width and 1 m (40 in.) long. Orient the direction of the annular growth rings when viewed on the end of the laminations in the laminated wood test member so that they are alternated.

TABLE 1 Required Shear Strength for Structural Laminated Wood Products

NOTE 1—For species other than those given, strength values shall be based on 90 % of the value for shear parallel to grain at 12 % moisture content. The use of 90 % of shear parallel to grain at 12 % moisture content takes into account the various subspecies of a particular wood species. The values for shear parallel to grain may be found in Tables 4-3a through 4-4b of the Wood Handbook, Forest Products Society (1999 edition). Base the minimum allowable specific gravity on volume for wood at 12 % moisture content. For species not listed see Note 3. Adjustments for changes in moisture content shall be made in accordance with formula 4-3 (page 4-34) found in the 1999 Wood Handbook.

NOTE 2—It has been documented that bonded shear specimens (Test Method D905 type specimen) on the average provide higher shear strength values than solid wood specimens (Test Methods D143 type specimen). It may appear to be inconsistent to compare shear strength data of bonded specimens to data based on 90 % of the solid wood shear strength found in the Wood Handbook. However, the goal of evaluating shear strength of adhesives in Specification D2559 is to demonstrate the shear strength in a laminated product (tested using Test Method D905 type specimens) meets or exceeds the strength of a solid wood beam when tested by standard procedures for solid wood (Test Methods D143 type specimen).

NOTE 3—For species not found in the 1999 Wood Handbook, values for shear parallel to grain at 12 % moisture content using solid wood are to be obtained on clear, straight-grained specimens following specific ASTM test methods and procedures. These include Test Methods D143 and D2555. Test Methods D143 testing is to be performed on a minimum of 28 shear strength specimens.

Species	Required Shear Strength, KPa (psi) ^A			Minimum Allowable Specific Gravity of Solid Wood Used for Each Lamination ^B
	Moisture Content of Wood at Test			
	8 %	12 %	16 %	
Douglas fir	7 600 (1 110)	7 000 (1 020)	6 500 (940)	0.43
Hemlock, western	8 900 (1 290)	8 000 (1 160)	7 200 (1 050)	0.41
Larch, western	9 400 (1 370)	8 400 (1 220)	7 600 (1 100)	0.55
Oak, white	14 300 (2 080)	12 400 (1 800)	11 000 (1 560)	0.68
Pine, southern	10 400 (1 510)	8 600 (1 250)	7 100 (1 040)	0.51
Redwood	6 300 (910)	5 800 (850)	5 400 (790)	0.40

^A Based on 90 % of the shear strength parallel to grain at 12 % moisture content from Table 4-3 of the 1999 Wood Handbook. Use the same shear strength values for a specific species when chemically treated wood is used.

^B Based on weight when oven dry and volume at 12 % moisture content.

NOTE 3—This thickness would normally come from “nominal 1-in. lumber.”

11.1.1.1 As an alternative to the preparation of laminated wood test members 1 m (40 in.) in length, prepare duplicate 610-mm (24-in.) laminated wood members to obtain at least an equivalent number of test specimens. This alternative includes the preparation of separate two-ply assemblies for evaluation using Test Method D905 block shear specimens that may be used as an alternate to stair-step specimens.

11.1.2 Apply the adhesive uniformly to the contacting faces of each lamination in accordance with the manufacturer’s instructions.

11.1.3 Place the laminated wood members under pressure for a period of time and at the bondline temperature specified by the manufacturer of the adhesive.

11.1.4 *Conditioning*—Condition the laminated wood members at $23 \pm 2^\circ\text{C}$ ($73.4 \pm 3.6^\circ\text{F}$) and a relative humidity of 50 to 70 % (preferably 65 %) for the minimum time recommended by the manufacturer for each curing temperature used during the pressure period, and test immediately.

11.2 *Hot-Press Curing Adhesives* :

11.2.1 Prepare six pieces of wood of the same species for each laminated test member. Each of the six pieces shall have a specific gravity equal to or exceeding the minimum requirement of Table 1. Each piece of wood shall be 19 mm (0.75 in.) thick lumber (see Note 4) at least 140 mm (5½ in.) in width and 1 m (40 in.) long as allowed in 11.1.1.1. Orient the direction of the annular growth rings when viewed on the end of the laminations in the laminated wood test member so that they are alternated.

NOTE 4—This thickness would normally come from “nominal 1 in. lumber.”

11.2.1.1 As an alternative to the preparation of laminated wood test members 1 m (40 in.) in length, prepare duplicate 610-mm (24-in.) laminated wood members to obtain at least an equivalent number of test specimens. This alternative includes the preparation of separate two-ply assemblies for evaluation using Test Method D905 block shear specimens that may be used as an alternate to stair-step specimens.

11.2.2 Apply the adhesive uniformly to the contacting faces of each lamination in accordance with the manufacturer’s instructions.

11.2.3 Hot press three-layer assemblies at the pressure, press temperature, and to the bondline temperature specified by the manufacturer of the adhesive. These three-layer assemblies, after conditioning in accordance with 11.1.4, are assembled into six laminated wood test members using a Specification D2559 approved ambient-curing adhesive for the center bondline in accordance with 11.1.3.

11.2.4 *Conditioning*—Condition the laminated wood members at $23 \pm 2^\circ\text{C}$ ($73.4 \pm 3.6^\circ\text{F}$) and a relative humidity of 50 to 70 % (preferably 65 %) for the minimum time recommended by the manufacturer for each curing temperature used during the pressure period, and test immediately.

12. Number of Tests

12.1 Prepare six laminate wood members for tests, one at each of the limiting conditions listed, but all other factors, as itemized in 9.1 and 9.2, shall be in accordance with the manufacturer’s instructions.

12.1.1 Liquid adhesives:

12.1.1.1 Minimum open assembly time with minimum closed assembly time,

12.1.1.2 Maximum open assembly time with maximum closed assembly time, and

12.1.1.3 Minimum open assembly time with maximum closed assembly time.

12.1.2 Film adhesives:

12.1.2.1 Minimum cure time,

12.1.2.2 Minimum cure temperature, and

12.1.2.3 Minimum pressure.

13. Preparation of Test Specimens

13.1 Dress the laminated wood members, prepared in accordance with Sections 11 and 12, on the sides to a uniform width of 127 mm (5 in.) at the completion of the conditioning period. Trim 76 mm (3 in.) off one end of each of these members and discard it. Cut the remaining trimmed members into five sections as shown in Fig. 1. Use the 102-mm (4-in.) sections labeled “A” for conducting tests in resistance to shear by compression loading in accordance with Section 14, and use the 254-mm (10-in.) sections labeled “B” for conducting resistance to delamination tests in accordance with Section 15. Discard the remaining waste trim portion.

13.1.1 If duplicate laminated wood members are made in accordance with 11.1.1.1 or 11.2.1.1 to obtain at least an equivalent number of test specimens, then trim 51 mm (2 in.) off each end. Utilize the remaining trimmed member, 508 mm (20 in.) in length by cutting two 254-mm (10-in.) sections labeled “B” or one 254-mm section “B” and two 102-mm (4-in.) sections “A” as shown in Fig. 1. If two “B” sections are prepared then make separate specimens for shear testing by preparing two-layer laminated wood members and specimens in accordance with Test Method D905 and 11.1.1.1 and 11.2.1.1. Make and test these specimens from the same species of wood, at exactly the same time, and under the same conditions as required for other test samples in this specification.

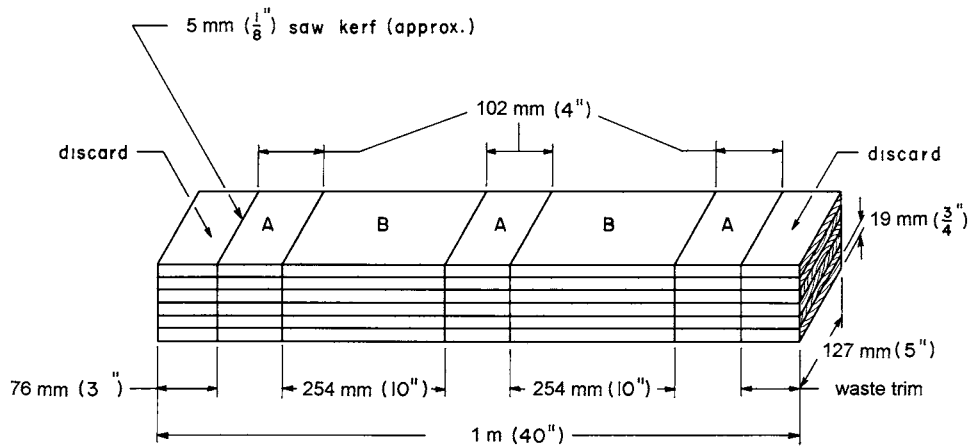

FIG. 1 Laminated Test Beam

TEST METHODS — ADHESIVE SERVICE CLASS A

14. Resistance to Shear by Compression Loading

14.1 *Apparatus*—The testing machine capacity is to be of about 66900 N (15 000 lb) in compression or of sufficient capacity to test the species of wood in use. Equip the testing machine with a shearing tool containing a self-aligning seat to ensure uniform lateral distribution of the load. The machine shall be capable of maintaining a uniform rate of loading such that the load is applied with a continuous motion of the movable head to a maximum rate load not to exceed 13-mm (0.50-in.)/min. The shearing tool shown in Fig. 1 of Test Method D905 has been found satisfactory. Locate the testing machine in an atmosphere such that the moisture content of the test pieces developed in accordance with 11.1.4 is not noticeably altered during testing.

14.2 *Samples:*

14.2.1 Prepare at least six samples for testing in shear by compression loading. When stair-step shear samples are used, cut two from each of the 102-mm (4-in.) sections labeled “A” in Fig. 1. When separate two-ply laminated wood samples are made in accordance with 11.1.1.1 or 11.2.1.1 make at least six test samples and cut at least five test specimens from each as specified by the dimensions of Figs. 2 and 3 of Test Method D905.

14.2.2 The stair-step shear specimens shall conform to the form and dimensions shown in Fig. 2. Take care in preparing the test specimens to assure that the grain direction in the wood is parallel to the direction of loading during test. The loaded surfaces shall be smooth and parallel to each other and perpendicular to the height. When sawing the bonded assembly, exercise care to ensure that the saw cuts to, but not beyond, the adhesive line. Measure the width and height of the specimen at the adhesive line to the nearest 0.25 mm (0.01 in.) to determine the shear area. All requirements above shall apply when individual test specimens are cut from the separately laminated test members of Test Method D905.

14.2.3 Condition the individual test specimens in the conditioning environment described in 11.1.4 and 11.2.4 to a target moisture content of 8, 12, or 16 % for species listed in Table 1. For all other species condition to a target moisture content of 12 %. The allowable variation in the target moisture content before testing is ± 1 %. Moisture content is to be determined using Test Methods D4442.

14.3 Test the test specimens cut from the test samples described in 14.2 to failure. Report the shear strength calculated in kilopascals (kPa) (pounds per square inch (psi)) based on the bonded area between two laminations rounded to the nearest 0.0645 mm² (0.01 in.²), for each test specimen together with the estimated percentage wood failure. Practice D5266 has been found useful in estimating the percentage of wood failure in adhesive bonded joints.

14.4 *Requirements:*

14.4.1 The average shear strength for each group of laminated wood members made at one manufacturing condition as specified in Section 12, and tested as described above shall be not less than the values specified in Table 1 at the appropriate moisture content of the wood.

14.4.2 The average wood failure for each group of laminated wood members made at one condition and tested as prescribed in Section 14 shall be not less than 75 % for all species listed in Table 1.

14.5 *Retest:*

14.5.1 If the strength requirements of 14.4 are not satisfied, but the wood failure value is 95 % or more, retest the adhesive.

15. Resistance to Delamination During Accelerated Exposure

15.1 *Apparatus:*

15.1.1 An autoclave or similar pressure vessel capable of withstanding at least 550 kPa (80 psi) is required for impregnating the specimens with water. Equip the vessel with a vacuum pump or similar device capable of drawing vacuum of at least 85 kPa (25 in.) Hg (sea level) in the vessel and provide a method for obtaining pressures to 517 kPa (75 psig). Equip the vessel with a steam inlet capable of providing steam at 100°C (212°F) for 1½ h.

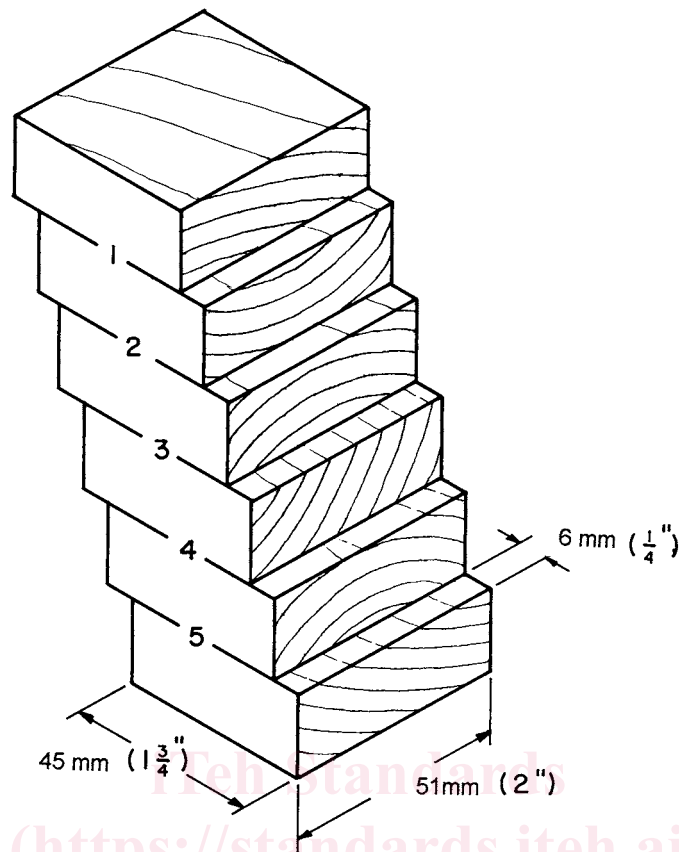

FIG. 2 Stair-Step Shear Specimen

15.1.2 An oven capable of maintaining $65.5 \pm 2^\circ\text{C}$ ($150 \pm 3.6^\circ\text{F}$) with sufficient circulation to remove moisture from the chamber is required for drying the specimens.

15.1.3 Circular fluorescent desk lamp with $5\times$ viewing magnifier in the center of the lamp. Equivalent light sources and magnifier may be substituted for the above.

15.1.4 Machinist's scale graduated in 0.01 and 0.10 divisions.

15.2 *Samples:*

15.2.1 For ambient-curing adhesives prepare six delamination specimens representing three from each 254-mm (10-in.) section labeled "B" in Fig. 1. Cut each 254-mm section into three 76-mm (3-in.) specimens with the 76-mm dimension parallel to the grain direction in the wood. The total length of bondlines on each end grain face is 635 mm (25 in.). On six specimens this equals 7620 mm (300 in.). Test eighteen specimens (six from each of three laminated wood test members prepared in accordance with Sections 11, 12, and 13 to certify each adhesive on each species of wood to be laminated.

15.2.2 For hot-press curing adhesives prepare eight delamination specimens (four from each 610 mm (24 in.) laminated wood member as allowed in 13.1.1) with dimensions as specified in 15.2.1. In order to achieve the required 7620 mm (300 in.) of test bondlines (as specified in 15.2.1) with hot-pressed laminated wood members, the end grain faces of 7.5 specimens are required. Thus for hot-press curing adhesives, four test bondlines 508 mm (20 in.) on each end grain face of 8 specimens will be examined for a total of 8128 mm (320 in.). Test twenty four specimens (four from each of six laminated wood test members prepared in accordance with Sections 11-13) to certify each adhesive on each species of wood to be laminated.

15.3 *Procedure:*

15.3.1 Weigh and record to the nearest 1 g (0.035 oz) the weight of each test specimen. Place the eighteen 76-mm (3-in.) test specimens in the pressure vessel described in 15.1.1, weigh down, and admit water at a temperature of 18 to 27°C (65 to 80°F) in sufficient quantity so that the specimens are completely submerged throughout the test. Separate the test specimens by stickers, wire screens, or other means in such a manner that all end grain surfaces are freely exposed to the water. Draw a vacuum of at least 85 kPa (25 in.) Hg (sea level) and hold for 5 min. Release the vacuum and apply pressure of 517 ± 14 kPa (75 ± 2 psi) for 1 h. Repeat the vacuum-pressure cycle with the test specimens remaining submerged, making a two-cycle impregnating period requiring a total of approximately $2\frac{1}{2}$ h (Note 5). Dry the test specimens in the oven described in 15.1.2 at $65.5 \pm 2^\circ\text{C}$ ($150 \pm 3.6^\circ\text{F}$) for a period of between 21 and 22 h, with sufficient air circulation to lower their weight to within 15 % of the original test specimen weight. During drying, place the test specimens at least 51 mm (2 in.) apart with the end-grain surfaces parallel to the stream of air. This completes the first cycle.