



Designation: D2168-02a

Standard Test Methods for Designation: D2168 – 10

Standard Practices for Calibration of Laboratory Mechanical-Rammer Soil Compactors¹

This standard is issued under the fixed designation D2168; the number immediately following the designation indicates the year of original adoption or, in the case of revision, the year of last revision. A number in parentheses indicates the year of last reapproval. A superscript epsilon (ϵ) indicates an editorial change since the last revision or reapproval.

This standard has been approved for use by agencies of the Department of Defense.

1. Scope*

1.1 These ~~test methods~~ practices for the calibration of mechanical soil compactors are for use in checking and adjusting mechanical devices used in laboratory compacting of soil and soil-aggregate in accordance with Test Methods D698, D1557, Practice D6026, and other methods of a similar nature ~~which that~~ might specify ~~this method~~ these practices. Calibration for use with one ~~method~~ practice does not qualify the equipment for use with another ~~method~~ practice.

1.2 The weight of the mechanical rammer is adjusted as described in 5.4 and 6.5 in order to provide ~~that~~ for the mechanical compactor ~~will to~~ produce the same result as the manual compactor.

1.3 Two alternative procedures are provided as follows:

		Section
Test Method A	Calibration based on the compaction of a selected soil sample	5
Practice A	Calibration based on the compaction of a selected soil sample	5
Test Method B	Calibration based on the deformation of a standard lead cylinder	6
Practice B	Calibration based on the deformation of a standard lead cylinder	6

1.4 If a mechanical compactor is calibrated in accordance with the requirements of either ~~Test Method Practice A~~ or ~~Test Method Practice B~~, it is not necessary for ~~the mechanical compactor~~ to meet the requirements of the other ~~method~~ practice.

1.5 The values stated in inch-pound units are to be regarded as the standard. The values given in parentheses are for information only.

1.5.1 It is common practice in the engineering profession to concurrently use pounds to represent both a unit of mass (lbm) and a force (lbf). This implicitly combines two separate systems of units; that is, the absolute system and the gravitational system. It is scientifically undesirable to combine the use of two separate sets of inch-pound units within a single standard. This standard has been written using the gravitational system of units when dealing with the inch-pound system. In this system, the pound (lbf) represents a unit of force (weight). However, the use of balances or scales recording pounds of mass (lbm) or the recording of density in lbm/ft^3 shall not be regarded as a nonconformance with this standard.

1.6 *This standard does not purport to address all of the safety concerns, if any, associated with its use. It is the responsibility of the user of this standard to establish appropriate safety and health practices and determine the applicability of regulatory limitations prior to use.*

2. Referenced Documents

2.1 *ASTM Standards:*²

D653 [Terminology Relating to Soil, Rock, and Contained Fluids](#)

¹ These ~~test methods~~ practices are under the jurisdiction of ASTM Committee D18 on Soil and Rock and are the direct responsibility of Subcommittee D18.03 on Texture, Plasticity and Density Characteristics of Soils.

Current edition approved Nov. 10, 2002. Published January 2003. Originally approved in 1990. Last previous edition D2168-02. DOI: 10.1520/D2168-02A.

Current edition approved July 1, 2010. Published August 2010. Originally approved in 1990. Last previous edition approved in 2002 as D2168-02a. DOI: 10.1520/D2168-10.

² For referenced ASTM standards, visit the ASTM website, www.astm.org, or contact ASTM Customer Service at service@astm.org. For *Annual Book of ASTM Standards* volume information, refer to the standard's Document Summary page on the ASTM website.

*A Summary of Changes section appears at the end of this standard.

- D698 Test Methods for Laboratory Compaction Characteristics of Soil Using Standard Effort (12 400 ft-lbf/ft³(600 kN-m/m³))
- D1557 Test Methods for Laboratory Compaction Characteristics of Soil Using Modified Effort (56,000 ft-lbf/ft³(2,700 kN-m/m³))
- D2487 Practice for Classification of Soils for Engineering Purposes (Unified Soil Classification System)
- D3740 Practice for Minimum Requirements for Agencies Engaged in Testing and/or Inspection of Soil and Rock as Used in Engineering Design and Construction
- D6026 Practice for Using Significant Digits in Geotechnical Data
- E11 Specification for Woven Wire Test Sieve Cloth and Test Sieves
- E145 Specification for Gravity-Convection and Forced-Ventilation Ovens

3. Significance and Use

3.1 Mechanical compactors are commonly used to replace the hand compactors required for Test Methods D698 and D1557 in cases where it is necessary to increase production.

3.2 The design of mechanical compactors is such that it is necessary to have a calibration process that goes beyond determining the mass and drop of the hammer.

NOTE 1—The quality of the result produced by this standard is dependent on the competence of the personnel performing it, and the suitability of the equipment and facilities used. Agencies that meet the criteria in Practice D3740 are generally considered capable of competent and objective testing/sampling/inspection/and the like. Users of this standard are cautioned that compliance with Practice D3740 does not in itself assure reliable results. Reliable results depend on many factors; Practice D3740 provides a means of evaluating some of those factors.

4. Apparatus

4.1 For ~~Test Method~~Practice A, in addition to the apparatus requirements specified in Test Methods D698 and D1557, the following is required:

4.1.1 *Drying Oven*—Thermostatically controlled oven, preferably of the forced-draft type, meeting the requirements for Specification E145 and capable of maintaining a uniform temperature of $140 \pm 5^\circ\text{F}$ ($60 \pm 3^\circ\text{C}$) throughout the drying chamber.

4.2 For ~~Test Method~~Practice B, in addition to the apparatus requirements specified in Test Methods D698 and D1557, the following are required:

4.2.1 *Lead Deformation Apparatus*—A lead deformation apparatus consisting of an anvil, guide collar, and striking pin, as shown in Fig. 1.

4.2.2 *Micrometer*—A ~~1-in. or 25-mm~~ one-inch (25-mm) outside micrometer or caliper reading to 0.001 in. ~~or 0.02 mm, (0.02 mm),~~ for determining the length of the lead cylinders. As an alternative, a one-inch (25-mm) dial comparator of equal accuracy reading to 0.001 in. (0.02 mm) may be used to determine either the length of the lead cylinder, or of the complete lead deformation apparatus assembly. ~~In order to~~ To measure the complete assembly, a dial comparator with a minimum opening of 2 in. (~~51 mm~~) and a travel of 1 in. (~~25~~50 mm) is required (see Fig. 2).

NOTE 2—The use of vernier calipers is not recommended since ~~they~~ the vernier calipers can produce erroneous readings if not zeroed correctly, or if the vernier caliper is not of high quality.

4.2.3 *Guide Sleeve Pedestal*—A guide sleeve pedestal for use with guide sleeves used to control the drop of the manual rammers in Test Methods D698 and D1557 (see Fig. 3).

4.2.4 *Test Cylinders*—A supply of commercially pure lead test cylinders having individual weights such that the lightest cylinder is within 0.06 g of the heaviest, each having a length of 0.675 ± 0.005 in. (17.1 ± 0.1 mm) and a diameter of 0.310 ± 0.002 in. (7.87 ± 0.05 mm).³ A minimum of ten test cylinders is required for the calibration of one mechanical compactor. However, depending on circumstances, as many as 100 test cylinders may be required.

5. Procedure—~~Test Method A~~ Procedure—Practice A

5.1 ~~Thoroughly inspect~~Evaluate the mechanical and manual compactors for evidence of wear, malfunction, and need of servicing and adjustment. Clean, adjust, and lubricate the compactors so as to meet all requirements of the manufacturer, and the applicable method under which they will be used and for which the mechanical compactor is to be calibrated. Operate the compactor for a minimum of 25 drops to cause friction in the parts to become constant, allowing the rammer to fall on soil or other soft material.

NOTE 3—In order to provide satisfactory results, mechanical compactors must be in excellent working condition. Improper operation of the raising and release mechanisms can introduce serious errors.

5.2 Obtain approximately 50 lb (23 kg) of soil classified as CL in accordance with Classification D2487. If excessive moisture is present, dry the soil until it becomes friable. Drying may be in air or by use of a drying apparatus such that the temperature of

² Lead test cylinders are available from the Hornady Manufacturing Co., P.O. Box 1848, Grand Island, Nebr. 68801 in lots of 500.

³ The sole source of supply of the lead test cylinders known to the committee at this time is Hornady Manufacturing Co., P.O. Box 1848, Grand Island, Nebr. 68801 in lots of 500. If you are aware of alternative suppliers, please provide this information to ASTM International Headquarters. Your comments will receive careful consideration at a meeting of the responsible technical committee, which you may attend.

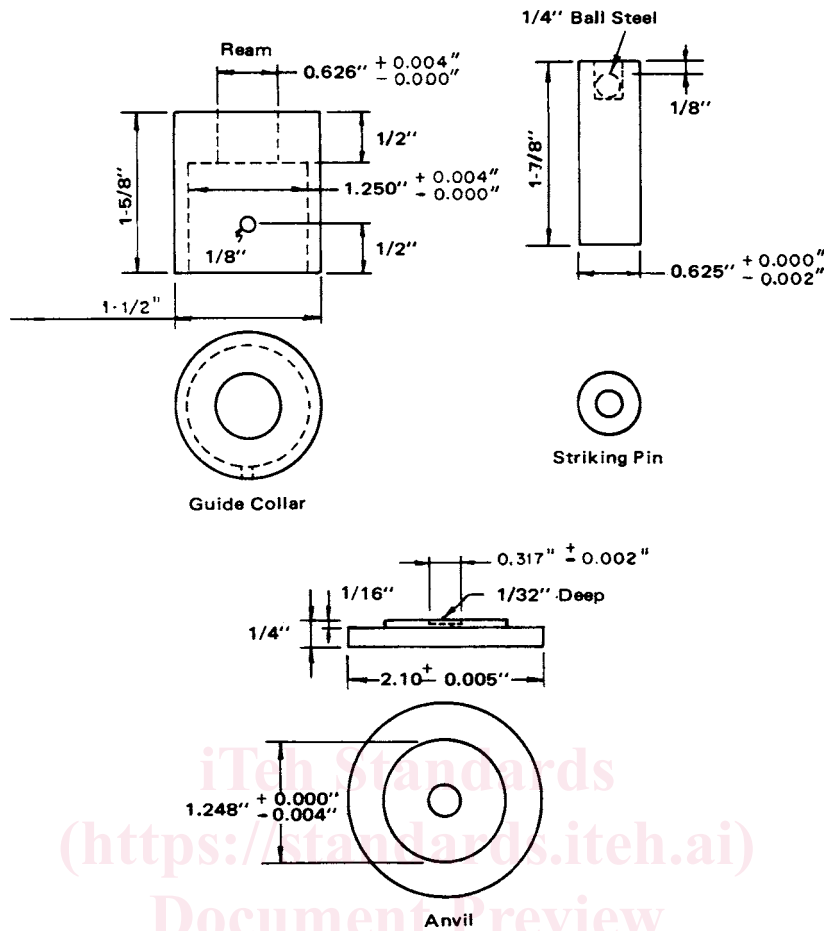

in.	mm
2.10	53.34
1 7/8	48
1 5/8	41
1 1/2	38
1.250	31.75
1.248	31.70
0.626	15.90
0.625	15.88
1/2	13
0.317	8.05
1/4	6.4
1/8	3.2
1/16	1.6
1/32	0.79
0.005	0.13
0.004	0.10
0.002	0.05
0.001	0.02

NOTE 1—Inside dimension of guide collar should slip easily over raised section of anvil without excessive free play. Anvil should slip easily inside guide sleeve pedestal without excessive free play.

FIG. 1 Lead Deformation Apparatus

the sample does not exceed 140°F (60°C). Pass the soil through a No. 4 (4.75-mm) sieve conforming to the requirements of Specification E11. Discard any material remaining on the sieve, and thoroughly blend the material passing the sieve until it is uniform. The material shall then be prepared for compaction in accordance with either Methods D698 or D1557 as appropriate for the mechanical compactor being calibrated.

NOTE 4—The amount of soil used will vary greatly depending on the number of water content unit mass determinations required.

5.3 Using the soil prepared in accordance with 5.2, determine optimum moisture and maximum dry unit weight by Method A of either Test Methods D698 or D1557 or whichever method is appropriate for the mechanical compactor being calibrated. Prepare

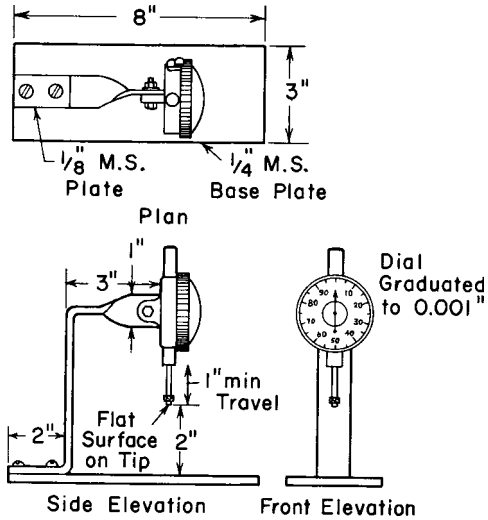

in.	mm
8	203
3	76
2	51
1	25
1/4	6.4
1/8	3.2
0.001	0.02

FIG. 2 Dial Comparator

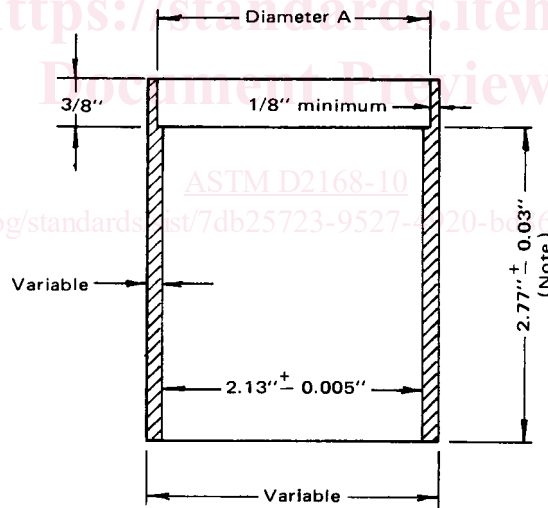

in.	mm
2.77	70.4
2.13	54.10
3/8	10
1/8	3.2
0.03	0.8
0.005	0.13

NOTE 1—This dimension must be equal to the height of the lead deformation apparatus when assembled with the lead cylinder in place, within a tolerance of ± 0.01 in. (± 0.25 mm).

NOTE 2—Diameter A is such that guide sleeve of rammer fits easily into recess without free play.

FIG. 3 Guide Sleeve Pedestal