



Designation: ~~D2171-07~~<sup>ε1</sup>



Designation: ~~222/84 (89)~~ Designation: D2171/D2171M - 10

## Standard Test Method for Viscosity of Asphalts by Vacuum Capillary Viscometer<sup>1</sup>

This standard is issued under the fixed designation D2171/D2171M; the number immediately following the designation indicates the year of original adoption or, in the case of revision, the year of last revision. A number in parentheses indicates the year of last reapproval. A superscript epsilon ( $\epsilon$ ) indicates an editorial change since the last revision or reapproval.

*This standard has been approved for use by agencies of the Department of Defense. ~~e<sup>1</sup>Note—Table X1.1 was editorially corrected in March 2010.~~*

*This test method has been approved by the sponsoring committees and accepted by the cooperating societies in accordance with established procedures.*

### 1. Scope

1.1 This test method covers procedures for the determination of viscosity of asphalt binder (bitumen) by vacuum capillary viscometers at 60°C (140°F) [140°F]. It is applicable to materials having viscosities in the range from 0.0036 to over 20 000 Pa · s (0.036 [0.036 to over 200 000 P]-P].

~~NOTE—This test method is suitable for use at other temperatures, but the precision is based on determinations on asphalt binders at 60°C (140°F).~~

~~1.2 1—This test method is suitable for use at other temperatures, but the precision is based on determinations on asphalt binders at 60°C [140°F].~~

1.2 The values stated in either SI units or inch-pound units are to be regarded separately as standard. The values stated in each system may not be exact equivalents; therefore, each system shall be used independently of the other. Combining values from the two systems may result in non-conformance with the standard.

1.3 **Warning**—Mercury has been designated by the United States Environmental Protection Agency (EPA) and many state agencies as a hazardous material that can cause central nervous system, kidney and liver damage. Mercury, or its vapor, may be hazardous to health and corrosive to materials. Caution should be taken when handling mercury and mercury containing products. See the applicable product Material Safety Data Sheet (MSDS) for details and EPA's website—<http://www.epa.gov/mercury/faq.htm>—for additional information. Users should be aware that selling mercury, mercury-containing products, or both, into your state may be prohibited by state law.

~~1.3~~  
1.4 *This standard does not purport to address all of the safety concerns, if any, associated with its use. It is the responsibility of the user of this standard to establish appropriate safety and health practices and determine the applicability of regulatory limitations prior to use.*

### 2. Referenced Documents

2.1 *ASTM Standards:*<sup>2</sup>

E1 Specification for ASTM Liquid-in-Glass Thermometers

E11 Specification for Woven Wire Test Sieve Cloth and Test Sieves

E77 Test Method for Inspection and Verification of Thermometers

### 3. Terminology

3.1 *Definitions:*

<sup>1</sup> This test method is under the jurisdiction of ASTM Committee D04 on Road and Paving Materials and is the direct responsibility of Subcommittee D04.44 on Rheological Tests. In the IP this test method is under the jurisdiction of the Standardization Committee.

~~Current edition approved Dec. 1, 2007. Published January 2008. Originally approved in 1963. Last previous edition approved in 2001 as D2171-01. DOI: 10.1520/D2171-07.~~

Current edition approved June 1, 2010. Published August 2010. Originally approved in 1963. Last previous edition approved in 2007 as D2171-07 <sup>ε1</sup>. DOI: 10.1520/D2171-10.

<sup>2</sup> For referenced ASTM standards, visit the ASTM website, [www.astm.org](http://www.astm.org), or contact ASTM Customer Service at [service@astm.org](mailto:service@astm.org). For *Annual Book of ASTM Standards* volume information, refer to the standard's Document Summary page on the ASTM website.

3.1.1 *Newtonian liquid*—a liquid in which the rate of shear is proportional to the shearing stress. The constant ratio of the shearing stress to the rate of shear is the viscosity of the liquid. If the ratio is not constant, the liquid is non-Newtonian.

3.1.2 *viscosity*—the ratio between the applied shear stress and rate of shear is called the coefficient of viscosity. This coefficient is thus a measure of the resistance to flow of the liquid. It is commonly called the viscosity of the liquid. The SI unit of viscosity is  $1 \text{ Pa} \cdot \text{s}$  ( $1 \text{ N}\cdot\text{s}/\text{m}^2$ ) and is called a Pascal-second. The cgs unit of viscosity is  $1 \text{ g}/\text{cm}\cdot\text{s}$  ( $1 \text{ dyne}\cdot\text{s}/\text{cm}^2$ ) and is called a poise (P).  $1 \text{ Pa} \cdot \text{s}$  is equivalent to 10 P.

#### 4. Summary of Test Method

4.1 The time is measured for a fixed volume of the liquid to be drawn up through a capillary tube by means of vacuum, under closely controlled conditions of vacuum and temperature. The viscosity in Pascal-seconds is calculated by multiplying the flow time in seconds by the viscometer calibration factor.

NOTE 2—The rate of shear decreases as the liquid moves up the tube, or it can also be varied by the use of different vacuum or different size viscometers. Thus, this method is suitable for the measurement of viscosities of Newtonian (simple) and non-Newtonian (complex) liquids.

#### 5. Significance and Use

5.1 The viscosity at  $60^\circ\text{C}$  ( $140^\circ\text{F}$ )[ $140^\circ\text{F}$ ] characterizes flow behavior and may be used for specification requirements for cutbacks and asphalt binders.

#### 6. Apparatus

6.1 *Viscometers*, capillary-type, made of borosilicate glass, annealed, suitable for this test are as follows:

6.1.1 *Cannon-Manning Vacuum Viscometer* (CMVV), as described in Appendix X1.

6.1.2 *Asphalt Institute Vacuum Viscometer* (AIVV), as described in Appendix X2.

6.1.3 *Modified Koppers Vacuum Viscometer* (MKVV), as described in Appendix X3.

6.1.4 Calibrated viscometers are available from commercial suppliers. Details regarding calibration of viscometers are given in Appendix X4.

NOTE 3—The viscosity measured in a CMVV may be from 1 to 5 % lower than either the AIVV or MKVV having the same viscosity range. This difference, when encountered, may be the result of non-Newtonian flow.<sup>3</sup>

6.2 *Thermometers*—Calibrated liquid-in-glass thermometers (see Table X5.1) of an accuracy after correction of  $0.02^\circ\text{C}$  ( $0.04^\circ\text{F}$ )[ $0.04^\circ\text{F}$ ] can be used or any other thermometric device of equal accuracy. ASTM Kinematic Viscosity Thermometers 47C and 47F conforming to Specification E1 are suitable for the most commonly used temperature of  $60^\circ\text{C}$  ( $140^\circ\text{F}$ )[ $140^\circ\text{F}$ ].

6.2.1 The specified thermometers are standardized at “total immersion,” which means immersion to the top of the mercury liquid column with the remainder of the stem and the expansion chamber at the top of the thermometer exposed to room temperature. The practice of completely submerging the thermometer is not recommended. When thermometers are completely submerged, corrections for each individual thermometer based on calibration under conditions of complete submergence must be determined and applied. If the thermometer is completely submerged in the bath during use, the pressure of the gas in the expansion chamber will be higher or lower than during standardization, and may cause high or low readings on the thermometer. Thermometric devices for this test method must be standardized at least every 6 months.

6.2.2 It is essential that liquid-in-glass thermometers be calibrated periodically using the technique given in Test Method E77 (see Appendix X5).

6.3 *Bath*—A bath suitable for immersion of the viscometer so that the liquid reservoir or the top of the capillary, whichever is uppermost, is at least 20 mm below the upper surface of the bath liquid and with provisions for visibility of the viscometer and the thermometer. Firm supports for the viscometer shall be provided. The efficiency of the stirring and the balance between heat losses and heat input must be such that the temperature of the bath medium does not vary by more than  $\pm 0.03^\circ\text{C}$  ( $\pm 0.05^\circ\text{F}$ )[ $\pm 0.05^\circ\text{F}$ ] over the length of the viscometer, or from viscometer to viscometer in the various bath positions.

6.4 *Vacuum System*—A vacuum system<sup>4</sup> capable of maintaining a vacuum to within  $\pm 0.5$  mm of the desired level up to and including 40.0 kPa ( $300$ [ $300$  mm Hg]-Hg]. The essential system is shown schematically in Fig. 1. Tubing of 6.35-mm ( $1/4$ -in.)-in. inside diameter should be used, and all joints should be airtight so that when the system is closed, no loss of vacuum is indicated by the pressure gauge. A vacuum or aspirator pump is suitable for the vacuum source. The vacuum measuring system for this test method must be standardized at least once a year.

6.5 *Timer*—A stop watch or other timing device graduated in divisions of 0.1 s or less and accurate to within 0.05 % when tested over intervals of not less than 15 min. Timing devices for this test method must be calibrated at least every 6 months.

6.5.1 *Electrical Timing Devices* may be used only on electrical circuits, the frequencies of which are controlled to an accuracy of 0.05 % or better.

6.5.1.1 Alternating currents, the frequencies of which are intermittently and not continuously controlled, as provided by some public power systems, can cause large errors, particularly over short timing intervals, when used to actuate electrical timing devices.

<sup>3</sup> Supporting data have been filed at ASTM International Headquarters and may be obtained by requesting Research Report RR:D04-1003.

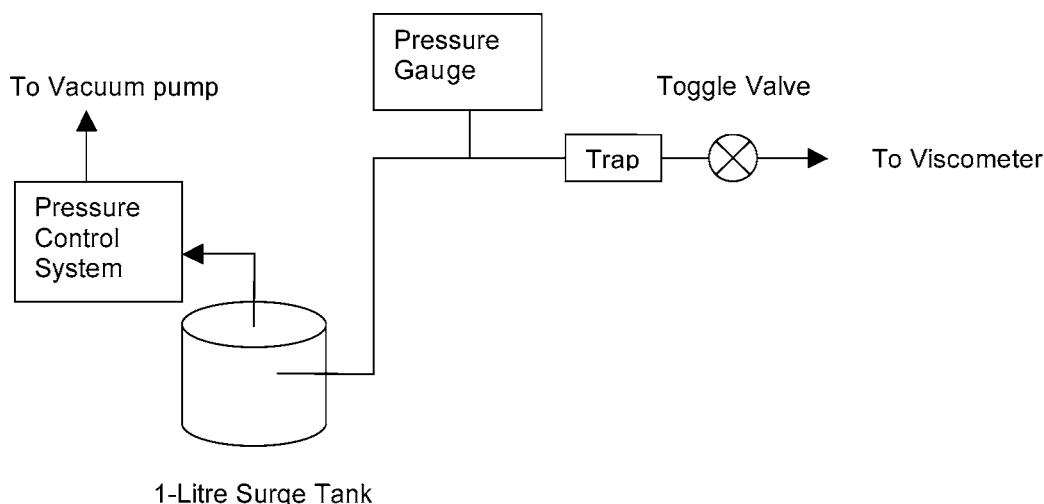

FIG. 1 Suggested Vacuum System for Vacuum Capillary Viscometers

## 7. Sample Preparations

7.1 Heat the sample with care to prevent local overheating until it has become sufficiently fluid to pour, occasionally stirring the sample to aid heat transfer and to assure uniformity.

7.2 Transfer a minimum of 20 mL into a suitable container and heat to  $135 \pm 5.5^\circ\text{C}$  ( $275 \pm 10^\circ\text{F}$ ), stirring occasionally to prevent local overheating and taking care to avoid the entrapment of air.

NOTE 4—If it is suspected that the sample may contain solid material, strain the melted sample into the container through a No. 50 (300- $\mu\text{m}$ ) 300- $\mu\text{m}$  [No. 50] sieve conforming to Specification E11.

NOTE 5—In the case of very viscous or modified asphalts, it may be necessary to heat in an oven at  $163 \pm 5^\circ\text{C}$  [ $325 \pm 10^\circ\text{F}$ ] in order for the material to become sufficiently fluid to stir and pour.

## 8. Procedure

8.1 The specific details of operation vary somewhat for the various types of viscometers. See the detailed descriptions of viscometers in Appendix X1-Appendix X3 for instructions for using the type of viscometer selected. In all cases, however, follow the general procedure described in 8.1.1-8.1.9.

8.1.1 Maintain the bath at the test temperature within  $\pm 0.03^\circ\text{C}$  ( $\pm 0.05^\circ\text{F}$ ). Apply the necessary corrections, if any, to all thermometer readings.

8.1.2 Select a clean, dry viscometer that will give a flow time greater than 60 s, and preheat to  $135 \pm 5.5^\circ\text{C}$  ( $275 \pm 10^\circ\text{F}$ ).

8.1.3 Charge the viscometer by pouring the prepared sample to within  $\pm 2$  mm of fill line E (Fig. 2, Fig. 3, and Fig. 4).

8.1.4 Place the charged viscometer in an oven or bath maintained at  $135 \pm 5.5^\circ\text{C}$  ( $275 \pm 10^\circ\text{F}$ ) for a period of  $10 \pm 2$  min, to allow large air bubbles to escape.

8.1.5 Remove the viscometer from the oven or bath and, within 5 min, insert the viscometer in a holder, and position the viscometer vertically in the bath so that the upper most timing mark is at least 20 mm below the surface of the bath liquid.

8.1.6 Establish a  $40.0 \pm 0.07$  kPa ( $300 \pm 0.5$  mm Hg) vacuum below atmospheric pressure in the vacuum system and connect the vacuum system to the viscometer with the toggle valve or stopcock closed in the line leading to the viscometer.

8.1.7 After the viscometer has been in the bath for  $30 \pm 5$  min, start the flow of asphalt in the viscometer by opening the toggle valve or stopcock in the line leading to the vacuum system.

8.1.8 Measure to within 0.1 s the time required for the leading edge of the meniscus to pass between successive pairs of timing marks. Report the first flow time which exceeds 60 s between a pair of timing marks, noting the identification of the pair of timing marks.

8.1.9 Upon completion of the test, clean the viscometer thoroughly by several rinsings with an appropriate solvent completely miscible with the sample, followed by a completely volatile solvent. Dry the tube by passing a slow stream of filtered dry air through the capillary for 2 min, or until the last trace of solvent is removed. Alternatively, the viscometer may be cleaned in a glass-cleaning oven, at a temperature not to exceed  $500^\circ\text{C}$  ( $932^\circ\text{F}$ ), followed by rinses with distilled or deionized water, residue-free acetone, and filtered dry air. Periodically, if deposits are observed, clean the instrument with a strong acid cleaning solution to remove organic deposits, rinse thoroughly with distilled or deionized water and residue-free acetone, and dry with filtered dry air.

8.1.9.1 Chromic acid cleaning solution may be prepared by adding, with the usual precautions, 800 mL of concentrated sulphuric acid to a solution of 92 g of sodium dichromate in 458 mL of water. The use of similar commercially available sulphuric acid cleaning solutions is acceptable. Nonchromium-containing, strongly oxidizing acid cleaning solutions may be substituted so

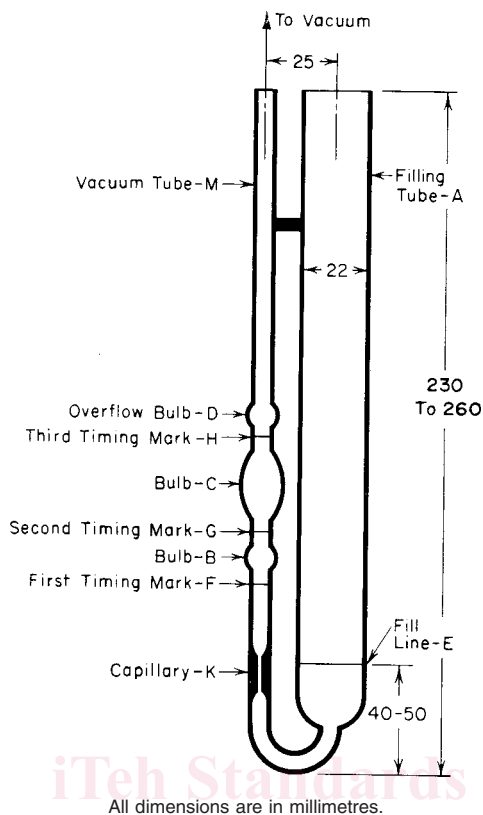

FIG. 2 Cannon-Manning Vacuum Capillary Viscometer

as to avoid the disposal problems of chromium-containing solutions.

8.1.9.2 Use of alkaline glass cleaning solutions may result in a change of viscometer calibration, and is not recommended.

## 9. Calculation

9.1 Select the calibration factor that corresponds to the pair of timing marks used for the determination, as prescribed in 8.1.8. Calculate and report the viscosity to three significant figures using the following equation:

$$\text{Viscosity, } Pa \cdot s = (Kt) \quad (1)$$

where:

$K$  = selected calibration factor,  $Pa \cdot s/s$ , and

$t$  = flow time, s.

NOTE 5—If 6—If the viscometer constant or calibration factor ( $K_{cgs}$ ) is known in cgs units (Poise/s) calculate the calibration factor ( $K_{si}$ ) in SI units (pascal-seconds/second) as follows:

$$K_{si} = (Pa \cdot s/s) = K_{cgs}/10 \text{ or } (P/s)/10 \quad (2)$$

## 10. Report

10.1 Always report the test temperature and vacuum with the viscosity test result. For example, viscosity at  $60^\circ C$  ( $140^\circ F$ ) [ $140^\circ F$ ] and  $40.0 \text{ kPa}$  [ $300 \text{ mm Hg}$ ] vacuum, in  $Pa \cdot s$ .

## 11. Precision and Bias

11.1 The following criteria (see Note 1) should be used for judging the acceptability of results (95 % probability):

11.1.1 *Repeatability*— Duplicate results by the same operator using the same viscometer should not be considered suspect unless they differ by more than 7 % of their mean.

11.1.2 *Reproducibility*— The results submitted by each of two laboratories should not be considered suspect unless the two results differ by more than 10 % of their mean.

11.2 *Bias*—The bias for this test method cannot be determined because no material with an accepted reference value is available.

## 12. Keywords

12.1 asphalt; capillary; vacuum; viscometer; viscosity

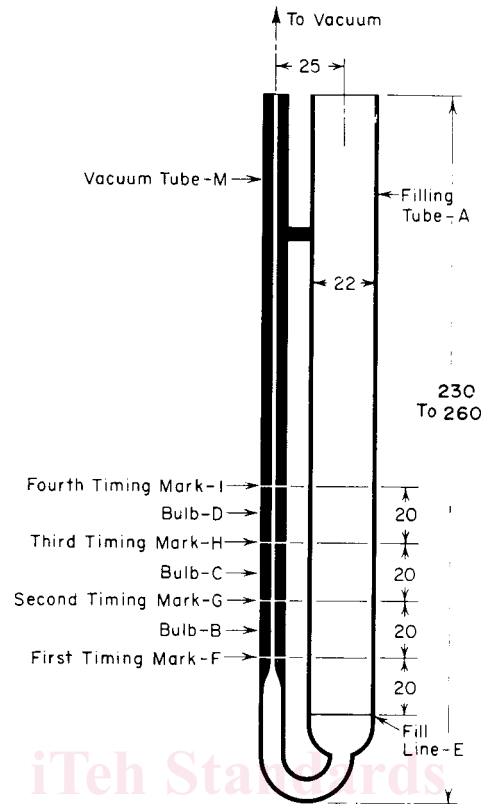

iTeh Standards  
 (https://standards.itih.ai)  
 Document Preview

FIG. 3 Asphalt Institute Vacuum Capillary Viscometer

ASTM D2171/D2171M-10

<https://standards.itih.ai/catalog/standards/sist/97e1ca03-e10b-4286-b79b-d277fde8bf28/astm-d2171-d2171m-10>

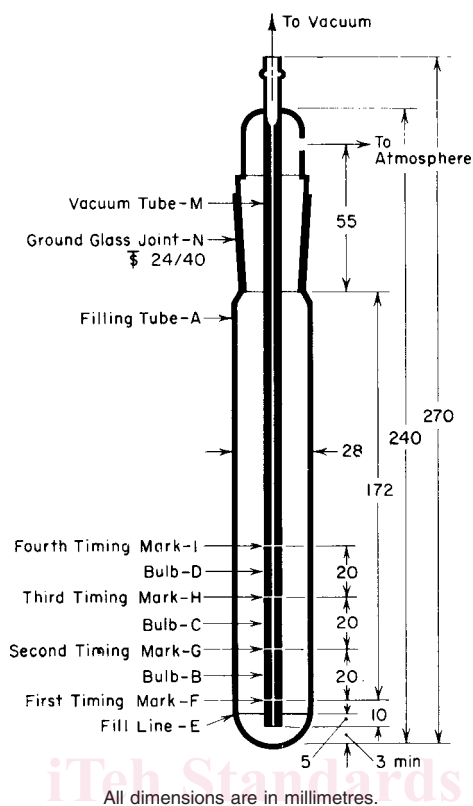

FIG. 4 Modified Koppers Vacuum Capillary Viscometer

## APPENDIXES

### ASTM D2171/D2171M-10 (Nonmandatory Information)

#### X1. CANNON-MANNING VACUUM CAPILLARY VISCOMETER (CMVV)

##### X1.1 Scope

X1.1.1 The Cannon-Manning vacuum capillary viscometer (CMVV)<sup>4,5</sup> is available in eleven sizes (Table X1.1) covering a range from 0.0036 to 8 000 Pa · s (0.036 [0.036 to 80 000 P]-P]. Sizes 10 through 14 are best suited to viscosity measurements of asphalt cements at 60°C (140°F) [140°F].

##### X1.2 Apparatus

X1.2.1 Details of the design and construction of Cannon-Manning vacuum capillary viscometers are shown in Fig. 2. The size numbers, approximate bulb factors,  $K$ , and viscosity ranges for the series of Cannon-Manning vacuum capillary viscometers are given in Table X1.1.

X1.2.2 For all viscometer sizes, the volume of measuring bulb  $C$  is approximately three times that of bulb  $B$ .

X1.2.3 A convenient holder can be made by drilling two holes, 22 and 8 mm in diameter, respectively, through a No. 11 rubber stopper. The center-to-center distance between holes should be 25 mm. Slit through the rubber stopper between holes and also between the 8-mm hole and edge of the stopper. When placed in a 51-mm (2-in.) 50-mm [2-in.] diameter hole in the bath cover, the stopper holds the viscometer in place. Such holders are commercially available.

<sup>4</sup> Griffith, J. M. and Puzinauskas, V.P., "Relation of Empirical Tests to Fundamental Viscosity of Asphalt Cement and the Relative Precision of Data Obtained by Various Tests Methods," *Symposium on Fundamental Viscosity of Bituminous Materials*, ASTM STP 328, Am. Soc. Testing Mats., ASTTA, 1962, pp. 20-44.

<sup>5</sup> Manning, R. E., "Comments on Vacuum Viscometers for Measuring the Viscosity of Asphalt Cements," *Symposium on Fundamental Viscosity of Bituminous Materials*, ASTM STP No. 328, Am. Soc. Testing Mats., ASTTA, 1962, pp. 44-47.