



SLOVENSKI STANDARD
kSIST FprEN 12390-6:2023
01-september-2023

Preskušanje strjenega betona - 6. del: Natezna razcepna trdnost preskušancev

Testing hardened concrete - Part 6: Tensile splitting strength of test specimens

Prüfung von Festbeton - Teil 6: Spaltzugfestigkeit von Probekörpern

Essai pour béton durci - Partie 6 : Détermination de la résistance en traction par fendage d'éprouvettes

Ta slovenski standard je istoveten z: FprEN 12390-6

ICS:

91.100.30 Beton in betonski izdelki Concrete and concrete products

kSIST FprEN 12390-6:2023 **en,fr,de**

EUROPEAN STANDARD
NORME EUROPÉENNE
EUROPÄISCHE NORM

FINAL DRAFT
FprEN 12390-6

July 2023

ICS 91.100.30

Will supersede EN 12390-6:2009

English Version

Testing hardened concrete - Part 6: Tensile splitting strength of test specimens

Essai pour béton durci - Partie 6 : Détermination de la
résistance en traction par fendage d'éprouvettes

Prüfung von Festbeton - Teil 6: Spaltzugfestigkeit von
Probekörpern

This draft European Standard is submitted to CEN members for formal vote. It has been drawn up by the Technical Committee CEN/TC 104.

If this draft becomes a European Standard, CEN members are bound to comply with the CEN/CENELEC Internal Regulations which stipulate the conditions for giving this European Standard the status of a national standard without any alteration.

This draft European Standard was established by CEN in three official versions (English, French, German). A version in any other language made by translation under the responsibility of a CEN member into its own language and notified to the CEN-CENELEC Management Centre has the same status as the official versions.

CEN members are the national standards bodies of Austria, Belgium, Bulgaria, Croatia, Cyprus, Czech Republic, Denmark, Estonia, Finland, France, Germany, Greece, Hungary, Iceland, Ireland, Italy, Latvia, Lithuania, Luxembourg, Malta, Netherlands, Norway, Poland, Portugal, Republic of North Macedonia, Romania, Serbia, Slovakia, Slovenia, Spain, Sweden, Switzerland, Türkiye and United Kingdom.

Recipients of this draft are invited to submit, with their comments, notification of any relevant patent rights of which they are aware and to provide supporting documentation.

Warning : This document is not a European Standard. It is distributed for review and comments. It is subject to change without notice and shall not be referred to as a European Standard.



EUROPEAN COMMITTEE FOR STANDARDIZATION
COMITÉ EUROPÉEN DE NORMALISATION
EUROPÄISCHES KOMITEE FÜR NORMUNG

CEN-CENELEC Management Centre: Rue de la Science 23, B-1040 Brussels

Contents	Page
European foreword.....	3
Introduction	4
1 Scope.....	5
2 Normative references.....	5
3 Terms and definitions	5
4 Principle	5
5 Apparatus.....	5
5.1 Testing machine	5
5.2 Jig (optional).....	6
5.3 Packing strips.....	6
6 Test specimens.....	7
6.1 General.....	7
6.2 Adjustment of test specimens.....	7
6.3 Marking.....	7
7 Procedure.....	7
7.1 Specimen preparation.....	7
7.2 Specimen positioning.....	7
7.3 Loading.....	7
7.4 Examination of specimens.....	8
8 Expression of results.....	8
9 Test report.....	8
10 Precision.....	9
Annex A (normative) Determination of tensile splitting strength using cubic or prismatic specimens	10
A.1 Scope.....	10
A.2 Normative references.....	10
A.3 Principle	10
A.4 Apparatus.....	10
A.5 Test specimens.....	12
A.6 Procedures.....	12
A.7 Expression of results.....	12
A.8 Test report.....	12
A.9 Precision.....	12
Bibliography.....	13

European foreword

This document (FprEN 12390-6:2023) has been prepared by Technical Committee CEN/TC 104 “Concrete and related products”, the secretariat of which is held by SN.

This document is currently submitted to the Formal Vote.

This document will supersede EN 12390-6:2009.

The main change from the previous edition of this document has been to include the testing of cored specimens. The reference specimen for the test is a moulded cylindrical specimen.

This document is one of a series concerned with testing concrete.

EN 12390, *Testing hardened concrete*, consists of the following parts:

- *Part 1: Shape, dimensions and other requirements for specimens and moulds*
- *Part 2: Making and curing specimens for strength tests*
- *Part 3: Compressive strength of test specimens*
- *Part 4: Compressive strength — Specification for testing machines*
- *Part 5: Flexural strength of test specimens*
- *Part 6: Tensile splitting strength of test specimens*
- *Part 7: Density of hardened concrete*
- *Part 8: Depth of penetration of water under pressure*
- *Part 10: Determination of the carbonation resistance of concrete at atmospheric levels of carbon dioxide*
- *Part 11: Determination of the chloride resistance of concrete, unidirectional diffusion*
- *Part 12: Determination of the potential carbonation resistance of concrete: Accelerated carbonation method*
- *Part 13: Determination of secant modulus of elasticity in compression*
- *Part 14: Semi-adiabatic method for the determination of heat released by concrete during its hardening process*
- *Part 15: Adiabatic method for the determination of heat released by concrete during its hardening process*
- *Part 16: Determination of shrinkage of concrete*
- *Part 17: Determination of creep of concrete in compression*
- *Part 18: Determination of chloride migration coefficient*
- *Part 19: Determination of resistivity (in preparation)*

Introduction

This test method was one of a number of test methods examined in a laboratory inter-comparison programme. The work was partly funded by the EC under the Measurement and Testing programme, contract MAT1-CT94-0043. The programme and other references showed the following:

- a) Tensile splitting strengths measured between the normal plane platens of testing machines gave the same results as those using the special curved platens, originally described in ISO 4108:1980 [1]. Although these curved platens have been optionally retained in this document, they are not necessary for the measurement.
- b) The material used for the packing strips affects the apparent tensile strength measured. This has led to the decision to standardize on hardboard strips, since they provided the lowest standard deviations.
- c) The apparent tensile strength measured depends upon the shape and size of the test specimen used:
 - 1) cubes gave higher measured tensile strengths than moulded cylinders, by approximately 10 %;
 - 2) 150 mm cubes gave lower measured tensile strengths than 100 mm cubes;
 - 3) the effect of moulded cylinder size on measured tensile strength was not found to be significant, possibly due to the variability of the data.

As a result of these conclusions from the laboratory programme, this document restricts the measurement of tensile splitting strength to cylindrical specimens used with hardboard packing strips, which is the reference method. However, as some countries still test cubical or prismatic specimens, their use has been retained in Annex A. In cases of dispute, the reference method is the use of moulded cylinders of 150 mm diameter and 300 mm length.

It is recognized good practice to include measurement of density prior to the determination of tensile splitting strength, as a check on compaction.

1 Scope

This document specifies the method for the determination of the tensile splitting strength of test specimens of hardened concrete. The reference specimens are moulded cylindrical specimens.

Cores of at least 75 mm diameter complying with the requirements of EN 12504-1 can be tested using this method.

The use of cubic or prismatic specimens is included in Annex A.

2 Normative references

The following documents are referred to in the text in such a way that some or all of their content constitutes requirements of this document. For dated references, only the edition cited applies. For undated references, the latest edition of the referenced document (including any amendments) applies.

EN 316, *Wood fibre boards — Definition, classification and symbols*

EN 12350-1, *Testing fresh concrete — Part 1: Sampling and common apparatus*

EN 12390-1, *Testing hardened concrete — Part 1: Shape, dimensions and other requirements for specimens and moulds*

EN 12390-2, *Testing hardened concrete — Part 2: Making and curing specimens for strength tests*

EN 12390-4, *Testing hardened concrete — Part 4: Compressive strength — Specification for testing machines*

EN 12504-1, *Testing concrete in structures — Part 1: Cored specimens — Taking, examining and testing in compression*

3 Terms and definitions

No terms and definitions are listed in this document.

ISO and IEC maintain terminology databases for use in standardization at the following addresses:

- ISO Online browsing platform: available at <https://www.iso.org/obp>
- IEC Electropedia: available at <https://www.electropedia.org/>

4 Principle

A cylindrical specimen is subjected to a compressive force applied to a narrow region along its length. The resulting orthogonal tensile force causes the specimen to fail in tension.

The testing of non-cylindrical specimens shall conform to Annex A.

5 Apparatus

5.1 Testing machine

The testing machine shall conform to EN 12390-4. When tests are carried out on cubic or prismatic specimens curved steel loading pieces may be used in place of conventional plane platens.

FprEN 12390-6:2023 (E)

5.2 Jig (optional)

The jig is used for positioning the cylindrical specimen and the packing strips. The jig shall not restrict the deformation of the specimen during the test.

5.3 Packing strips

Packing strips shall conform to EN 316, made of hardboard of density equal or greater than 900 kg/m^3 and dimensions width (a) = $(15 \pm 1) \text{ mm}$; thickness (t) = $(4 \pm 1) \text{ mm}$ and a length greater than the length of the line of contact of the test specimen.

Alternatively, packing strips may be used if they meet the following hardness criterion:

When submitted to a punching test by means of a rod of circular cross section, having a diameter of $(16 \pm 0,5) \text{ mm}$ and applying a force at a rate of $(48 \pm 10) \text{ kN/min}$, the instantaneous penetration when the force of $(20 \pm 5) \text{ kN}$ is achieved shall be equal to $(1,2 \pm 0,4) \text{ mm}$.

Packing strips shall be used only once.

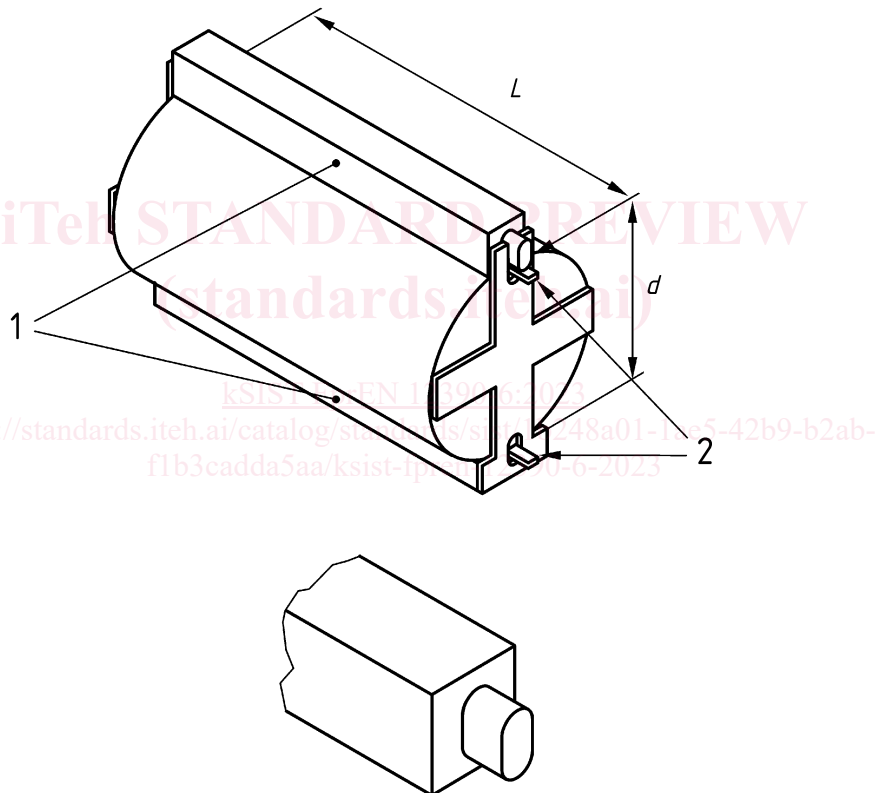

Key

- 1 steel loading piece
- 2 hardboard packing strips
- L length of specimen
- d diameter of specimen

Figure 1 — Jig for testing cylindrical specimens

6 Test specimens

6.1 General

The test specimens shall be cylindrical, conforming to EN 12390-1, but a length/diameter ratio as low as 1 shall be acceptable for cores. Specimens cast in moulds shall conform to EN 12390-1 and EN 12390-2. Cores shall conform to EN 12504-1 and shall have a diameter of at least 75 mm and shall not contain reinforcement.

The specimens shall be examined, and any abnormalities observed shall be reported.

6.2 Adjustment of test specimens

Where the dimensions or shapes of the test surfaces of the specimens do not conform to EN 12390-1, because they exceed the respective tolerances, they shall be rejected or adjusted to comply with the following requirements:

- a) uneven surfaces shall be levelled by grinding;
- b) the deviation of angles shall be corrected by cutting and/or grinding.

6.3 Marking

Unless a centring jig is used, two lines shall be marked along which to apply the load. These lines shall be opposite each other in an axial plane and the extremities of the two lines shall be connected over each end of the specimen, to clearly define the plane of loading.

7 Procedure

7.1 Specimen preparation

For specimens stored in water, wipe any excess moisture from the surface of the specimen before placing in the testing machine.

Wipe the bearing surfaces of the jig, packing strips, loading pieces and platens. Clean and remove any loose grit or other extraneous material from the surface of the specimen that will be in contact with the packing strips.

7.2 Specimen positioning

Place the test specimen centrally in the testing machine, optionally using a jig. Carefully place packing strips and, if required, loading pieces, along the top and bottom of the plane of loading of the specimen.

Ensure that the upper platen is parallel with the lower platen, during loading.

7.3 Loading

Ensure that the specimen remains centred when the load is first applied, either by means of a jig or by temporary supports.

Select a constant rate of stress within the range 0,04 MPa/s to 0,06 MPa/s. After the application of the initial load, which does not exceed approximately 20 % of the failure load, apply the load to the specimen without shock and increase continuously, at the selected constant rate ± 10 %, until no greater load can be sustained.

FprEN 12390-6:2023 (E)

The required loading rate is given in Formula (1):

$$R = \frac{s \times \pi \times L \times d}{2} \quad (1)$$

where

- R is the required loading rate, in Newtons per second (N/s);
- L is the length of the specimen, in millimetres (mm) (see Figure 1);
- d is the designated cross-sectional dimension, in millimetres (mm);
- s is the stress rate, in megapascals per second (MPa/s).

When using manually controlled testing machines, correct any tendency for the selected rate of loading to decrease, as specimen failure is approached, by appropriate adjustment of the controls.

When using automatically controlled testing machines, check the rate of loading periodically, to ensure that the rate is constant.

Record the maximum load indicated.

7.4 Examination of specimens

Examine the fractured specimens and the appearance of the concrete and record, if unusual.

8 Expression of results

The tensile splitting strength is given in Formula (2):

$$f_{ct} = \frac{2 \times F}{\pi \times L \times d} \quad (2)$$

where

- f_{ct} is the tensile splitting strength, in megapascals (MPa);
- F is the maximum load, in Newtons (N);
- L is the length of the line of contact of the specimen, in millimetres (mm);
- d is the designated cross-sectional dimension, in millimetres (mm).

NOTE The tensile splitting strength is expressed to the nearest 0,05 MPa.

For deviations from the standard method with respect to the dimensions of the specimen, the strength calculation may be based on the actual dimensions of the test specimen.

9 Test report

The test report shall include:

- a) a reference to this document;
- b) identification of the test specimen;
- c) type of specimen: cylinder (moulded), cube, prism or core;