

ISO/TC 8/SC 4

Secretariat: SAC

Voting begins on:
2020-05-27

Voting terminates on:
2020-07-22

Ships and marine technology — Ship's mooring and towing fittings — Shipside roller fairleads

*Navires et technologie maritime — Corps-morts et ferrures de
remorquage de navires — Chaumards à rouleaux à quai*

ITeH STANDARD PREVIEW
(standards.iteh.ai)
Full standard:
<https://standards.iteh.ai/catalog/standards/sist/cd77660e-e147-4b75-9611-188b5afda7a3/iso-fdis-13767>

RECIPIENTS OF THIS DRAFT ARE INVITED TO SUBMIT, WITH THEIR COMMENTS, NOTIFICATION OF ANY RELEVANT PATENT RIGHTS OF WHICH THEY ARE AWARE AND TO PROVIDE SUPPORTING DOCUMENTATION.

IN ADDITION TO THEIR EVALUATION AS BEING ACCEPTABLE FOR INDUSTRIAL, TECHNOLOGICAL, COMMERCIAL AND USER PURPOSES, DRAFT INTERNATIONAL STANDARDS MAY ON OCCASION HAVE TO BE CONSIDERED IN THE LIGHT OF THEIR POTENTIAL TO BECOME STANDARDS TO WHICH REFERENCE MAY BE MADE IN NATIONAL REGULATIONS.



Reference number
ISO/FDIS 13767:2020(E)

iTeh STANDARD PREVIEW
(standards.iteh.ai)
Full standard:
<https://standards.iteh.ai/catalog/standards/sist/cd73660a-e147-4b75-9611-188b5afda7a3/iso-fdis-13767>



COPYRIGHT PROTECTED DOCUMENT

© ISO 2020

All rights reserved. Unless otherwise specified, or required in the context of its implementation, no part of this publication may be reproduced or utilized otherwise in any form or by any means, electronic or mechanical, including photocopying, or posting on the internet or an intranet, without prior written permission. Permission can be requested from either ISO at the address below or ISO's member body in the country of the requester.

ISO copyright office
CP 401 • Ch. de Blandonnet 8
CH-1214 Vernier, Geneva
Phone: +41 22 749 01 11
Fax: +41 22 749 09 47
Email: copyright@iso.org
Website: www.iso.org

Published in Switzerland

Contents

	Page
Foreword	iv
Introduction	v
1 Scope	1
2 Normative references	1
3 Terms and definitions	1
4 Classification	1
4.1 Type	1
4.2 Nominal sizes	1
5 Dimensions	2
6 Materials	2
7 Manufacturing and inspection	2
8 Marking	2
Annex A (normative) Basis for strength assessment of shiplside roller fairleads	6
Bibliography	10

iTeh STANDARD PREVIEW
 (standards.iteh.ai)
 Full standard:
<https://standards.iteh.ai/catalog/standards/sist/cd736603-e147-4b75-9611-188b5afda7a3/iso-fdis-13767>

Foreword

ISO (the International Organization for Standardization) is a worldwide federation of national standards bodies (ISO member bodies). The work of preparing International Standards is normally carried out through ISO technical committees. Each member body interested in a subject for which a technical committee has been established has the right to be represented on that committee. International organizations, governmental and non-governmental, in liaison with ISO, also take part in the work. ISO collaborates closely with the International Electrotechnical Commission (IEC) on all matters of electrotechnical standardization.

The procedures used to develop this document and those intended for its further maintenance are described in the ISO/IEC Directives, Part 1. In particular, the different approval criteria needed for the different types of ISO documents should be noted. This document was drafted in accordance with the editorial rules of the ISO/IEC Directives, Part 2 (see www.iso.org/directives).

Attention is drawn to the possibility that some of the elements of this document may be the subject of patent rights. ISO shall not be held responsible for identifying any or all such patent rights. Details of any patent rights identified during the development of the document will be in the Introduction and/or on the ISO list of patent declarations received (see www.iso.org/patents).

Any trade name used in this document is information given for the convenience of users and does not constitute an endorsement.

For an explanation of the voluntary nature of standards, the meaning of ISO specific terms and expressions related to conformity assessment, as well as information about ISO's adherence to the World Trade Organization (WTO) principles in the Technical Barriers to Trade (TBT), see www.iso.org/iso/foreword.html.

This document was prepared Technical Committee ISO/TC 8, *Ships and marine technology*, Subcommittee SC 4, *Outfitting and deck machinery*.

This second edition cancels and replaces the first edition (ISO 13767:2012), which has been technically revised.

The main changes compared to the previous edition are as follows:

- the definition of SWL (3.1) has been reworded;
- the column headings in Table 1 have been amended;
- the mark numbers in Figure 2 have been amended;
- technical information on FEM has been added in A.3.1.

Any feedback or questions on this document should be directed to the user's national standards body. A complete listing of these bodies can be found at www.iso.org/members.html.

Introduction

The shipside roller fairlead is a type of ship's mooring fitting installed on board to lead the mooring rope from the ship's inboard to outboard.

iTeh STANDARD PREVIEW
(standards.iteh.ai)
Full standard:
<https://standards.iteh.ai/catalog/standards/sist/cd73660a-e147-4b75-9611-188b5afda7a3/iso-fdis-13767>

iTeh STANDARD PREVIEW
(standards.iteh.ai)

Full standard:
<https://standards.iteh.ai/catalog/standards/sist/cd73660a-e147-4b75-9611-188b5afda7a3/iso-fdis-13767>

Ships and marine technology — Ship's mooring and towing fittings — Shiplside roller fairleads

1 Scope

This document specifies the types, nominal sizes, dimensions and materials, as well as construction, manufacturing and marking requirements, for shiplside roller fairleads installed to lead the mooring rope of a ship.

2 Normative references

The following documents are referred to in the text in such a way that some or all of their content constitutes requirements of this document. For dated references, only the edition cited applies. For undated references, the latest edition of the referenced document (including any amendments) applies.

ISO 13755, *Ships and marine technology — Ship's mooring and towing fittings — Steel rollers*

IMO Circular MSC/Circ.1175, *Guidance on shipboard towing and mooring equipment*

3 Terms and definitions

For the purposes of this document, the following terms and definitions apply.

ISO and IEC maintain terminological databases for use in standardization at the following addresses:

- ISO Online browsing platform: available at <https://www.iso.org/obp>
- IEC Electropedia: available at <http://www.electropedia.org/>

3.1

safe working load

SWL

safe load limit (maximum permissible load) of the fittings used for mooring and towing

4 Classification

4.1 Type

Depending on the construction, roller fairleads shall be classified as belonging to one of the following two types:

- a) 2-roller type;
- b) 3-roller type.

4.2 Nominal sizes

The nominal sizes, D_n , of roller fairleads are denoted by reference to the outside diameter of the roller, in millimetres, from a basic series of preferred numbers.

The nominal sizes are: 150, 200, 250, 300, 350, 400, 450 and 500.

5 Dimensions

Roller fairleads shall have dimensions and particulars in accordance with [Tables 1](#) and [2](#), and [Figures 1](#) and [2](#).

6 Materials

The following material shall be used for manufacturing the roller fairleads:

- seat: weldable steel plates having a yield point of not less than 235 N/mm².

7 Manufacturing and inspection

7.1 All surfaces of the roller fairleads, including welded surfaces, shall be free from any visible flaws or imperfections.

7.2 All surfaces in contact with the ropes shall be free from surface roughness or irregularities likely to cause damage to the ropes by abrasion.

7.3 The roller fairleads shall be coated externally with an anti-corrosion protective finish.

8 Marking

8.1 The safe working load (SWL) for the intended use of the roller fairleads shall be noted in the towing and mooring plan available on board for the guidance of the shipmaster as specified in IMO circular MSC/Circ.1175.

8.2 The actual SWL on board shall be determined by considering the under deck reinforcement, and it shall be marked on the towing and mooring plan. The actual SWL shall not be over the SWL indicated in this document.

8.3 The shipside roller fairleads shall be clearly marked with its SWL by weld bead or equivalent. The SWL shall be expressed in tonnes (symbol 't') and be placed so that it is not obscured during operation of the fitting.

EXAMPLE SWL XXX t

Dimensions in millimetres

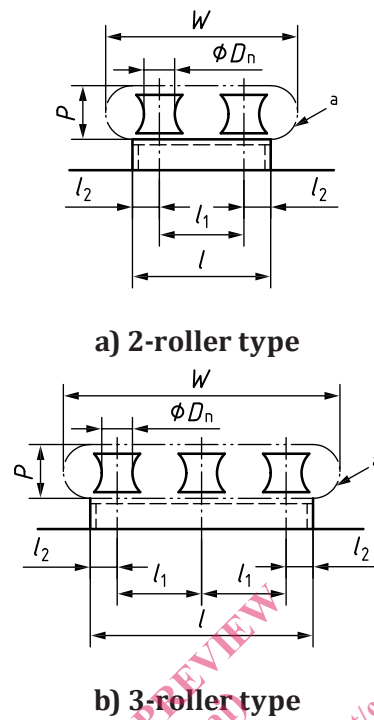

a Opening on shell/bulwark.

Figure 1 — Layout of roller fairleads

Table 1 — Dimensions and SWL of roller fairleads

Dimensions in millimetres

Nominal size D_n	2-roller type		3-roller type		l_1	l_2	P^c	SWL ^b			
	l	W^c	l	W^c				$\theta = 90^\circ$ ^a		$\theta = 20^\circ$	
								kN	t	kN	t
150	570	770	870	1 070	300	135	200	260	26	186	19
200	740	990	1 140	1 390	400	170	250	437	45	314	32
250	910	1 210	1 410	1 710	500	205	300	574	58	412	42
300	1 070	1 420	1 670	2 020	600	235	350	710	72	510	52
350	1 230	1 610	1 930	2 310	700	265	380	1 025	104	736	75
400	1 400	1 780	2 200	2 580	800	300	380	1 230	125	883	90
450	1 560	1 940	2 460	2 840	900	330	380	1 571	160	1 128	115
500	1 720	2 100	2 720	3 100	1 000	360	380	1 913	195	1 373	140

^a θ is the relative angle of ropes on the roller fairlead (refer to Annex A).

^b The “SWL” which is marked on the fitting is the maximum applicable rope tension based on a 90° ($\theta = 90^\circ$) and a 160° ($\theta = 20^\circ$) deflections of the rope direction by the roller fairlead.

The SWLs shown in this table are for reference only. These are based on the loadings as mentioned in Annex A.

The “SWL” which is marked on the fitting may be adjusted depending on the actual loading conditions of mooring rope under the agreement between the user and the manufacturer.

^c P and W are for reference only. The opening size on the shell or bulwark shall be determined considering overhauling space of the roller.