



Designation: ~~C941-02~~ Designation: C941 - 10

# Standard Test Method for Water Retentivity of Grout Mixtures for Preplaced-Aggregate Concrete in the Laboratory<sup>1</sup>

This standard is issued under the fixed designation C941; the number immediately following the designation indicates the year of original adoption or, in the case of revision, the year of last revision. A number in parentheses indicates the year of last reapproval. A superscript epsilon ( $\epsilon$ ) indicates an editorial change since the last revision or reapproval.

## 1. Scope\*

1.1 This test method covers the procedure for determining the water retentivity of freshly mixed hydraulic cement grout mixtures for preplaced-aggregate (PA) concrete.

1.2 The values stated in SI units are to be regarded as the standard. The values given in parentheses are for information only.

1.3 *This standard does not purport to address all of the safety concerns, if any, associated with its use. It is the responsibility of the user of this standard to establish appropriate safety and health practices and determine the applicability of regulatory limitations prior to use.*

## 2. Referenced Documents

2.1 *ASTM Standards:*<sup>2</sup>

C125 [Terminology Relating to Concrete and Concrete Aggregates](#)

C219 [Terminology Relating to Hydraulic Cement](#)

E832 [Specification for Laboratory Filter Papers](#)

## 3. Summary of Test Method

~~3.1 The time required for the extraction of a standard amount of water by vacuum from a grout sample is measured.~~ [Terminology](#)

~~3.1 Definitions:~~

~~3.1.1 For definitions of terms used in this test method, refer to Terminologies C125 and C219.~~

## 4. Significance and Use

~~4.1 This test method measures the ability of a grout mixture to retain its mixing water.~~

~~4.2 It is used for qualifying grout fluidifiers to be used in the production of PA concrete.~~

~~4.3 It may be used to compare the effects of various admixtures or materials combinations on the water retentivity properties of any cement-water grout.~~ [Summary of Test Method](#)

~~4.1 The time required for the extraction of a standard amount of water by vacuum from a grout sample is measured.~~

## 5. Significance and Use

~~5.1 This test method measures the ability of a grout mixture to retain its mixing water.~~

~~5.2 It is used for qualifying grout fluidifiers to be used in the production of PA concrete.~~

~~5.3 It may be used to compare the effects of various admixtures or materials combinations on the water retentivity properties of any cement-water grout.~~

## 6. Apparatus

~~5.1~~

~~6.1 Extraction Apparatus, assembled as in Fig. 1, including the following:~~

~~5.1.1~~

~~6.1.1 Funnel, porcelain Büchner filtering, 111 mm inside diameter at the perforated plate and 500 mL in volume.~~

~~5.1.2~~

<sup>1</sup> This test method is under the jurisdiction of ASTM Committee C09 on Concrete and Concrete Aggregates and is the direct responsibility of Subcommittee C09.41 on Concrete for Radiation Shielding.

~~Current edition approved Dec. 10, 2002. Published February 2003. Originally approved in 1981. Last previous edition approved in 1996 as C941-96. DOI: 10.1520/C0941-02 on Hydraulic Cement Grouts.~~

~~Current edition approved June 15, 2010. Published July 2010. Originally approved in 1981. Last previous edition approved in 2002 as C941-02. DOI: 10.1520/C0941-10.~~

<sup>2</sup> For referenced ASTM standards, visit the ASTM website, [www.astm.org](http://www.astm.org), or contact ASTM Customer Service at [service@astm.org](mailto:service@astm.org). For *Annual Book of ASTM Standards* volume information, refer to the standard's Document Summary page on the ASTM website.

\*A Summary of Changes section appears at the end of this standard.

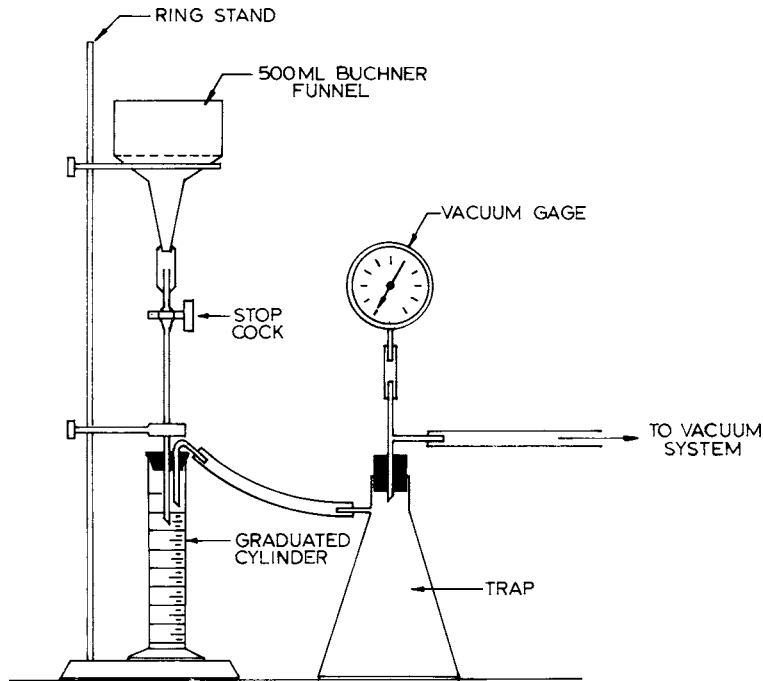

FIG. 1 Extraction Apparatus

6.1.2 *Filter Paper*, Specification E832, Type 2, Class G, disk, 11-cm diameter filter paper.

5.1.3

6.1.3 *Graduated Cylinder*, 250 mL cut down to about 130 mL.

5.1.4

6.1.4 *Vacuum Gage* or manometer graduated in increments of 1 kPa to 100 kPa (30-in. Hg) vacuum.

5.1.5

6.1.5 *Vacuum Pump* or other source of reduced pressure, capable of maintaining a minimum vacuum of 95 kPa (28 in. Hg) on a system having a volume of not less than 1 L.

5.2

6.2 *Stop Watch*, having a least reading of not more than 0.2 s.

5.3

6.3 *Thermometer*, accurate to 0.5°C (1.0°F), for measuring ambient and grout temperatures.

## 6. Sampling

6.1 The test sample shall consist of at least 500 mL of freshly mixed grout representative of grout in the mixer. The temperature of the laboratory sample of grout shall be  $23.0 \pm 2.0^\circ\text{C}$  ( $73.5 \pm 3.5^\circ\text{F}$ ).

## 7. Sampling

7.1 The test sample shall consist of at least 500 mL of freshly mixed grout representative of grout in the mixer. The temperature of the laboratory sample of grout shall be  $23.0 \pm 2.0^\circ\text{C}$  ( $73.5 \pm 3.5^\circ\text{F}$ ).

## 8. Procedure

7.1 Dampen a single filter paper disk and place it on the perforated plate of the filtering funnel (see Fig. 1). Keep the top of the filtering funnel level. Apply to and maintain a minimum vacuum in the system below the stopcock of 95 kPa (28 in. Hg) for the duration of the test. Introduce grout into the funnel until it is filled flush with the top. Open the stopcock between the filtering funnel and the graduated cylinder and at the same time start the stop watch. Perform these operations not more than 1 min after taking the grout sample from the mixer.

7.2 When 60 mL of water have been removed from the sample, stop the stop watch.

7.3 When using this method for acceptance testing of a grout fluidifier, take the test sample within 1 min after completion of 3 to 3 1/4 min mixing.

## 8. Report

8.1 Report the following information:

8.1.1 Identification of the grout sample;