



Designation: ~~C943-02~~ Designation: C943 - 10

# Standard Practice for Making Test Cylinders and Prisms for Determining Strength and Density of Preplaced-Aggregate Concrete in the Laboratory<sup>1</sup>

This standard is issued under the fixed designation C943; the number immediately following the designation indicates the year of original adoption or, in the case of revision, the year of last revision. A number in parentheses indicates the year of last reapproval. A superscript epsilon ( $\epsilon$ ) indicates an editorial change since the last revision or reapproval.

## 1. Scope\*

1.1 This practice covers procedures for making standard test cylinders used to determine the compressive strength and density of preplaced-aggregate (PA) concrete.

1.2 The values stated in SI units are to be regarded as the standard. The values given in parentheses are for information only.

1.3 *This standard does not purport to address all of the safety concerns, if any, associated with its use. It is the responsibility of the user of this standard to establish appropriate safety and health practices and determine the applicability of regulatory limitations prior to use.*

## 2. Referenced Documents

2.1 *ASTM Standards:*<sup>2</sup>

C125 [Terminology Relating to Concrete and Concrete Aggregates](#)

C192/C192M [Practice for Making and Curing Concrete Test Specimens in the Laboratory](#)

C219 [Terminology Relating to Hydraulic Cement](#)

C637 [Specification for Aggregates for Radiation-Shielding Concrete](#)

C937 [Specification for Grout Fluidifier for Preplaced-Aggregate Concrete](#)

C938 [Practice for Proportioning Grout Mixtures for Preplaced-Aggregate Concrete](#)

C939 [Test Method for Flow of Grout for Preplaced-Aggregate Concrete \(Flow Cone Method\)](#)

C940 [Test Method for Expansion and Bleeding of Freshly Mixed Grouts for Preplaced-Aggregate Concrete in the Laboratory](#)

## 3. Summary of Practice

~~3.1 Coarse aggregate is placed in a standard cylinder mold having end plates to which pipe fittings have been attached. Grout is pumped into the mold until full. The test cylinder, demolded after hardening, may be cured and used for determination of strength or cut into prisms for the determination of unit weight. Terminology~~

### 3.1 Definitions:

3.1.1 For definitions of terms used in this test method, refer to Terminologies C125 and C219.

## 4. Significance and Use

~~4.1 This practice is used for making test cylinders or prisms of PA concrete. Cylinders are used for determining compressive strength and approximate density. Prisms, cut from cylinders, eliminate the surface effect and thus more accurately represent the actual density of PA concrete in place. Summary of Practice~~

~~4.1 Coarse aggregate is placed in a standard cylinder mold having end plates to which pipe fittings have been attached. Grout is pumped into the mold until full. The test cylinder, demolded after hardening, may be cured and used for determination of strength or cut into prisms for the determination of unit weight.~~

## 5. Significance and Use

5.1 This practice is used for making test cylinders or prisms of PA concrete. Cylinders are used for determining compressive

<sup>1</sup> This practice is under the jurisdiction of ASTM Committee C09 on Concrete and Concrete Aggregates and is the direct responsibility of Subcommittee C09.41 on Concrete for Radiation Shielding.

Current edition approved Dec. 10, 2002. Published February 2003. Originally approved in 1980. Last previous edition approved in 1996 as C943-96. DOI: 10.1520/C0943-02. on Hydraulic Cement Grouts.

Current edition approved June 15, 2010. Published July 2010. Originally approved in 1980. Last previous edition approved in 2002 as C943-02. DOI: 10.1520/C0943-10.

<sup>2</sup> For referenced ASTM standards, visit the ASTM website, [www.astm.org](http://www.astm.org), or contact ASTM Customer Service at [service@astm.org](mailto:service@astm.org). For *Annual Book of ASTM Standards* volume information, refer to the standard's Document Summary page on the ASTM website.

\*A Summary of Changes section appears at the end of this standard.

strength and approximate density. Prisms, cut from cylinders, eliminate the surface effect and thus more accurately represent the actual density of PA concrete in place.

## 6. Apparatus

5.1

6.1 *Cylinder Molds* (Fig. 1), cast iron or steel, for making 150 by 300-mm (6 by 12-in.) cylinders. Base and top plates shall be arranged for tight assembly to the cylinder. All mating and inside surfaces shall be machined smooth such that the assembled mold will be essentially watertight. End plates shall be drilled and tapped at their centers for standard 19 mm (¾-in.) pipe nipples. The top end plate shall also be perforated, as shown in Fig. 2.

5.2

6.2 *Venting Fabric*, white cotton cloth, free of oil and grease.

5.3

6.3 *Grouting Apparatus* (Fig. 3), capable of delivering grout at a uniform rate of 1.4 to 2.8 L (0.05 to 0.10 ft<sup>3</sup>)/min at pressures up to 345 kPa (50 psi).

5.4

6.4 *Mallet*, with rubber or rawhide head weighing approximately ¼ kg (½ lb).

5.5

6.5 *Platform Scales*, accurate to within 0.3 % of the test load at any point within the range of use.

5.6

6.6 *Stop Watch*, least reading not more than 0.2 s.

5.7

6.7 *Flow Cone*—See Test Method C939.

5.8

6.8 *Thermometer*, accurate to 0.5°C (1°F), for measuring ambient and grout temperatures.

6.

## 7. Materials

6.1

7.1 *Coarse Aggregate*—Except when tests are made for specific projects, coarse aggregate shall conform to the requirements of Specification C637, Table number 2, Coarse Aggregate, Grading 1, unless Grading 2 is specified.

6.2

7.2 *Grout*—Except when tests are made for specific projects, grout ingredients, proportioning, and mixing shall be in accordance with Practice C938.

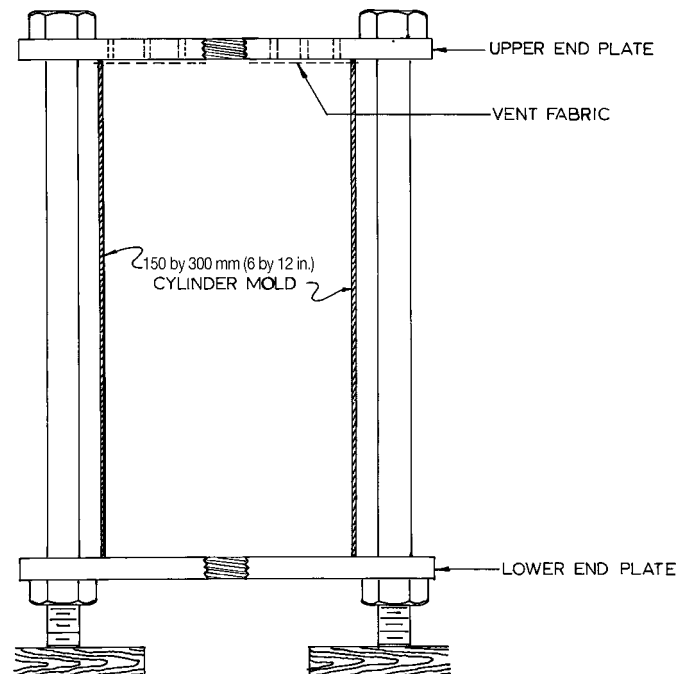
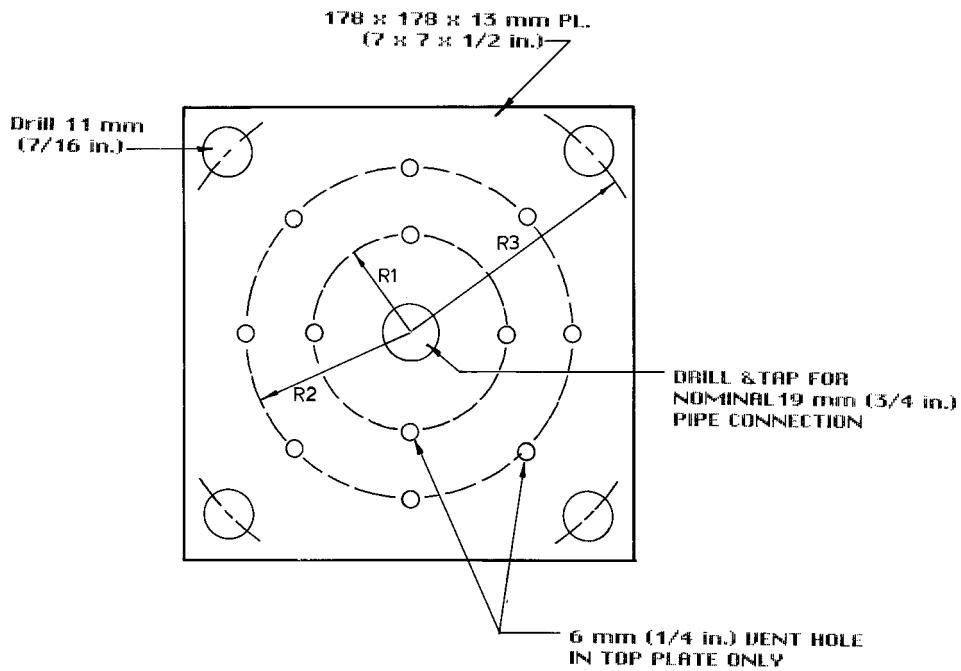
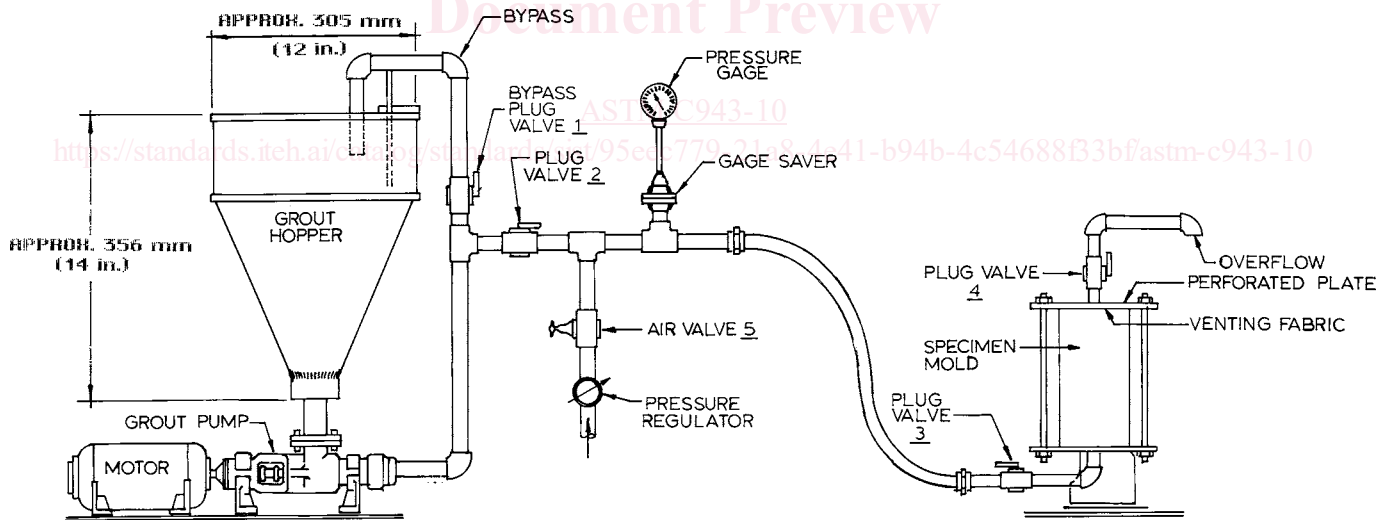

FIG. 1 Cylinder Mold Assembly Cross Section



R1=38 mm (1 1/2 in.)  
 R2=64 mm (2 1/2 in.)  
 R3=101 mm (4 in.)

FIG. 2 End Plate Details



NOTE 1—Grout hose pipe and fittings 25 mm (1 in.) nominal.

FIG. 3 Typical Grouting Apparatus

6.3

7.3 Tests for Specific Projects—When tests are to be made for specific projects, materials shall be representative of those in use or proposed for use in the work.

6.3.1 If not taken from project-mixed grout being used in the work, grout materials shall be mixed in the laboratory using the procedure described in Specification C937.

7. Sampling

7.1 Coarse aggregate shall be representative of material used or to be used in the work or of that tested and stockpiled for test work.