**Ships and marine technology —
Ship's mooring and towing fittings —
Mooring chocks**

*Navires et technologie maritime — Corps-morts et ferrures de
remorquage de navires — Chaumards*

iTeh STANDARD PREVIEW
(standards.iteh.ai)

[ISO 13713:2020](https://standards.iteh.ai/catalog/standards/sist/8f9e3d14-e1b3-4ffe-9862-1e26f5226a44/iso-13713-2020)

<https://standards.iteh.ai/catalog/standards/sist/8f9e3d14-e1b3-4ffe-9862-1e26f5226a44/iso-13713-2020>



iTeh STANDARD PREVIEW
(standards.iteh.ai)

ISO 13713:2020

<https://standards.iteh.ai/catalog/standards/sist/8f9e3d14-e1b3-4ffe-9862-1e26f5226a44/iso-13713-2020>



COPYRIGHT PROTECTED DOCUMENT

© ISO 2020

All rights reserved. Unless otherwise specified, or required in the context of its implementation, no part of this publication may be reproduced or utilized otherwise in any form or by any means, electronic or mechanical, including photocopying, or posting on the internet or an intranet, without prior written permission. Permission can be requested from either ISO at the address below or ISO's member body in the country of the requester.

ISO copyright office
CP 401 • Ch. de Blandonnet 8
CH-1214 Vernier, Geneva
Phone: +41 22 749 01 11
Email: copyright@iso.org
Website: www.iso.org

Published in Switzerland

Contents

	Page
Foreword	iv
Introduction	v
1 Scope	1
2 Normative references	1
3 Terms and definitions	1
4 Classification	1
4.1 Type	1
4.2 Nominal sizes	1
5 Dimensions	2
6 Materials	2
7 Construction	2
8 Manufacturing and inspection	2
9 Marking	2
Annex A (normative) Basis for strength assessment of mooring chocks	7
Bibliography	11

iTeh STANDARD PREVIEW (standards.iteh.ai)

[ISO 13713:2020](https://standards.iteh.ai/catalog/standards/sist/8f9e3d14-e1b-4ffe-9862-1e26f5226a44/iso-13713-2020)

<https://standards.iteh.ai/catalog/standards/sist/8f9e3d14-e1b-4ffe-9862-1e26f5226a44/iso-13713-2020>

Foreword

ISO (the International Organization for Standardization) is a worldwide federation of national standards bodies (ISO member bodies). The work of preparing International Standards is normally carried out through ISO technical committees. Each member body interested in a subject for which a technical committee has been established has the right to be represented on that committee. International organizations, governmental and non-governmental, in liaison with ISO, also take part in the work. ISO collaborates closely with the International Electrotechnical Commission (IEC) on all matters of electrotechnical standardization.

The procedures used to develop this document and those intended for its further maintenance are described in the ISO/IEC Directives, Part 1. In particular, the different approval criteria needed for the different types of ISO documents should be noted. This document was drafted in accordance with the editorial rules of the ISO/IEC Directives, Part 2 (see www.iso.org/directives).

Attention is drawn to the possibility that some of the elements of this document may be the subject of patent rights. ISO shall not be held responsible for identifying any or all such patent rights. Details of any patent rights identified during the development of the document will be in the Introduction and/or on the ISO list of patent declarations received (see www.iso.org/patents).

Any trade name used in this document is information given for the convenience of users and does not constitute an endorsement.

For an explanation of the voluntary nature of standards, the meaning of ISO specific terms and expressions related to conformity assessment, as well as information about ISO's adherence to the World Trade Organization (WTO) principles in the Technical Barriers to Trade (TBT), see www.iso.org/iso/foreword.html.

This document was prepared Technical Committee ISO/TC 8, *Ships and marine technology*, Subcommittee SC 4, *Outfitting and deck machinery*.

This second edition cancels and replaces the first edition (ISO 13713:2012), which has been technically revised.

The main changes compared to the previous edition are as follows:

- technical guidelines have been added in [7.2](#);
- the definition of SWL ([3.1](#)) has been reworded;
- the leader line in [Figure 1](#) has been amended;
- technical information on FEM has been added in [A.3.2](#).

Any feedback or questions on this document should be directed to the user's national standards body. A complete listing of these bodies can be found at www.iso.org/members.html.

Introduction

The mooring chock is a type of ship's mooring and towing fitting installed on the shipside to lead the mooring and towing rope from the ship's inboard to outboard.

The mooring chocks are normally adopted for ships which use nylon or other synthetic ropes other than wire ropes considering the small bending ratio (for wire ropes, see ISO 13729).

iTeh STANDARD PREVIEW
(standards.iteh.ai)

ISO 13713:2020

<https://standards.iteh.ai/catalog/standards/sist/8f9e3d14-e1b-4ffe-9862-1e26f5226a44/iso-13713-2020>

iTeh STANDARD PREVIEW
(standards.iteh.ai)

ISO 13713:2020

<https://standards.iteh.ai/catalog/standards/sist/8f9e3d14-e1b3-4ffe-9862-1e26f5226a44/iso-13713-2020>

Ships and marine technology — Ship's mooring and towing fittings — Mooring chocks

1 Scope

This document specifies the types, nominal sizes, dimensions and materials, as well as construction, manufacturing and marking requirements, for mooring chocks installed to lead the mooring and towing rope of a ship.

2 Normative references

The following documents are referred to in the text in such a way that some or all of their content constitutes requirements of this document. For dated references, only the edition cited applies. For undated references, the latest edition of the referenced document (including any amendments) applies.

IMO Circular MSC/Circ.1175, *Guidance on shipboard towing and mooring equipment*

3 Terms and definitions

For the purposes of this document, the following terms and definitions apply.

ISO and IEC maintain terminological databases for use in standardization at the following addresses:

- ISO Online browsing platform: available at <https://www.iso.org/obp>
- IEC Electropedia: available at <http://www.electropedia.org/>

3.1

safe working load

SWL

safe load limit (maximum permissible load) of the fittings used for mooring and towing

4 Classification

4.1 Type

The mooring chocks shall be classified by its installation site as belonging to one of the following types:

- a) Type A: deck-mounted mooring chock;
- b) Type B: bulwark-mounted mooring chock.

4.2 Nominal sizes

The nominal sizes, $L \times H$, of mooring chocks are denoted by reference to the width and height of the opening of the chock, in millimetres. For the mooring chocks having the same size, the letter of the alphabet, i.e. A or B, is followed by the nominal size for the different safe working loads (SWL).

The nominal sizes are: 250 × 200, 300 × 250, 350 × 250, 400 × 250, 450 × 250, 500 × 250A, 500 × 250B

5 Dimensions

The mooring chocks shall have dimensions and particulars in accordance with [Tables 1, 2, 3 and 4](#), and [Figures 1 and 2](#).

6 Materials

The following material shall be used for manufacturing the mooring chocks:

- steel casting material having a yield point of not less than 235 N/mm² or equivalent.

The carbon contents of the steel casting shall not be more than 0,23 % considering weldability.

7 Construction

7.1 The foundation of the mooring chocks shall be determined by considering the actual load direction. The foundation and welding connections to the hull shall guarantee a reliable transmission of the maximum loading of the mooring chocks to the hull construction without any plastic deformation or cracks.

7.2 The tensile strength of the mooring rope may be reduced depending on the bend radius (D/d ratio) through the mooring fittings, in accordance with the rope manufacturer's guidelines.

8 Manufacturing and inspection

8.1 All surfaces of the mooring chocks, including welded surfaces, shall be free from any visible flaws or imperfections.

8.2 All surfaces in contact with the ropes shall be free from surface roughness or irregularities likely to cause damage to the ropes by abrasion.

8.3 The mooring chocks shall be coated externally with an anti-corrosion protective finish.

9 Marking

9.1 The SWL for the intended use of the mooring chocks shall be noted in the towing and mooring plan available on board for the guidance of the shipmaster, as specified in IMO circular MSC/Circ.1175.

9.2 The actual SWL on board shall be determined by considering the foundation and under deck reinforcement, and it shall be marked on the towing and mooring plan. The actual SWL shall not be over the SWL indicated in this document.

9.3 The mooring chock shall be clearly marked with its SWL by weld bead or equivalent. The SWL shall be expressed in tonnes (symbol 't') and be placed so that it is not obscured during operation of the fitting.

EXAMPLE SWL XXX t

9.4 The SWL mark shall be placed on the foundation of the chock or on the deck.

9.5 The radii of edges and corners not shown in [Figures 1 and 2](#) shall be of minimum 25 mm.

Dimensions in millimetres

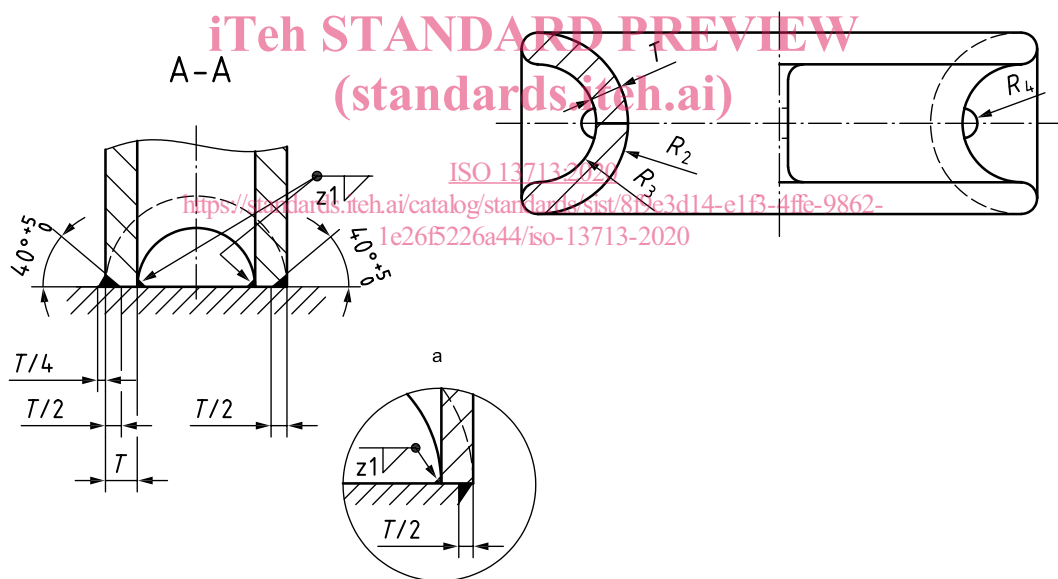
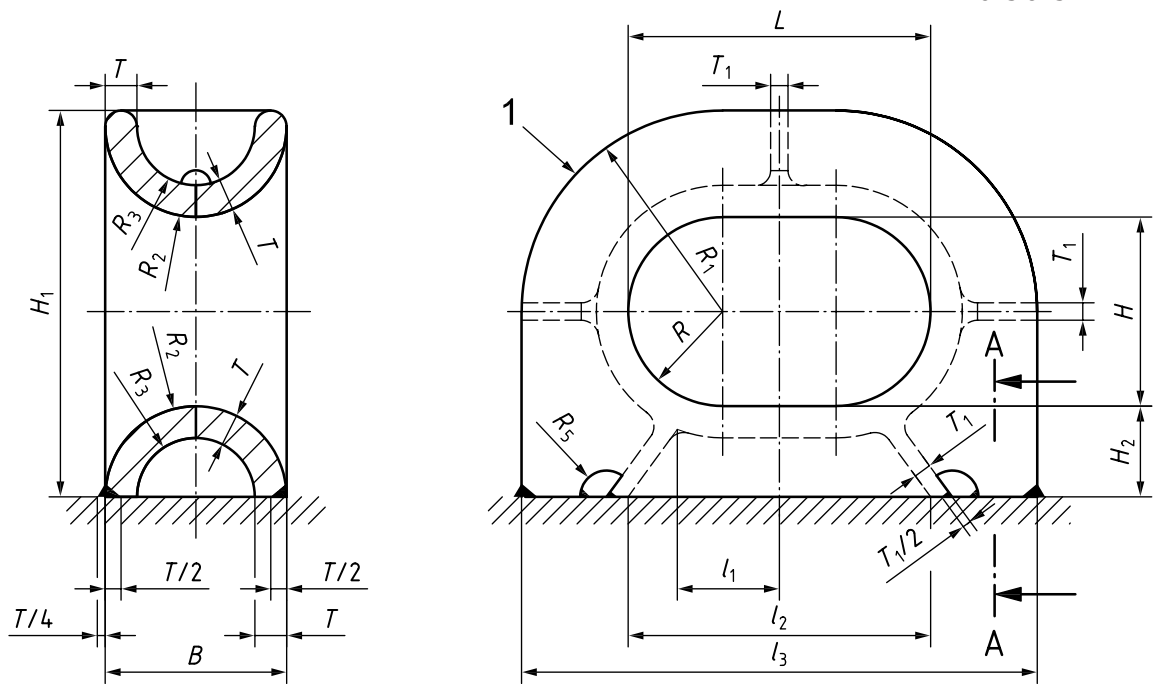

Key

- 1 mooring chock
- a Alternative welding method.

Figure 1 — Type A — Deck-mounted mooring chocks