

---

---

**Ships and marine technology —  
Guardrails for cargo ships**

*Navires et technologie maritime — Garde-corps pour navire de charge*

**iTeh STANDARD PREVIEW**  
**(standards.iteh.ai)**

[ISO 5480:2020](https://standards.iteh.ai/catalog/standards/sist/c8897d24-4332-492c-9fac-f5bbe30a54cf/iso-5480-2020)

<https://standards.iteh.ai/catalog/standards/sist/c8897d24-4332-492c-9fac-f5bbe30a54cf/iso-5480-2020>



## iTeh STANDARD PREVIEW (standards.iteh.ai)

[ISO 5480:2020](https://standards.iteh.ai/catalog/standards/sist/c8897d24-4332-492c-9fac-f5bbe30a54cf/iso-5480-2020)

<https://standards.iteh.ai/catalog/standards/sist/c8897d24-4332-492c-9fac-f5bbe30a54cf/iso-5480-2020>



### **COPYRIGHT PROTECTED DOCUMENT**

© ISO 2020

All rights reserved. Unless otherwise specified, or required in the context of its implementation, no part of this publication may be reproduced or utilized otherwise in any form or by any means, electronic or mechanical, including photocopying, or posting on the internet or an intranet, without prior written permission. Permission can be requested from either ISO at the address below or ISO's member body in the country of the requester.

ISO copyright office  
CP 401 • Ch. de Blandonnet 8  
CH-1214 Vernier, Geneva  
Phone: +41 22 749 01 11  
Fax: +41 22 749 09 47  
Email: [copyright@iso.org](mailto:copyright@iso.org)  
Website: [www.iso.org](http://www.iso.org)

Published in Switzerland

# Contents

	Page
Foreword .....	iv
Introduction .....	v
<b>1 Scope .....</b>	<b>1</b>
<b>2 Normative references .....</b>	<b>1</b>
<b>3 Terms and definitions .....</b>	<b>1</b>
<b>4 Materials .....</b>	<b>2</b>
<b>5 Design, construction and installation .....</b>	<b>2</b>
5.1 Principal dimensions .....	2
5.2 Stanchions .....	2
5.3 Rails .....	2
5.4 Stays .....	3
5.5 Fairlead positions .....	3
<b>6 Quality of manufacture and finish .....</b>	<b>3</b>
<b>Annex A (informative) Summation of section modulus .....</b>	<b>11</b>
<b>Bibliography .....</b>	<b>13</b>

## iTeh STANDARD PREVIEW (standards.iteh.ai)

[ISO 5480:2020](https://standards.iteh.ai/catalog/standards/sist/c8897d24-4332-492c-9fac-f5bbe30a54cf/iso-5480-2020)

<https://standards.iteh.ai/catalog/standards/sist/c8897d24-4332-492c-9fac-f5bbe30a54cf/iso-5480-2020>

## Foreword

ISO (the International Organization for Standardization) is a worldwide federation of national standards bodies (ISO member bodies). The work of preparing International Standards is normally carried out through ISO technical committees. Each member body interested in a subject for which a technical committee has been established has the right to be represented on that committee. International organizations, governmental and non-governmental, in liaison with ISO, also take part in the work. ISO collaborates closely with the International Electrotechnical Commission (IEC) on all matters of electrotechnical standardization.

The procedures used to develop this document and those intended for its further maintenance are described in the ISO/IEC Directives, Part 1. In particular, the different approval criteria needed for the different types of ISO documents should be noted. This document was drafted in accordance with the editorial rules of the ISO/IEC Directives, Part 2 (see [www.iso.org/directives](http://www.iso.org/directives)).

Attention is drawn to the possibility that some of the elements of this document may be the subject of patent rights. ISO shall not be held responsible for identifying any or all such patent rights. Details of any patent rights identified during the development of the document will be in the Introduction and/or on the ISO list of patent declarations received (see [www.iso.org/patents](http://www.iso.org/patents)).

Any trade name used in this document is information given for the convenience of users and does not constitute an endorsement.

For an explanation of the voluntary nature of standards, the meaning of ISO specific terms and expressions related to conformity assessment, as well as information about ISO's adherence to the World Trade Organization (WTO) principles in the Technical Barriers to Trade (TBT), see [www.iso.org/iso/foreword.html](http://www.iso.org/iso/foreword.html).

This document was prepared by Technical Committee ISO/TC 8, *Ships and marine technology*, Subcommittee SC 8, *Ship design*.

This second edition cancels and replaces the first edition (ISO 5480:1979), which has been technically revised.

The main changes compared to the previous edition are as follows:

- the normative references have been updated;
- the diameter of the lower rails and the top rails have been changed;
- the size of the stays has been changed;
- technical advice has been added as the second paragraph in [5.4.1](#);
- the guardrails from [Figure 1](#) to [Figure 4](#) have been editorially amended, and guardrails at multipurpose fairlead in [Figure 4](#) have been updated;
- the summation of section modulus has been added as [Annex A](#).

Any feedback or questions on this document should be directed to the user's national standards body. A complete listing of these bodies can be found at [www.iso.org/members.html](http://www.iso.org/members.html).

## Introduction

Cargo ships meeting the requirements of this document are deemed to comply with the regulations of the International Convention on Loadlines, 1966 Annex 1, Chapter II, Regulation 25, Paragraphs 2 and 3, as amended by the Protocol of 1988.

NOTE Users of this document are understood to be aware of any other statutory requirements, rules and regulations that can be applicable to the individual ships concerned.

## iTeh STANDARD PREVIEW (standards.iteh.ai)

[ISO 5480:2020](https://standards.iteh.ai/catalog/standards/sist/c8897d24-4332-492c-9fac-f5bbe30a54cf/iso-5480-2020)

<https://standards.iteh.ai/catalog/standards/sist/c8897d24-4332-492c-9fac-f5bbe30a54cf/iso-5480-2020>

**iTeh STANDARD PREVIEW**  
**(standards.iteh.ai)**

[ISO 5480:2020](#)

<https://standards.iteh.ai/catalog/standards/sist/c8897d24-4332-492c-9fac-f5bbe30a54cf/iso-5480-2020>

# Ships and marine technology — Guardrails for cargo ships

## 1 Scope

This document specifies dimensions, materials, quality of manufacture and finish for guardrails and stanchions fitted on exposed freeboard and superstructure decks of cargo ships to prevent personnel falling overboard or to lower decks. It is not applicable to guardrails fitted near compasses.

## 2 Normative references

The following documents are referred to in the text in such a way that some or all of their content constitutes requirements of this document. For dated references, only the edition cited applies. For undated references, the latest edition of the referenced document (including any amendments) applies.

ISO 65, *Carbon steel tubes suitable for screwing in accordance with ISO 7-1*

ISO 887, *Plain washers for metric bolts, screws and nuts for general purposes — General plan*

ISO 898-1, *Mechanical properties of fasteners made of carbon steel and alloy steel — Part 1: Bolts, screws and studs with specified property classes — Coarse thread and fine pitch thread*

ISO 1461, *Hot dip galvanized coatings on fabricated iron and steel articles — Specifications and test methods*

## 3 Terms and definitions

For the purposes of this document, the following terms and definitions apply.

ISO and IEC maintain terminological databases for use in standardization at the following addresses:

- ISO Online browsing platform: available at <https://www.iso.org/obp>
- IEC Electropedia: available at <http://www.electropedia.org/>

### 3.1

#### **guardrail**

construction comprising *stanchions* (3.2), *rails* (3.3), *toprails* (3.4) and *stays* (3.5)

Note 1 to entry: See [Figure 1](#) and [Figure 4](#).

### 3.2

#### **stanchion**

principal vertical structural member of a *guardrail* (3.1) system

### 3.3

#### **rail**

horizontal member between *stanchions* (3.2)

### 3.4

#### **toprail**

uppermost *rail* (3.3) in a series of rails

### 3.5

#### **stay**

secondary structural support attached to *stanchions* (3.2) and deck

## 4 Materials

The materials for the manufacture of individual components shall be as specified in [Table 1](#).

**Table 1 — Components and materials of guardrails**

Item No.	Component	Material	Meeting the requirements of:	Remarks
1	stanchions	steel	—	weldable
2	stays	steel	—	weldable
3	toprails, tube	steel	ISO 65	weldable
	toprails, wooden	teak	—	or other suitable hardwood
4	rails	steel	—	weldable
5	washers	brass or steel	ISO 887	—
6	nuts	brass or steel	—	—
7	bolts	steel	ISO 898-1	—
8	screws	brass or steel	—	wood screws

## 5 Design, construction and installation

### 5.1 Principal dimensions

**5.1.1** The height of the toprails shall be at least 1 000 mm. This dimension shall be measured from the top of the toprail to the deck at a point vertically below the inner edge of the toprail, or, if the deck has a waterway, to the top of the deck plank or covering next to the waterway (see [Figure 1](#) and [Figure 2](#)).

**5.1.2** The opening below the lowest course of rails shall be of 230 mm maximum, measured from the underside of the rail to the deck or flat bar side plate where fitted (see [Figure 1](#) and [Figure 2](#)).

**5.1.3** The opening between the upper courses shall be of 380 mm maximum (see [Figure 1](#)).

**5.1.4** The maximum distance between stanchions shall be 1 500 mm [see [Figure 4 a](#)].

### 5.2 Stanchions

Stanchions for guardrails shall be made of steel flat bars of 60 mm × 15 mm, or of flat bars having a section modulus (see ISO 80000-4) at least equal to that of 60 mm × 15 mm flat bars.

### 5.3 Rails

**5.3.1** Steel toprails shall be made of tubes of minimum 34 mm outside diameter, with a wall thickness of at least 2,6 mm, or of tubes having at least an equivalent section modulus, and shall be welded to stanchions.

**5.3.2** Where wooden toprails are required, they shall be 125 mm × 60 mm, made from first quality teak and free from defects such as waness, splits and checks. Other hardwoods may be used provided that they are at least as suitable in all respects.

**5.3.3** Lower rails shall be made of solid round bars of at least 19 mm diameter. As an alternative, tubes of 26,9 mm outside diameter with a wall thickness of at least 2,3 mm, or tubes having at least an equivalent section modulus, may be used. The rails shall be welded to the inside edge of stanchions or passed through holes in the stanchions and welded in position.



## 5.4 Stays

**5.4.1** Stays shall be made of flat bars of 60 mm × 9 mm, or of flat bars having a section modulus at least equal to that of 60 mm × 9 mm flat bars.

**5.4.2** The size and/or section modulus of the stays may be reduced if the sum of the section modulus of the actual stanchions and stays at onboard, by using the calculation method given in [Annex A](#), is greater than the sum of the section modulus specified in [5.2](#) and [5.4.1](#).

**5.4.3** A stay is not needed on every stanchion and shall be fitted depending on the length of the guardrail and the shipboard conditions.

**5.4.4** The stay shall be welded to stanchions at about mid-height and under an angle of approximately 30°.

## 5.5 Fairlead positions

Typical arrangements of guardrails at fairlead positions are shown in [Figure 4](#) for guidance.

## 6 Quality of manufacture and finish

**6.1** Guardrails and stanchions shall be free from any defects and imperfections likely to cause injury to persons using them.

**6.2** The rails, stanchions and stays shall be given protective finishes appropriate to their material and to their shipboard location. If galvanizing is applied, it shall be carried out in accordance with ISO 1461.

<https://standards.iteh.ai/catalog/standards/sist/c8897d24-4332-492c-9fac-f5bbe30a54cf/iso-5480-2020>

Dimensions in millimetres

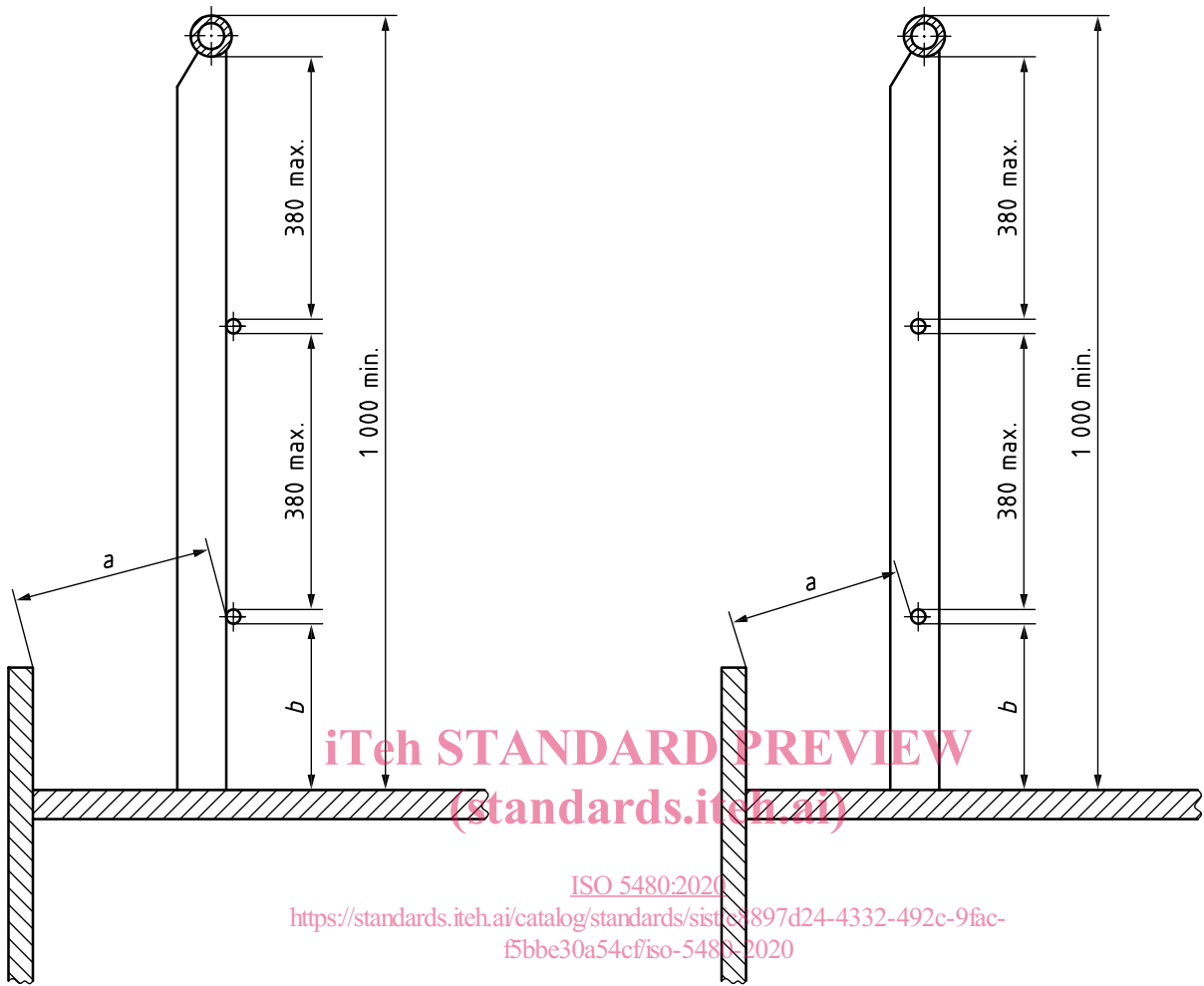

Type S<sub>1</sub>

Type S<sub>2</sub>

**Key**

*a* opening below the lowest course of the guardrail

*b* opening below the lowest course of the guardrail

The openings *a* or *b* below the lowest course of the guardrail shall not exceed 230 mm.

**Figure 1 — Details of rails and stanchions**

Dimensions in millimetres

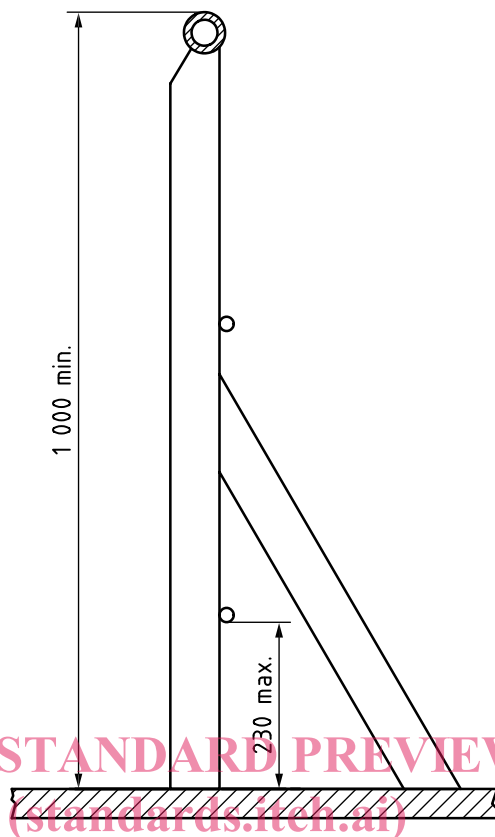

a) Sheer strake arrangement  
(for deck walkway)

<https://standards.iteh.ai/catalog/standards/sist/c8897d24-4332-492c-9fac-f5bbe30a54cf/iso-5480-2020>