



Designation: ~~D2863-09~~ Designation: D2863 - 10

Standard Test Method for Measuring the Minimum Oxygen Concentration to Support Candle-Like Combustion of Plastics (Oxygen Index)¹

This standard is issued under the fixed designation D2863; the number immediately following the designation indicates the year of original adoption or, in the case of revision, the year of last revision. A number in parentheses indicates the year of last reapproval. A superscript epsilon (ϵ) indicates an editorial change since the last revision or reapproval.

This standard has been approved for use by agencies of the Department of Defense.

1. Scope *

1.1 This fire-test-response standard describes a procedure for measuring the minimum concentration of oxygen, expressed as percent volume, that will just support flaming combustion in a flowing mixture of oxygen and nitrogen.

1.2 This test method provides three testing procedures. Procedure A involves top surface ignition, Procedure B involves propagating ignition, and Procedure C is a short procedure involving the comparison with a specified minimum value of the oxygen index.

1.3 Test specimens used for this test method are prepared into one of six types of specimens (see Table 1).

1.4 This test method provides for testing materials that are structurally self-supporting in the form of vertical bars or sheet up to 10.5-mm thick. Such materials are solid, laminated or cellular materials characterized by an apparent density greater than 15 kg/m³.

1.5 This test method also provides for testing flexible sheet or film materials, while supported vertically.

1.6 This test method is also suitable, in some cases, for cellular materials having an apparent density of less than 15 kg/m³.

NOTE 1—Although this test method has been found applicable for testing some other materials, the precision of the test method has not been determined for these materials, or for specimen geometries and test conditions outside those recommended herein.

1.7 This test method measures and describes the response of materials, products, or assemblies to heat and flame under controlled conditions, but does not by itself incorporate all factors required for fire hazard or fire risk assessment of the materials, products, or assemblies under actual fire conditions.

1-8

1.8 The values stated in SI units are to be regarded as standard. No other units of measurement are included in this standard.

1.9 *This standard does not purport to address all of the safety concerns, if any, associated with its use. It is the responsibility of the user of this standard to establish appropriate safety and health practices and determine the applicability of regulatory limitations prior to use.* Specific hazards statement are given in Section 10.

1-9

1.10 *Fire testing is inherently hazardous. Adequate safeguards for personnel and property shall be employed in conducting these tests.*

NOTE 2—This test method and ISO 4589-2 are technically equivalent when using the gas measurement and control device described in 6.3.1, with direct oxygen concentration measurement.

2. Referenced Documents

2.1 ASTM Standards:²

D618 Practice for Conditioning Plastics for Testing

D1071 Test Methods for Volumetric Measurement of Gaseous Fuel Samples

D1622 Test Method for Apparent Density of Rigid Cellular Plastics

D4802 Specification for Poly(Methyl Methacrylate) Acrylic Plastic Sheet

E176 Terminology of Fire Standards

E691 Practice for Conducting an Interlaboratory Study to Determine the Precision of a Test Method

¹ This test method is under the jurisdiction of ASTM Committee D20 on Plastics and is the direct responsibility of Subcommittee D20.30 on Thermal Properties. Current edition approved Sept-Aug. 1, 2009; 2010. Published September 2009; August 2010. Originally approved in 1970. Last previous edition approved in 2008; 2009 as D2863 - 08; 2009. DOI: 10.1520/D2863-10.9.

² For referenced ASTM standards, visit the ASTM website, www.astm.org, or contact ASTM Customer Service at service@astm.org. For Annual Book of ASTM Standards volume information, refer to the standard's Document Summary page on the ASTM website.

*A Summary of Changes section appears at the end of this standard.

TABLE 1 Test Specimen Dimensions

Test Specimen Type ^A	Dimensions			Material Form
	Length, mm	Width, mm	Thickness, mm	
I	80 to 150	10 ± 0.5	4 ± 0.25	for molding materials
II	80 to 150	10 ± 0.5	10 ± 0.5	for cellular materials
III ^B	80 to 150	10 ± 0.5	≤ 10.5	for sheet materials
IV ^C	70 to 150	6.5 ± 0.5	3 ± 0.25	alternative size for self-supporting molding or sheet materials
V ^B	140 ± 5	52 ± 0.5	≤ 10.5	for flexible film or sheet
VI ^{BD}	140 to 200	20	0.02 to 0.10	for thin film; limited to film that can be rolled by the wire specified in 6.7

^A Test specimens of Types I, II, III, and IV are suitable for materials that are self-supporting at these dimensions. Test specimens of Form V and VI are suitable for materials that require support during testing. Test specimens of Form VI are suitable for film materials that can be rolled into a self-supporting specimen by the procedure in 7.4.

^B Compare results obtained using Type III, V, and VI test specimens only to those obtained using specimens of the same form and thickness. It is assumed that the amount of variation in thickness for such materials will be controlled by other standards.

^C The Type IV (ASTM) specimen will eventually be discontinued in favor of the Type 1 (ISO) specimen.

^D The test specimen of Type VI is suitable for thin film that is self-supporting when it is rolled (see 7.4). Dimensions in the table are of the specimen size from which the rolled form is made. If the film is very thin, it is possible that proper results will only be obtained if two or more layers are combined in the preparation of the roll to obtain proper results.

2.2 ISO Standards:³

ISO 4589-2 Plastics—Determination of Flammability by Oxygen Index—Part 2, Ambient Temperatures

ISO 7823-1 Poly(Methylmethacrylate) Sheets—Types, Dimensions and Characteristics—Part 1—Cast Sheets

ISO 13943 Fire Safety—Vocabulary

3. Terminology

3.1 Definitions

3.1.1 For definitions of terms used in this test method refer to the terminology contained in Terminology E176 and ISO 13943.

In case of conflict, the definitions given in Terminology E176 shall prevail.

3.2 *Definitions: Definitions Specific to This Standard:*

3.2.1 *ignition*—the initiation of combustion.

3.2.2 *oxygen index (OI)*—the minimum concentration of oxygen determined by the method in 12.1, expressed as volume percent, in a mixture of oxygen and nitrogen that will just support flaming combustion of a material initially at 23 ± 2°C under the conditions of this test method.

3.3 Symbols Specific To This Test Method:

3.3.1 C_o —oxygen concentration in percent volume.

3.3.2 C_F —final value of oxygen concentration in percent volume.

3.3.3 C_i —each of the oxygen concentration percentages used during measurement of the last six responses in the N_T series.

3.3.4 O —neither the period or extent of burning exceeds the relevant limit specified in Table 2.

3.3.5 X —the period or extent of burning exceeds the relevant limit specified in Table 2.

3.3.6 N_L —series of “X” or “O” results.

3.3.7 N_T —series of “X” or “O” results plus five ($N_T = N_L + 5$).

3.3.8 σ^* —standard deviation of the oxygen concentration.

3.3.9 d —interval between oxygen concentration levels in percent volume.

3.3.10 k —a factor to be determined from Table 3.

3.3.11 n —number of measurements of oxygen concentration.

4. Summary of Test Method

4.1 A small test specimen is supported vertically in a mixture of oxygen and nitrogen flowing upwards through a transparent chimney. The upper end of the specimen is ignited and the subsequent burning behavior of the specimen is observed to compare

³ Available from American National Standards Institute (ANSI), 25 W. 43rd St., 4th Floor, New York, NY 10036, <http://www.ansi.org>.

TABLE 2 Criteria for Oxygen Index Measurements^A

Test Specimen Type (See Table 1)	Ignition Procedure	Alternative Criteria	
		Period of Burning After Ignition(s)	Extent of Burning ^B
I, II, III, IV, and VI	A (top surface ignition)	180	50 mm below the top of the specimen
I, II, III, IV, and VI	B (propagating ignition)	180	50 mm below the upper reference mark
V	propagating ignition	180	80 mm below the upper reference mark (on the frame)

^A These criteria do not necessarily produce equivalent oxygen index results for specimens of differing shape or tested using different ignition conditions or procedures.

^B The extent of burning is exceeded when any part of the visibly burning portion of a specimen, including burning drips descending the vertical faces, passes the level indicated in the column.

TABLE 3 Determination of *k*

1	2	3	4	5	6
Responses for the Last Five Measurements	Values of <i>k</i> for which the first <i>N_L</i> determinations are:				Responses for the Last Five Measurements ^A
	(a) O	OO	OOO	OOOO	
XOOOO	-0.55	-0.55	-0.55	-0.55	OXXXX
XOOOX	-1.25	-1.25	-1.25	-1.25	OXXOX
XOOXO	0.37	0.38	0.38	0.38	OXXOX
XOXXX	-0.17	-0.14	-0.14	-0.14	OXXOO
XOXOO	0.02	0.04	0.04	0.04	OXOXX
XOXOX	-0.50	-0.46	-0.45	-0.45	OXOXO
XOXXO	1.17	1.24	1.25	1.25	OXOXO
XOXXX	0.61	0.73	0.76	0.76	OXOOO
XXOOO	-0.30	-0.27	-0.26	-0.26	OXXXX
XXOOX	-0.83	-0.76	-0.75	-0.75	OXXOX
XXOXO	0.83	0.94	0.95	0.95	OXXOX
XXOXX	0.30	0.46	0.50	0.50	OXXOO
XXXOO	0.50	0.65	0.68	0.68	OXXXX
XXXOX	-0.04	0.19	0.24	0.25	OXXOX
XXXO	1.60	1.92	2.00	2.01	OXXXX
XXXXX	0.89	1.33	1.47	1.50	OXXXX

^A Values of *k* for which the first *N_L* determinations are (b) X, XX, XXX, and XXXX are as given in Table 3 opposite the appropriate response in Column 6, but with the sign of *k* reversed, that is: $OI = C_F - kd$ (see 12.1).

the period for which burning continues, or the length of specimen burnt, with specified limits for each burning. By testing a series of specimens in different oxygen concentrations, the minimum oxygen concentration is determined.

4.2 Three procedures are included in this test method. In Procedure A, a complete assessment of the oxygen index is conducted using top surface ignition. In Procedure B, a complete assessment of the oxygen index is conducted using propagating ignition. Procedure C provides a comparison with a specified minimum value of oxygen index and can be conducted using top surface ignition or propagating ignition.

5. Significance and Use

5.1 This test method provides for the measuring of the minimum concentration of oxygen in a flowing mixture of oxygen and nitrogen that will just support flaming combustion of plastics. Correlation with burning characteristics under actual use conditions is not implied.

5.2 In this test method, the specimens are subjected to one or more specific sets of laboratory test conditions. If different test conditions are substituted or the end-use conditions are changed, it is not always possible by or from this test to predict changes in the fire-test-response characteristics measured. Therefore, the results are valid only for the fire-test-exposure conditions described in this test method.

6. Apparatus

6.1 *Test Chimney.* The test chimney consists of a heat-resistant glass tube of 75 to 100-mm inside diameter and 450 to 500-mm height. The opening at the top of the chimney shall be restricted to provide an outlet of 40 ± 2 -mm diameter, either by providing an overhead cap or by designing the glass chimney appropriately. The bottom of the chimney, or the base to which the tube is attached, shall contain noncombustible material to evenly mix and distribute the gas mixture entering at this base. Glass beads 3 to 5 mm in diameter in a bed 80 to 100-mm deep have been found suitable. The chimney shall be mounted securely on the base to prevent air leaks. One example of a design is shown in Fig. 1.

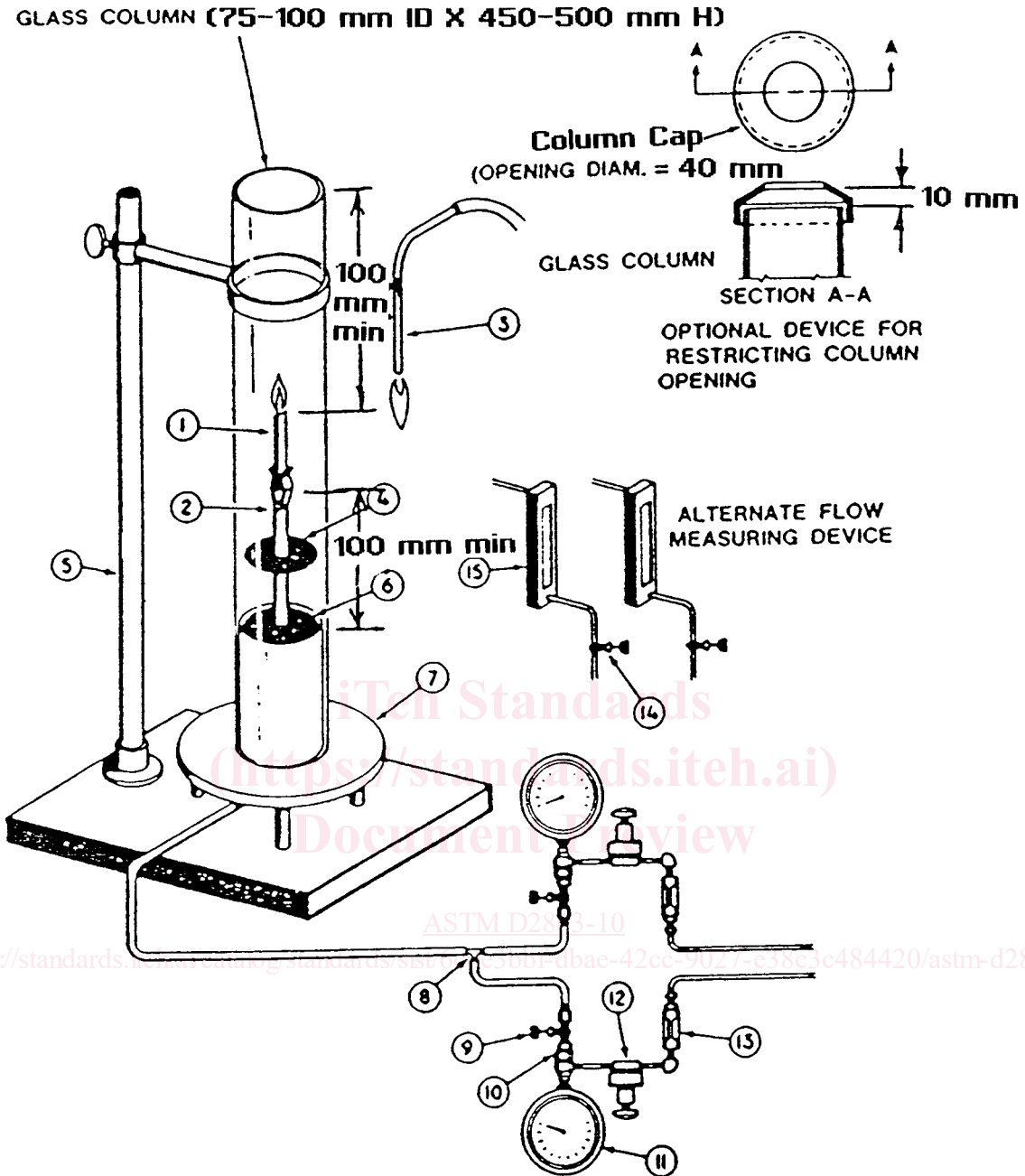

- 1. Burning Specimen
- 2. Clamp with Rod Support
- 3. Igniter
- 4. Wire Screen
- 5. Ring Stand

- 6. Glass Beads in a Bed
- 7. Brass Base
- 8. Tee
- 9. Cut-Off Valve
- 10. Orifice in Holder

- 11. Pressure Gauge
- 12. Precision Pressure Regulator
- 13. Filter
- 14. Needle Valve
- 15. Rotameter

FIG. 1 Typical Equipment Layout

NOTE 3—It is helpful to place a wire screen above the noncombustible material to catch falling fragments and to aid in keeping the base of the column clean.

6.2 Specimen Holders

6.2.1 *Specimen Holder for Self-Supporting Specimens*—Any small holding device that will support the specimen at its base and hold it vertically in the center of the chimney is an acceptable specimen holder. A typical arrangement (see Fig. 1) consists of a laboratory thermometer clamp inserted into the end of a glass tube held in place by glass beads or otherwise firmly supported.

6.2.2 *Specimen Holder for Specimens of Flexible Sheet or Film Materials that Require Support*—A specimen holder for flexible film or sheet materials that require support shall be able to support the specimen by both vertical edges in a frame equivalent to

that illustrated by Fig. 2, with reference marks at 20 and 100 mm below the top of the frame. The profile of the holder and its support shall be smooth to minimize induction of turbulence in the rising flow of gas.

6.2.3 *Thin Film Rolling Tool*—In order to prepare self-supporting specimens from thin films (see 7.4), use a 2 ± 0.1 -mm stainless steel rod with a 0.3 ± 0.05 -mm slit at one end, equivalent to that illustrated in Fig. 3. The actual specimen holder shall be the one in 6.2.1.

6.3 *Gas Measurement and Control Devices*. Gas measurement and control devices shall be suitable for measuring the concentration of oxygen in the gas mixture entering the chimney with an accuracy of ± 0.5 %, by volume, of the gas mixture and for adjusting the concentration of oxygen in the mixture with a precision of ± 0.1 %, by volume, of the gas mixture, when the gas velocity through the chimney is 40 ± 2 mm/s at $23 \pm 2^\circ\text{C}$.

6.3.1 A typical system for gas measurement and control involves needle valves on individual and mixed gas supply lines, a paramagnetic oxygen analyzer that continuously samples the mixed gas, and a flowmeter to indicate when the gas flow through the chimney is within the required limits.

6.3.2 An alternative system of measurement and control does not use direct oxygen concentration measurements, but has proved satisfactory. It includes the following: calibrated orifices, gas pressure regulators, and pressure gauges on the individual gas supply lines and needle valves and calibrated flowmeters on the individual gas supply lines.

6.3.3 Any system used requires calibration after assembly to ensure that the compounded errors of the component parts do not exceed the requirements of 6.3.

6.3.4 Means shall be provided for checking or ensuring that the temperature of the gas mixture entering the chimney is $23 \pm 2^\circ\text{C}$. If this involves an internal probe, its position and profile shall be designed to minimize induction of turbulence within the chimney.

6.4 *Flame Igniter*. The flame igniter shall comprise a tube, with an inside diameter of 2 ± 1 mm, that can be inserted into the chimney to apply the test flame.

6.4.1 The flame fuel shall be methane or natural gas of at least 97 % purity, without premixed air. The fuel supply shall be adjusted so that the flame projects 16 ± 4 mm vertically downwards from the outlet when the tube is vertical within the chimney and the flame is burning within the chimney atmosphere.

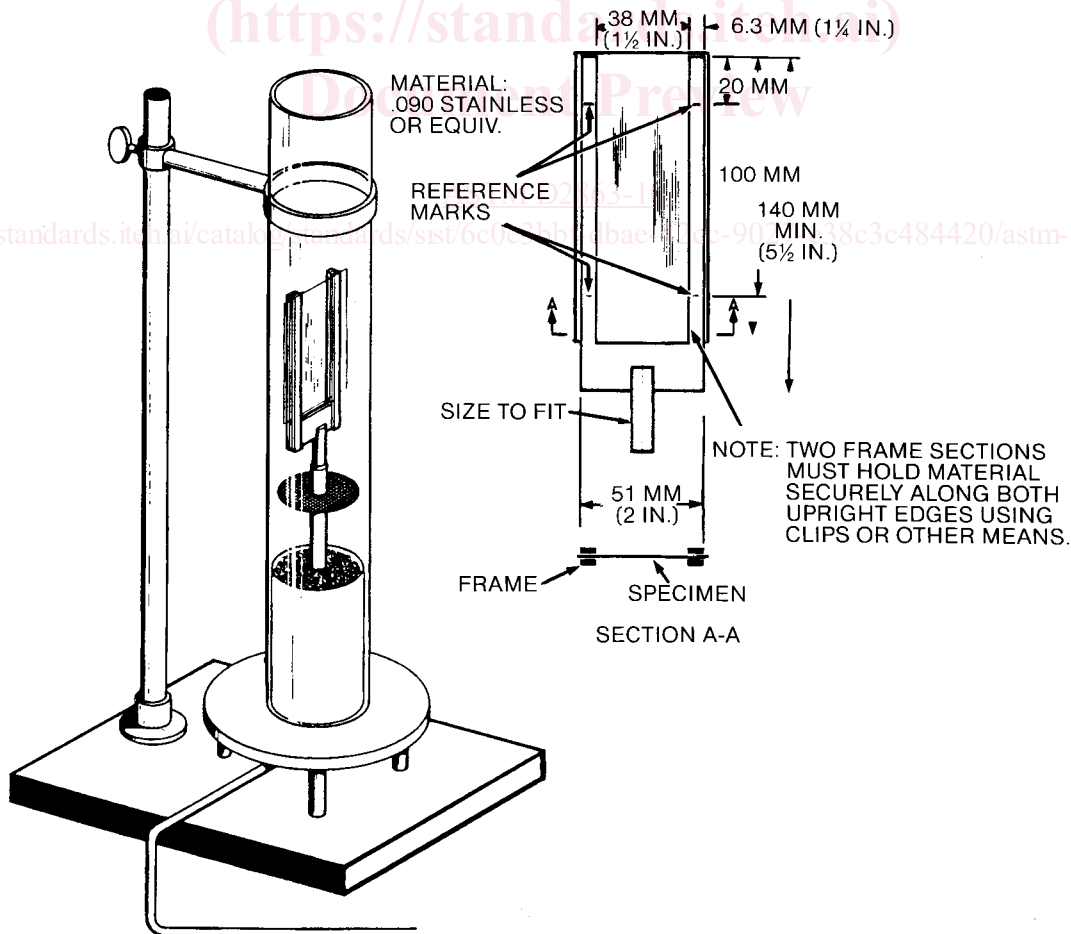

FIG. 2 Frame Design

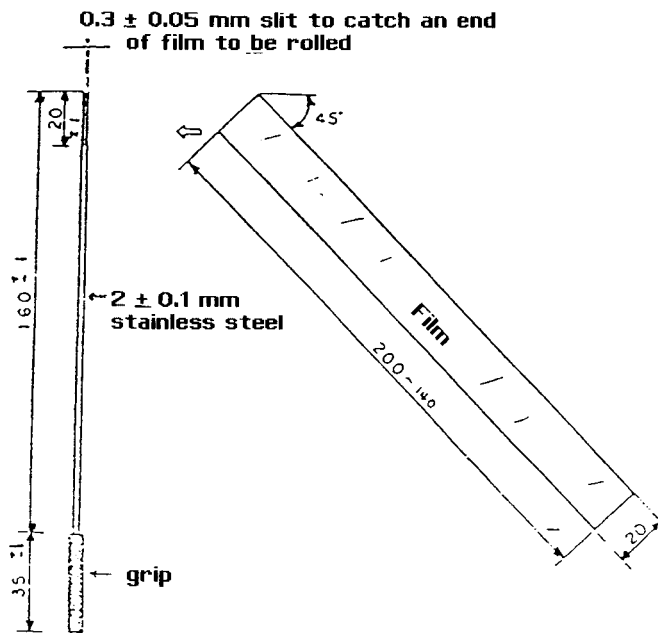

FIG. 3 Rod with a Slit

6.5 *Timing Device.* A timing device shall be provided, which is capable of measuring periods up to 5 min with an accuracy of ± 0.5 s.

6.6 *Fume Extraction System.* A fume extraction system shall be provided with sufficient ventilation or exhaust to remove fumes or soot expelled from the chimney without disrupting the gas-flow rate or temperatures in the chimney.

NOTE 4—If soot-generating materials are being tested, it is likely that the glass chimney, gas inlets, and inlet screen will require cleaning between tests to maintain good visibility and to function properly.

6.7 *Gas Supplies.* The gas supplied to the test apparatus shall consist of pressurized sources of oxygen or nitrogen, or both, not less than 98 % pure or clean dry air, or both, (containing 20.9 % oxygen), as appropriate.

6.7.1 The gas mixture entering the chimney shall have a moisture content of < 0.1 %, unless the results have been shown to be insensitive to higher moisture levels in the gas mixture. The gas supply system shall incorporate a drying device, or provision for monitoring or sampling the gas supply for moisture content, unless the moisture content of the gas supplies is known to be acceptable.

NOTE 5—It must be noted that bottled oxygen or nitrogen will not always contain < 0.1 % of water; moisture contents of 0.003 to 0.01 % are typical for commercial supplies as filled bottles > 98 % pure, but as such bottled gases are depressured to below about 1 MPa, the moisture content of the gas drawn off has been found to rise above 0.1 %.

7. Test Specimens

7.1 General.

7.1.1 The specimens shall be die-punched, cut by hand using a razor blade or other sharp tool, or cut by an automatic machine. Alternatively, specimens shall be prepared directly by injection molding.

7.1.2 Ensure that the surfaces of the specimens are clean and free from flaws that could affect burning behavior, for example, peripheral molding flash or burrs from machining. The edges of the specimens shall be smooth and free from fuzz or burrs of material left from machining or molding.

7.1.3 Record the position and orientation of the test specimens with respect to any asymmetry in the sample material (see Note 6).

NOTE 6—Oxygen index results are likely to be significantly affected by differences in burning behavior, due to material inhomogeneity (for example, different levels of shrinkage when heated for specimens cut in different directions from asymmetrically-oriented thermoplastics film).

7.1.4 The test specimens shall conform to the dimensions and geometry listed in Table 3. If non-standard size specimens are used, a difference in oxygen index is likely to result.

7.1.5 It is likely that, for materials where the oxygen index is known to within ± 2 % by volume, 15 test specimens will be sufficient. However, for materials of unknown oxygen index, or which exhibit erratic burning characteristics, between 15 and 30 test specimens are likely to be required.

7.2 Self-Supporting Specimens (Specimen Types I, II, III, and IV)

7.2.1 The specimens shall be prepared in accordance with 7.1.