

---

---

**Machinery for forestry — Portable  
chain-saw safety requirements and  
testing —**

**Part 1:  
Chain-saws for forest service**

*Matériel forestier — Exigences de sécurité et essais des scies à chaîne  
portatives —*

*Partie 1: Scies à chaîne pour travaux forestiers*

ISO 11681-1:2022

<https://standards.iteh.ai/catalog/standards/sist/21b7e16d-b696-4112-a2b9-69f67ad24854/iso-11681-1-2022>



iTeh STANDARD PREVIEW  
(standards.iteh.ai)

ISO 11681-1:2022

<https://standards.iteh.ai/catalog/standards/sist/21b7e16d-b696-4112-a2b9-69f67ad24854/iso-11681-1-2022>



**COPYRIGHT PROTECTED DOCUMENT**

© ISO 2022

All rights reserved. Unless otherwise specified, or required in the context of its implementation, no part of this publication may be reproduced or utilized otherwise in any form or by any means, electronic or mechanical, including photocopying, or posting on the internet or an intranet, without prior written permission. Permission can be requested from either ISO at the address below or ISO's member body in the country of the requester.

ISO copyright office  
CP 401 • Ch. de Blandonnet 8  
CH-1214 Vernier, Geneva  
Phone: +41 22 749 01 11  
Email: [copyright@iso.org](mailto:copyright@iso.org)  
Website: [www.iso.org](http://www.iso.org)

Published in Switzerland

# Contents

	Page
Foreword.....	v
Introduction.....	vi
<b>1 Scope.....</b>	<b>1</b>
<b>2 Normative references.....</b>	<b>2</b>
<b>3 Terms and definitions.....</b>	<b>3</b>
<b>4 Safety requirements and/or protective measures.....</b>	<b>3</b>
4.1 General.....	3
4.2 Handles.....	3
4.2.1 Requirements.....	3
4.2.2 Verification.....	3
4.3 Hand protection.....	4
4.3.1 Protection at front handle.....	4
4.3.2 Protection at the rear handle.....	4
4.4 Balance.....	5
4.4.1 Requirements.....	5
4.4.2 Verification.....	5
4.5 Protection against injury by kickback.....	5
4.5.1 Chain brake.....	5
4.5.2 Non-manual chain brake.....	6
4.5.3 Kickback and chain stop angles.....	6
4.6 Chain catcher.....	6
4.6.1 Requirements.....	6
4.6.2 Verification.....	6
4.7 Spiked bumper.....	6
4.7.1 Requirements.....	6
4.7.2 Verification.....	6
4.8 Chip discharge.....	7
4.8.1 Requirements.....	7
4.8.2 Verification.....	7
4.9 Guide bar cover.....	7
4.9.1 Requirements.....	7
4.9.2 Verification.....	7
4.10 Engine starting device.....	7
4.10.1 Requirements.....	7
4.10.2 Verification.....	7
4.11 Engine stopping device.....	7
4.11.1 Requirements.....	7
4.11.2 Verification.....	7
4.12 Throttle control system.....	8
4.12.1 Dimensions.....	8
4.12.2 Operation.....	8
4.12.3 Throttle control latch.....	9
4.13 Drive sprocket guard.....	10
4.13.1 Requirements.....	10
4.13.2 Verification.....	10
4.14 Clutch.....	11
4.14.1 Requirements.....	11
4.14.2 Verification.....	11
4.15 Protection against contact with parts under high voltage.....	11
4.15.1 Requirements.....	11
4.15.2 Verification.....	11
4.16 Protection against contact with hot parts.....	11
4.16.1 Requirements.....	11

4.16.2	Verification	13
4.17	Fuel and oil systems	14
4.17.1	Requirements	14
4.17.2	Verification	14
4.18	Exhaust gases	15
4.18.1	Requirements	15
4.18.2	Verification	15
4.19	Chain lubrication	15
4.19.1	Requirements	15
4.19.2	Verification	16
4.20	Chain tensioning	16
4.20.1	Requirements	16
4.20.2	Verification	16
4.21	Vibration	16
4.21.1	Reduction by design at source and by protective measures	16
4.21.2	Vibration measurement	16
4.22	Noise	16
4.22.1	Reduction by design at source and by protective measures	16
4.22.2	Noise measurement	17
4.23	Electromagnetic immunity	17
4.23.1	Requirements	17
4.23.2	Verification	17
<b>5</b>	<b>Information for use</b>	<b>17</b>
5.1	Instructions	17
5.1.1	General	17
5.1.2	Technical data	17
5.1.3	Other information	18
5.2	Marking	20
5.3	Warnings	21
5.4	Test of labels	21
5.4.1	Preparation of test specimens and control specimens	21
5.4.2	Wipe resistance test	22
5.4.3	Adhesion test	22
	<b>Annex A (informative) List of significant hazards</b>	<b>23</b>
	<b>Bibliography</b>	<b>25</b>

## Foreword

ISO (the International Organization for Standardization) is a worldwide federation of national standards bodies (ISO member bodies). The work of preparing International Standards is normally carried out through ISO technical committees. Each member body interested in a subject for which a technical committee has been established has the right to be represented on that committee. International organizations, governmental and non-governmental, in liaison with ISO, also take part in the work. ISO collaborates closely with the International Electrotechnical Commission (IEC) on all matters of electrotechnical standardization.

The procedures used to develop this document and those intended for its further maintenance are described in the ISO/IEC Directives, Part 1. In particular, the different approval criteria needed for the different types of ISO documents should be noted. This document was drafted in accordance with the editorial rules of the ISO/IEC Directives, Part 2 (see [www.iso.org/directives](http://www.iso.org/directives)).

Attention is drawn to the possibility that some of the elements of this document may be the subject of patent rights. ISO shall not be held responsible for identifying any or all such patent rights. Details of any patent rights identified during the development of the document will be in the Introduction and/or on the ISO list of patent declarations received (see [www.iso.org/patents](http://www.iso.org/patents)).

Any trade name used in this document is information given for the convenience of users and does not constitute an endorsement.

For an explanation of the voluntary nature of standards, the meaning of ISO specific terms and expressions related to conformity assessment, as well as information about ISO's adherence to the World Trade Organization (WTO) principles in the Technical Barriers to Trade (TBT), see [www.iso.org/iso/foreword.html](http://www.iso.org/iso/foreword.html).

This document was prepared by Technical Committee ISO/TC 23, *Tractors and machinery for agriculture and forestry*, Subcommittee SC 17, *Manually portable (hand-held) powered lawn and garden equipment and forest machinery*, in collaboration with the European Committee for Standardization (CEN) Technical Committee CEN/TC 144, *Tractors and machinery for agriculture and forestry*, in accordance with the Agreement on technical cooperation between ISO and CEN (Vienna Agreement).

This fourth edition cancels and replaces the third edition (ISO 11681-1:2011), which has been technically revised.

The main changes compared to the previous edition are as follows:

- the normative references in [Clause 2](#) have been updated;
- requirements for kickback in [4.5.3.1](#) have been clarified;
- requirements and verification for throttle control system in [4.12](#) have been updated;
- a new subclause, [4.17.2.3](#) “Fuel feed lines strength and accessibility” has been added;
- [5.1.2](#) “Technical data”, has been updated;
- in [5.1.3](#), information on safe starting procedure has been added.

A list of all parts in the ISO 11681 series can be found on the ISO website.

Any feedback or questions on this document should be directed to the user's national standards body. A complete listing of these bodies can be found at [www.iso.org/members.html](http://www.iso.org/members.html).

## Introduction

This document is a type-C standard as stated in ISO 12100:2010.

This document is of relevance, in particular, for the following stakeholder groups representing the market players with regard to machinery safety: players with regard to machinery safety:

- machine manufacturers (small, medium and large enterprises);
- health and safety bodies (regulators, accident prevention organizations, market surveillance, etc.).

Others can be affected by the level of machinery safety achieved with the means of the document by the above-mentioned stakeholder groups:

- machine users/employers (small, medium and large enterprises);
- machine users/employees (e.g. trade unions, organizations for people with special needs);
- service providers, e.g. for maintenance (small, medium and large enterprises);
- consumers (in case of machinery intended for use by consumers).

The above-mentioned stakeholder groups have been given the possibility to participate at the drafting process of this document.

The machinery concerned and the extent to which hazards, hazardous situations or hazardous events are covered are indicated in the scope of this document.

When requirements of this type-C standard are different from those which are stated in type-A or type-B standards, the requirements of this type-C standard take precedence over the requirements of the other standards for machines that have been designed and built according to the requirements of this type-C standard.

<https://standards.iteh.ai/catalog/standards/sist/21b7e16d-b696-4112-a2b9-69f67ad24854/iso-11681-1-2022>

# Machinery for forestry — Portable chain-saw safety requirements and testing —

## Part 1: Chain-saws for forest service

### 1 Scope

This document specifies safety requirements and measures for verification for the design, construction, transporting and commissioning of portable, combustion-engine, hand-held chain-saws. The chain-saws are intended to be used for forest work by only one operator, with the right hand on the rear handle and left hand on the front handle.

Dismantling and scrapping of the product is not covered by this document. Methods for the elimination or reduction of hazards arising from the use of these machines and the type of information on safe working practices to be provided by the manufacturer are specified.

This document deals with all significant hazards, hazardous situations and hazardous events, with the exception of kickback and balance for machines with an engine displacement of more than 80 cm<sup>3</sup>, relevant to these machines when they are used as intended and under conditions of misuse which are reasonably foreseeable by the manufacturer (see [Annex A](#)).

This document is applicable to chain-saws manufactured after its date of publication.

NOTE [Figure 1](#) shows an example of a chain-saw within the scope of this document.

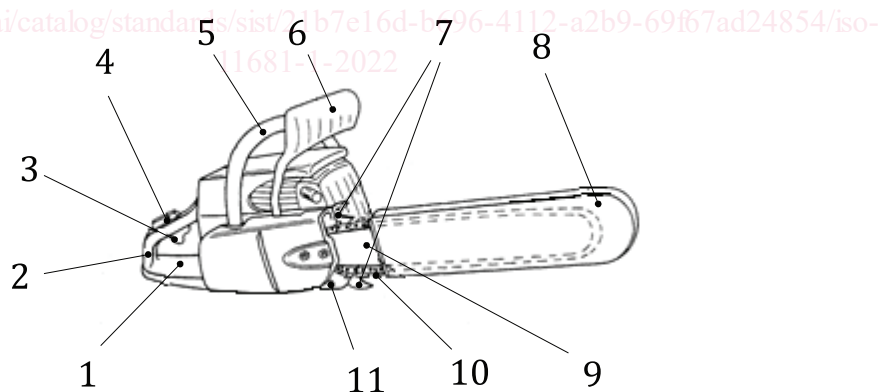

#### Key

1	rear hand-guard	7	spiked bumper
2	rear handle	8	guide-bar cover
3	throttle trigger	9	guide-bar
4	throttle trigger lock-out	10	saw-chain
5	front handle	11	chain catcher
6	front hand-guard		

**Figure 1 — Example of chain-saw**

## 2 Normative references

The following documents are referred to in the text in such a way that some or all of their content constitutes requirements of this document. For dated references, only the edition cited applies. For undated references, the latest edition of the referenced document (including any amendments) applies.

ISO 6531:2017, *Machinery for forestry — Portable chain-saws — Vocabulary*

ISO 6533:2020, *Forestry machinery — Portable chain-saw front hand-guard — Dimensions and clearances*

ISO 6534:2007, *Forestry machinery — Portable chain-saw hand-guards — Mechanical strength*

ISO 6534:2007/Amd 1:2012, *Forestry machinery — Portable chain-saw hand-guards — Mechanical strength — Amendment 1*

ISO 6535:2015, *Portable chain-saws — Chain brake performance*

ISO 7293:2021, *Forestry machinery — Portable chain saws — Engine performance and fuel consumption*

ISO 7914:2002, *Forestry machinery — Portable chain-saws — Minimum handle clearance and sizes*

ISO 7914:2002/Amd 1:2012, *Forestry machinery — Portable chain-saws — Minimum handle clearance and sizes — Amendment 1*

ISO 7915:2021, *Forestry machinery — Portable chain-saws — Determination of handle strength*

ISO 8334:2007, *Forestry machinery — Portable chain-saws — Determination of balance and maximum holding moment*

ISO 9518:2018, *Forestry machinery — Portable chain-saws — Kickback test*

ISO 10726:2020, *Portable chain-saws — Chain catcher — Dimensions and mechanical strength*

ISO 12100:2010, *Safety of machinery — General principles for design — Risk assessment and risk reduction*

ISO 13772:2018, *Forestry machinery — Portable chain-saws — Non-manually actuated chain brake performance*

ISO 13772:2018/Amd 1:2020, *Forestry machinery — Portable chain-saws — Non-manually actuated chain brake performance — Amendment 1*

ISO 13849-1:2015, *Safety of machinery — Safety-related parts of control systems — Part 1: General principles for design*

ISO 13849-2:2012, *Safety of machinery — Safety-related parts of control systems — Part 2: Validation*

ISO 13857:2019, *Safety of machinery — Safety distances to prevent hazard zones being reached by upper and lower limbs*

ISO 14982:1998, *Agricultural and forestry machinery — Electromagnetic compatibility — Test methods and acceptance criteria*

ISO 22867:2021, *Forestry and gardening machinery — Vibration test code for portable hand-held machines with internal combustion engine — Vibration at the handles*

ISO 22868:2021, *Forestry and gardening machinery — Noise test code for portable hand-held machines with internal combustion engine — Engineering method (Grade 2 accuracy)*

IEC 61032:1997, *Protection of persons and equipment by enclosures — Probes for verification*



### 3 Terms and definitions

For the purposes of this document, the terms and definitions given in ISO 6531:2017 and ISO 12100:2010 apply.

ISO and IEC maintain terminological databases for use in standardization at the following addresses:

- ISO Online browsing platform: available at <https://www.iso.org/obp>
- IEC Electropedia: available at <https://www.electropedia.org/>

### 4 Safety requirements and/or protective measures

#### 4.1 General

Machines shall comply with the safety requirements and/or protective measures of this clause. In addition, the machine shall be designed according to the principles of ISO 12100:2010 for relevant but not significant hazards which are not dealt with by this document.

The safe operation of a chain-saw also depends on the safe environment associated with the use of personal protective equipment (PPE), such as gloves, slip-resistant footwear, and leg, eye, foot, hearing and head protective equipment, as well as safe working procedures (see [5.1](#)).

Except where otherwise specified in this document, the safety distances specified in ISO 13857:2019, 4.2.4.1 and 4.2.4.3, shall be met.

#### 4.2 Handles

##### 4.2.1 Requirements

Chain-saws shall have a handle for each hand. These handles shall be designed such that:

- they can be fully gripped by an operator wearing protective gloves,
- they provide the necessary sureness of grip by their shaping and surface,
- they conform to the dimensions and clearances given in ISO 7914:2002 (see also [4.12.1](#)), and
- the strength of both handles complies with ISO 7915:2021.

Chain-saws having a system for isolating machine vibration from the handles shall be designed so that the operator is able to stop the engine in a controlled manner with the engine stopping device (see [4.11](#)), even in the case of failure of the vibration isolation system.

##### 4.2.2 Verification

Dimensions shall be verified by measurement. Strength requirements shall be verified by testing in accordance with ISO 7915:2021. The possibility of stopping the chain-saw engine when a failure has occurred in the vibration isolation system shall be verified by inspection of the design and by functional testing.

## 4.3 Hand protection

### 4.3.1 Protection at front handle

#### 4.3.1.1 Requirements

A hand-guard shall be fitted in the vicinity of the front handle to protect the operator's fingers and hand from injury through contact with the saw-chain.

The dimensions of this front hand-guard shall comply with ISO 6533:2020. Its strength shall comply with ISO 6534:2007.

#### 4.3.1.2 Verification

Dimensions shall be verified by measurement. Strength requirements shall be verified by testing in accordance with ISO 6534:2007.

### 4.3.2 Protection at the rear handle

#### 4.3.2.1 Requirements

A hand-guard shall be provided along the length of the right side of the bottom of the rear handle to protect the operator's hand from contact with a broken saw-chain.

This hand-guard shall extend from the right edge of the handle for at least 30 mm on the guide bar side (see [Figure 2](#)) and

- at least 100 mm lengthwise from the inner rear part of the saw body (see [Figure 2](#)), or
- at least three times the diameter of 25 mm behind the throttle trigger, as defined by three cylinders pressed together against the handle and the throttle trigger, whichever of these options is further back.

This requirement may also be fulfilled by parts of the machine.

The strength of the rear hand-guard shall comply with ISO 6534:2007.

#### 4.3.2.2 Verification

Dimensions shall be verified by measurement. Strength requirements shall be verified by testing in accordance with ISO 6534:2007.

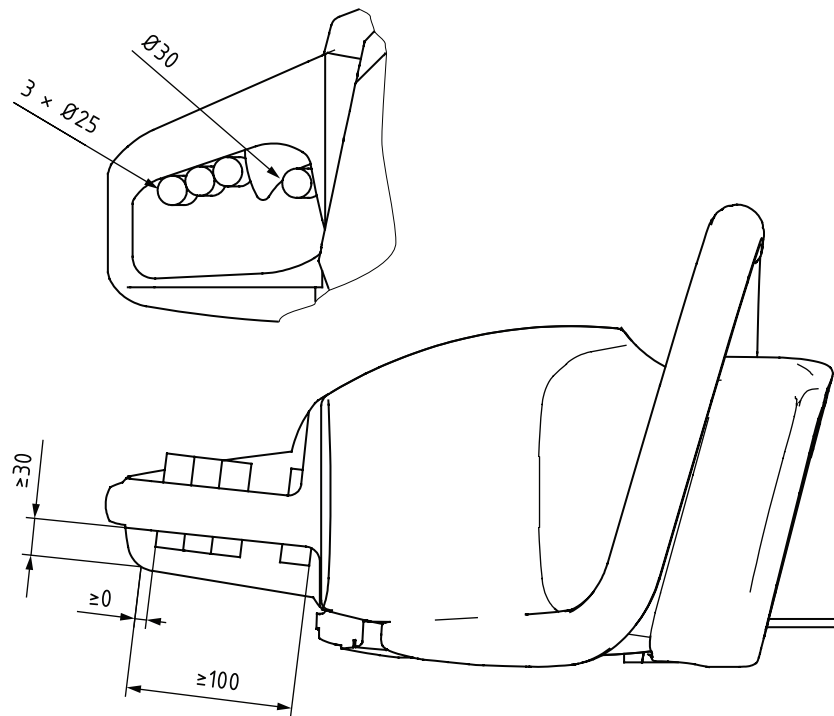

Figure 2 — Minimum dimensions of protection at the rear handle

## 4.4 Balance

### 4.4.1 Requirements

Chain-saws with an engine displacement of 80 cm<sup>3</sup> or less shall be longitudinally balanced to within  $\pm 30^\circ$  between the centreline of the guide bar and the horizontal plane.

The limit shall be met by the shortest and longest applicable guide bars.

NOTE Sufficient information to allow the setting of a limit is not available for chain-saws with an engine displacement of more than 80 cm<sup>3</sup>.

### 4.4.2 Verification

The angle for longitudinal balance shall be verified by functional testing in accordance with ISO 8334:2007.

## 4.5 Protection against injury by kickback

### 4.5.1 Chain brake

#### 4.5.1.1 Requirements

The chain-saw shall be fitted with a chain brake that can be activated manually by means of the front hand-guard. The chain brake release force shall be between 20 N and 60 N and the direction of movement shall be away from the operator.

The average stopping time shall not exceed 0,12 s and the maximum stopping time shall not exceed 0,15 s.

## 4.5.1.2 Verification

The chain brake release force and stopping time shall be verified in accordance with ISO 6535:2015.

## 4.5.2 Non-manual chain brake

### 4.5.2.1 Requirements

There shall also be a non-manual chain brake system that operates the chain brake when kickback occurs. This system shall meet the requirements for forest chain-saws given in ISO 13772:2018.

### 4.5.2.2 Verification

The non-manually activated chain brake system shall be verified by functional testing in accordance with ISO 13772:2018.

## 4.5.3 Kickback and chain stop angles

### 4.5.3.1 Requirements

The following requirement is only applicable for chain-saws with an engine displacement of less than 80 cm<sup>3</sup> and a guide bar length not exceeding 63 cm. At least one of the calculated kickback parameters ( $CKA_{wob}$  or  $CKA_{wb}$  or  $CKA_{cs}$ ) shall be less than 45°. This requirement shall be fulfilled for all guide bar and saw-chain combinations specified in the instructions. For definitions of the kickback parameters, see ISO 9518:2018.

NOTE Sufficient information to allow the setting of a limit is not available for chain-saws with an engine displacement of more than 80 cm<sup>3</sup>.

### 4.5.3.2 Verification

$CKA_{wob}$ ,  $CKA_{wb}$  and  $CKA_{cs}$  shall be verified by functional testing in accordance with ISO 9518:2018.

## 4.6 Chain catcher

### 4.6.1 Requirements

The chain-saw shall be fitted with a chain catcher located, and with dimensions and strength, in accordance with ISO 10726:2020. The chain catcher shall be replaceable.

### 4.6.2 Verification

Dimensions shall be verified by measurement. Strength requirements shall be verified by testing in accordance with ISO 10726:2020. Means for replacing the chain catcher shall be verified by inspection.

## 4.7 Spiked bumper

### 4.7.1 Requirements

The chain-saw shall be equipped with a spiked bumper (see [Figure 1](#)) or shall have provision for mounting one.

### 4.7.2 Verification

The presence of a spiked bumper or the provision for mounting one shall be verified by inspection.