



Designation: ~~D2911~~—~~10~~ **D2911 – 10**

Standard Specification for Dimensions and Tolerances for Plastic Bottles¹

This standard is issued under the fixed designation D2911; the number immediately following the designation indicates the year of original adoption or, in the case of revision, the year of last revision. A number in parentheses indicates the year of last reappraisal. A superscript epsilon (ϵ) indicates an editorial change since the last revision or reappraisal.

1. Scope

1.1 This specification covers the thread configuration and dimensions for finishes for plastic bottles with screw-type closures, having a maximum capacity of 18.9 L (5 gal) and a maximum bottle dimension of 305 mm (12 in.). Included are tolerances for bottle capacity and body dimensions.

1.2 The values stated in SI units are to be regarded as the standard.

1.3 The following precautionary caveat pertains only to the test methods portion, Section 8 of this specification. *This standard does not purport to address all of the safety concerns, if any, associated with its use. It is the responsibility of the user of this standard to establish appropriate safety and health practices and determine the applicability of regulatory limitations prior to use.*

NOTE 1—There is no known ISO equivalent to this standard.

2. Referenced Documents

2.1 *ASTM Standards*:²

[D618 Practice for Conditioning Plastics for Testing](#)

[D1898 Practice for Sampling of Plastics \(Withdrawn 1998\)](#)³

3. Terminology

3.1 *Definitions*:

3.1.1 *bottle finish*—the configuration of the neck or opening of the bottle which serves to engage specific parts of the closure in order to securely attach it to the bottle.

3.1.2 *bottle height*—the maximum dimension of a bottle in a plane perpendicular to the bottle base when the bottle is setting in its normal upright position.

3.1.3 *bottle thickness*—the smaller dimension in a plane parallel to the bottle base.

3.1.4 *bottle width*—the larger dimension in a plane parallel to the bottle base.

4. Dimensions and Recommended Variations

4.1 *Recommended Variations in Overflow Capacity*—In overflow capacity recommended variations of plastic bottles up to 18.9 L (5 gal) in size shall be in accordance with [Table 1](#).

4.2 *Recommended Variations in Body Dimensions*—The recommended variations in the body dimensions of plastic bottles covered by this specification shall be in accordance with [Table 2](#).

4.3 *Finish Dimensions and Design*—The bottle finish dimensions and design for the nine finishes covered by this specification shall be in accordance with [Figs. 1-8](#) and [Tables 3-10](#).

5. Sampling

5.1 A batch or lot shall be considered as a unit of manufacture.

¹ This specification is under the jurisdiction of ASTM Committee [D20](#) on Plastics and is the direct responsibility of Subcommittee [D20.19](#) on Film, Sheeting, and Molded Products.

Current edition approved July 1, 2010. Published September 2010. Originally approved in 1970. Last previous edition approved in 2005 as D2911 - 94 (2005). DOI: 10.1520/D2911-10.

² For referenced ASTM standards, visit the ASTM website, www.astm.org, or contact ASTM Customer Service at service@astm.org. For *Annual Book of ASTM Standards* volume information, refer to the standard's Document Summary page on the ASTM website.

³ The last approved version of this historical standard is referenced on www.astm.org.

TABLE 1 Bottle Overflow Capacity Tolerances for Plastic Bottles

Fluid Ounces				Millilitres			
Bottle Overflow Capacity		Tolerance (\pm)		Bottle Overflow Capacity		Tolerance (\pm)	
0.75	less than	0.75	0.05	22	less than	22	1.5
1.2	and less than	1.2	0.07	35	and less than	35	2.0
1.6	and less than	1.6	0.08	47	and less than	47	2.5
2.1	and less than	2.1	0.10	62	and less than	62	3.0
2.8	and less than	2.8	0.12	83	and less than	83	3.5
3.9	and less than	3.9	0.14	115	and less than	115	4
5.4	and less than	5.4	0.17	159	and less than	159	5
7.4	and less than	7.4	0.20	218	and less than	218	6
9.8	and less than	9.8	0.24	289	and less than	289	7
13	and less than	13	0.30	384	and less than	384	9
18	and less than	18	0.37	531	and less than	531	11
26	and less than	26	0.44	767	and less than	767	13
37	and less than	37	0.51	1092	and less than	1092	15
51	and less than	51	0.68	1505	and less than	1505	20
72	and less than	72	0.81	2125	and less than	2125	24
98	and less than	98	1.01	2892	and less than	2892	30
119	and less than	119	1.30	3512	and less than	3512	38
139	and less than	139	1.50	4103	and less than	4103	44
160	and less than	160	1.80	4723	and less than	4723	53
180	and less than	180	2.00	5313	and less than	5313	59
210	and less than	210	2.20	6199	and less than	6199	65
210	to 5 gallons		1 % of capacity	6199	to 18.89 litres		1 % of capacity

TABLE 2 Body Dimensional Tolerance

Range of Specific Dimensions		Height Dimensions		Width and Depth Dimensions	
in.	mm	in.	mm	in.	mm
0 up to but not including 1	0 to 25.40	0.030	0.76	0.030	0.76
1 up to but not including 2	25.40 to 50.80	0.030	0.76	0.050	1.27
2 up to but not including 4	50.80 to 101.60	0.050	1.27	0.060	1.52
4 up to but not including 6	101.60 to 152.40	0.050	1.27	0.080	2.03
6 up to but not including 8	152.40 to 203.20	0.060	1.52	0.090	2.29
8 up to but not including 10	203.20 to 254.00	0.060	1.52	0.110	2.79
10 up to but not including 12	254.00 to 304.80	0.080	2.03	0.120	3.05
12 up to but not including 15	304.80 to 381.00	0.090	2.29	0.150	3.81
15 up to but not including 18	381.00 to 457.20	0.110	2.79	0.150	3.81

ASTM D2911-10

5.2 Unless otherwise agreed upon between manufacturer and purchaser, the material shall be sampled in accordance with the procedure described in Section 9 of Practice **D1898**. Adequate statistical sampling prior to packaging shall be considered an acceptable alternative.

6. Conditioning

6.1 *Conditioning*—Condition the test specimens at $23 \pm 2^\circ\text{C}$ ($73.4 \pm 3.6^\circ\text{F}$) and $50 \pm 5\%$ relative humidity for not less than 40 h prior to test in accordance with Procedure A of Practice **D618** for those tests where conditioning is required. In cases of disagreement, the tolerances shall be $\pm 1^\circ\text{C}$ ($\pm 1.8^\circ\text{F}$) and $\pm 2\%$ relative humidity.

6.2 *Test Conditions*—Conduct tests in the standard laboratory atmosphere of $23 \pm 2^\circ\text{C}$ ($73.4 \pm 3.6^\circ\text{F}$) and $50 \pm 5\%$ relative humidity, unless otherwise specified in the test methods or in this specification. In cases of disagreement, the tolerances shall be $\pm 1^\circ\text{C}$ ($\pm 1.8^\circ\text{F}$) and $\pm 2\%$ relative humidity.

7. Apparatus

7.1 For Determining Bottle Capacity:

7.1.1 *Balance*, having an accuracy of $\pm 0.1\%$ or better at rated capacity (full scale).

7.1.2 *Pipet, Graduated Cylinder, and Beaker*, as required.

7.1.3 Conditioned water at $23 \pm 2.0^\circ\text{C}$ ($73.4 \pm 3.6^\circ\text{F}$) containing a wetting agent sufficient to flatten the meniscus and eliminate air bubbles.

NOTE 2—It is acceptable to use any liquid detergent as the wetting agent.

7.1.4 *Stop Watch*.

7.2 For Determining Finish and Body Dimensions:

7.2.1 *Micrometers, Vernier Height Gages, or Vernier Calipers* with an accuracy of $\pm 0.025\text{ mm}$ ($\pm 0.001\text{ in.}$).

7.2.2 *Internal Micrometers or Telescoping Gages* with an accuracy of $\pm 0.025\text{ mm}$ ($\pm 0.001\text{ in.}$).

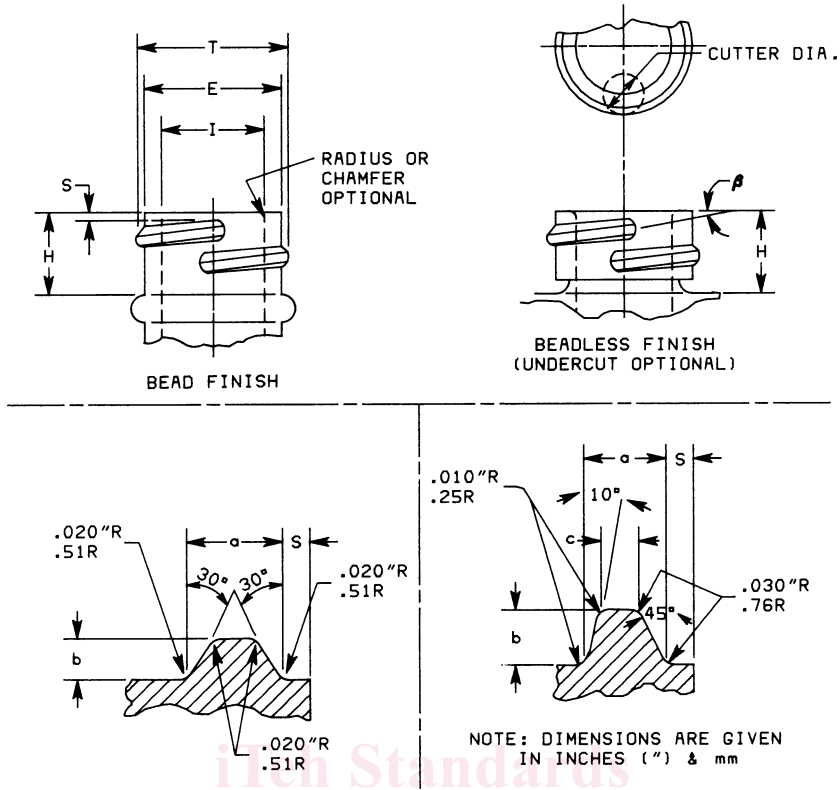

"L" Style All-Purpose Thread (Plastic or Metal Closures)					"M" Style Modified Buttress Thread (Plastic Closures)				
Threads/in.		a	b	c	Threads/in.	a	b	c	
5	in.	0.120	0.060	0.051	5	in.	0.120	0.060	0.049
	mm	3.05	1.52	1.30		mm	3.05	1.52	1.24
6	in.	0.094	0.047	0.040	6	in.	0.094	0.047	0.039
	mm	2.39	1.19	1.02		mm	2.39	1.19	0.99
8	in.	0.084	0.042	0.036	8	in.	0.084	0.042	0.035
	mm	2.13	1.07	0.91		mm	2.13	1.07	0.89

Example Thread Nomenclature
 "L" Style: L28SP400
 "M" Style: M28SP400

- NOTE 1—*T* and *E* dimensions are the average of two measurements across the major and minor axis. The limits of ovality will be determined by the container supplier and container customer, as necessary.
- NOTE 2—Dimension *H* is measured from the top of the finish to the point where diameter *T*, extended parallel to the centerline, intersects the bead or shoulder.
- NOTE 3—Contour of bead, undercut or shoulder is optional.
- NOTE 4—Unless otherwise specified, *I* min applies to the full length of the opening.
- NOTE 5—Concentricity of *I* min with respect to diameters *T* and *E* is not included. *I* min is specified for filler tube only.
- NOTE 6—A minimum of 1 full turn of thread shall be maintained.
- NOTE 7—Corresponding dimensions and finish details are shown in Table 3.
- NOTE 8—Consideration must be given to the sealing surface width for the sealing system being used.
- NOTE 9—Many child resistant closures, etc.

FIG. 1 SP 400 Finish Thread Cross Sections

NOTE: DIMENSIONS ARE GIVEN IN INCHES (") & mm

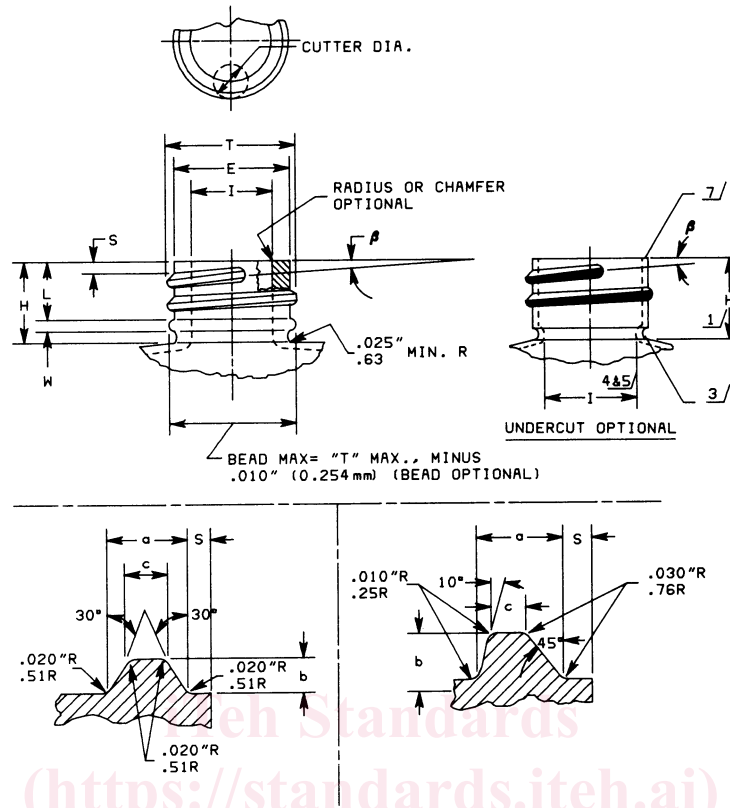

"L" Style All-Purpose Thread (Plastic or Metal Closures)					"M" Style Modified Buttress Thread (Plastic Closures)				
Threads/in.		a	b	c	Threads/in.	a	b	c	
6	in.	0.094	0.047	0.040	6	in.	0.094	0.047	0.039
	mm	2.39	1.19	1.02		mm	2.39	1.19	0.99
8	in.	0.084	0.042	0.036	8	in.	0.084	0.042	0.035
	mm	2.13	1.07	0.91		mm	2.13	1.07	0.89

Example Thread Nomenclature:

"L" Style: L22SP410

"M" Style: M22SP410

NOTE 1—Construction of neck from B to D must be held within the shaded area shown.

NOTE 2—A minimum of 1½ turns of thread shall be maintained.

NOTE 3—Unless otherwise specified, I min applies to the full length of the opening.

NOTE 4—Concentricity of I min with respect to diameters T and E is not included. I min is specified for filler tube only.

NOTE 5—T and E dimensions are the average of two measurements across the major and minor axis. The limits of ovality will be determined by the container supplier and container customer, as necessary.

NOTE 6—Consideration must be given to the sealing surface width for the sealing system being used.

NOTE 7—When valve style closures are used with this finish, special consideration must be given to a specific controlled inside diameter. In addition, it is acceptable to vary the dimensions indicated with asterisk (*) to ensure adequate material for finishing the inside diameter.

NOTE 8—Corresponding dimensions and details shown in Table 4.

FIG. 2 SP 410 Finish Thread Cross Sections

7.2.3 Commercial Scale, good quality calibrated in 1-mm or 1/32-in. increments.

8. Test Methods

8.1 Bottle Capacity:

8.1.1 Weigh the empty bottle and record the weight in grams.

8.1.2 Fill the bottle to overflow capacity with conditioned water containing the wetting agent, adjusting the meniscus by use of a pipet, if necessary, until the meniscus is tangent to the top of the finish surface. No more than 2 min shall be allowed for filling the bottle and no additional water shall be added after the bottle is filled to overflow and free of air bubbles.

NOTE: DIMENSIONS ARE GIVEN IN INCHES (") & mm

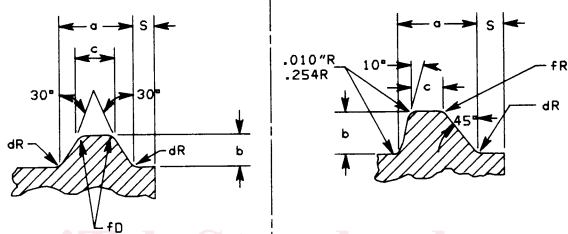
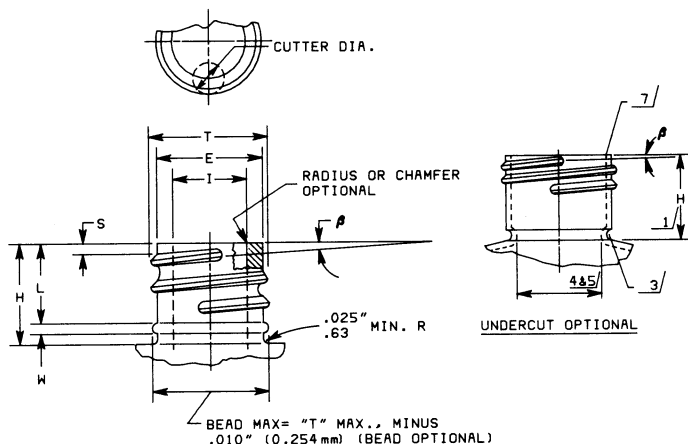

"L" Style All-Purpose Thread (Plastic or Metal Closures)						"M" Style Modified Buttress Thread (Plastic Closures)					
Threads/in.	a	b	c	d	f	Threads/in.	a	b	c	d	f
6	in. 0.094	0.047	0.040	0.020	0.020	6	in. 0.094	0.047	0.039	0.030	0.030
	mm 2.39	1.19	1.02	0.51	0.51		mm 2.39	1.19	0.99	0.76	0.76
8	in. 0.084	0.042	0.036	0.020	0.020	8	in. 0.084	0.042	0.035	0.030	0.030
	mm 2.13	1.07	0.91	0.51	0.51		mm 2.13	1.07	0.89	0.76	0.76
12	in. 0.045	0.030	0.011	0.015	0.005	12	in. 0.051	0.030	0.016	0.020	0.008
	mm 1.14	0.76	0.28	0.38	0.13		mm 1.29	0.76	0.41	0.51	0.22

Example Thread Nomenclature:

"L" Style: L22SP415

"M" Style: M22SP415

NOTE 1—Construction of neck from B to D must be held within the shaded area shown.

NOTE 2—A minimum of 2 turns of thread shall be maintained.

NOTE 3—Unless otherwise specified, I min applies to the full length of the opening.

NOTE 4—Concentricity of I min with respect to diameters T and E is not included. I min is specified for filler tube only.

NOTE 5—T and E dimensions are the average of two measurements across the major and minor axis. The limits of ovality will be determined by the container supplier and container customer, as necessary.

NOTE 6—Consideration must be given to the sealing surface width for the sealing system being used.

NOTE 7—When valve style closures are used with this finish, special consideration must be given to a specific controlled inside diameter. In addition, it is acceptable to vary the dimensions indicated with asterisk (*) to ensure adequate material for finishing the inside diameter.

NOTE 8—Corresponding dimensions and finish details are shown in Table 5.

FIG. 3 SP 415 Finish Thread Cross Sections

8.1.3 If the time exceeds 2 min, discard the sample and start over.

NOTE 3—The capacity of the container is somewhat time-dependent in that the force of the water in the container will cause the container sides to bulge with time and additional water will be needed to adjust to overflow capacity.

8.1.4 Weigh the filled bottle and record the weight in grams.

8.1.5 Calculate the bottle volume as follows:

$$B_v \text{ (mL)} = (B_f - B_o)/0.997$$

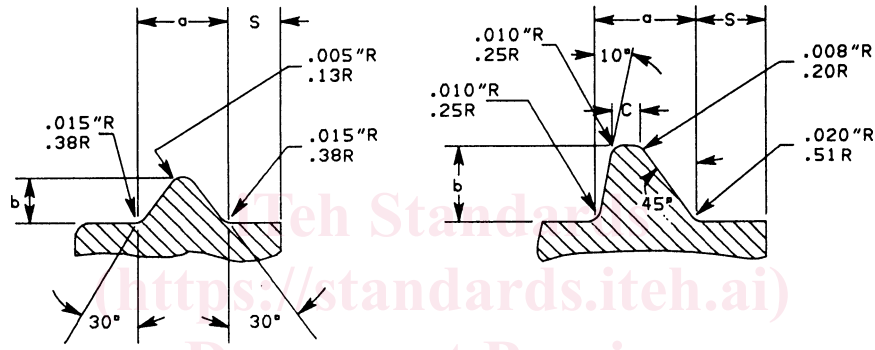
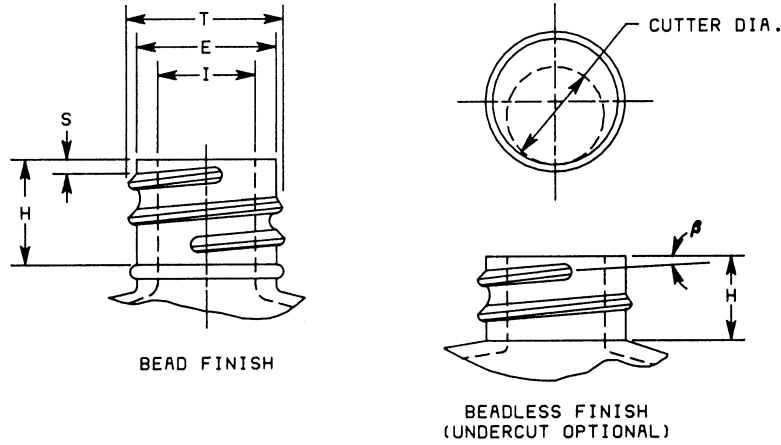

NOTE: DIMENSIONS ARE GIVEN IN INCHES (") & mm

NOTE 1—Contour of bead, undercut, or shoulder is optional.

"L" Style All-Purpose Thread (Plastic or Metal Closures)				"M" Style Modified Buttress Thread (Plastic Closures)				
Threads/in.		a	b	Threads/in.		a	b	c
12	in.	0.045	0.030	12	in.	0.051	0.030	0.016
	mm	1.14	0.76		mm	1.29	0.76	0.41
12	in.	0.045	0.030	12	in.	0.051	0.030	0.016
	mm	1.14	0.76		mm	1.29	0.76	0.41

NOTE 2—Example Thread Nomenclature
"L" Style: L15SP425 or "M" Style M15SP425

NOTE 3—Corresponding dimensions and finish details are shown in Table 6.

FIG. 4 SP 425 Finish Thread Cross Sections

where:

- B_v = volume of bottle, mL,
- B_f = weight of filled bottle, g,
- B_c = weight of empty bottle, g, and
- 0.997 = weight of water (g/mL) at $23 \pm 2.0^\circ\text{C}$ ($73.4 \pm 3.6^\circ\text{F}$).

$$B_v \text{ (fluid oz)} = (B_f - B_c) / 29.50$$

where: 29.50 = weight of water (g/fluid oz) at $23 \pm 2.0^\circ\text{C}$ ($73.4 \pm 3.6^\circ\text{F}$).

8.1.6 Determine the volume in millilitres (fluid ounces) for each test specimen.

8.1.7 Report the arithmetic average volume of the specimens tested as the bottle capacity of the batch or lot from which the samples were chosen.

8.2 Body Dimensions:

8.2.1 Using a suitable micrometer, a vernier height gauge, or a scale, measure the height of the bottle.