



Designation: ~~D6493-05~~ Designation: D6493 – 05 (Reapproved 2010)

## Standard Test Methods for Softening Point of Hydrocarbon Resins by Automated Ring-and-Ball Apparatus<sup>1</sup>

This standard is issued under the fixed designation D6493; the number immediately following the designation indicates the year of original adoption or, in the case of revision, the year of last revision. A number in parentheses indicates the year of last reapproval. A superscript epsilon ( $\epsilon$ ) indicates an editorial change since the last revision or reapproval.

### 1. Scope\*

1.1 These test methods are intended for determining the softening point of hydrocarbon resins and similar materials by means of an automated ring-and-ball apparatus. Portions are similar in technical content to the automated-apparatus versions of Test Methods D36, E28, and ISO 4625.

1.1.1 The ring-and-ball softening point of a hydrocarbon resin may also be determined with lower precision using the manual ring-and-ball softening point procedure in Test Methods E28.

1.2 The values stated in SI units are to be regarded as the standard. The values given in parentheses are for information only.

1.3 *This standard method does not purport to address all of the safety concerns, if any, associated with its use. It is the responsibility of the user of this standard to establish appropriate safety and health practices and determine the applicability of regulatory limitations prior to use.*

### 2. Referenced Documents

#### 2.1 ASTM Standards:<sup>2</sup>

D36 Test Method for Softening Point of Bitumen (Ring-and-Ball Apparatus)

E1 Specification for ASTM Liquid-in-Glass Thermometers

E28 Test Methods for Softening Point of Resins Derived from Naval Stores by Ring-and-Ball Apparatus

E177 Practice for Use of the Terms Precision and Bias in ASTM Test Methods

E691 Practice for Conducting an Interlaboratory Study to Determine the Precision of a Test Method

#### 2.2 ISO Standard:

ISO 4625 Binders for paints and varnishes—Determination of softening point—Ring-and-ball method<sup>3</sup>

### 3. Summary of Test Method

3.1 These test methods are for the determination of a hydrocarbon resin's softening point—the temperature at which a disk of the resin held within a horizontal ring is forced downward a distance of 25.4 mm (1.00 in.) under the weight of a standard steel ball, as the specimen is heated at 5°C/min. in a specified liquid bath.

### 4. Significance and Use

4.1 For hydrocarbon resins, softening does not take place at a definite temperature. As the temperature rises, these materials gradually change from brittle solids or very viscous liquids to less viscous liquids. For this reason, determination of the softening point must be made by a fixed, arbitrary, and closely defined method if the results obtained are to be comparable.

### 5. Sample Preparation

5.1 *Preparation of Sample by the Pour Method:* This procedure is suitable for resins that can be heated and poured without adverse effect on the softening point.

5.1.1 Select a sample representative of the material to be tested. The sample should consist of flakes, pastilles, or broken lumps. Avoid inclusion of finely divided material or dust.

5.1.2 Select a quantity of resin having a volume at least twice that necessary to fill the desired number of rings, and melt it in a clean container, using an oven, hot plate, sand bath or oil bath to prevent local overheating. If necessary, stir slowly, taking care

<sup>1</sup> These test methods are under the jurisdiction of ASTM Committee D01 on Paint and Related Coatings, Materials, and Applications and are the direct responsibility of Subcommittee D01.34 on Pine Chemicals and Hydrocarbon Resins.

Current edition approved July 1, 2005-15, 2010. Published August 2005-September 2010. Originally approved in 1999. Last previous edition approved in 1999-2005 as ~~D6493-99~~-D6493 – 05. DOI: 10.1520/D6493-05R10.

<sup>2</sup> For referenced ASTM standards, visit the ASTM website, www.astm.org, or contact ASTM Customer Service at service@astm.org. For *Annual Book of ASTM Standards* volume information, refer to the standard's Document Summary page on the ASTM website.

<sup>3</sup> Available from American National Standards Institute (ANSI), 25 W. 43rd St., 4th Floor, New York, NY 10036, <http://www.ansi.org>.

\*A Summary of Changes section appears at the end of this standard.

to avoid incorporating air bubbles in the sample. Melt the sample completely, but do not heat it above a temperature necessary to pour the material readily. The time from the beginning of heating to pouring should not exceed 15 min.

5.1.3 For materials that tend to crack or shrink in the ring on cooling, immediately before filling the ring, preheat the ring to approximately the temperature at which the material is to be poured. The ring, while being filled, should rest **bottom down** (see Fig. 1(a)) on a suitable metal surface. Pour the sample into the ring so as to leave an excess on cooling. After cooling a minimum of 30 min., trim off the excess resin from the top and outside of the ring. To remove excess resin from the top, cut the excess off cleanly with a heated knife or spatula, or grasp the ring in a pair of tongs and draw the top surface quickly and firmly over the surface of a heated plate.

NOTE 1—If the determination is repeated, use a clean container and a fresh sample.

5.2 *Preparation of Sample by the Powder Method:* This procedure is suitable for high softening-point materials that cannot be heated and poured without adverse effects on the softening point. See Appendix X1.1, Alternate Sample Preparation Procedures.

5.3 *Preparation of Samples Having a Low Softening Point (up to 35°C (95°F)):*

5.3.1 Place a ring on a piece of aluminum foil. Pour the material to be tested into the ring, then place the foil and the filled ring on dry ice or in a freezer to cool. The material in the ring must be free of bubbles.

5.3.2 After cooling, cut and scrape off any excess material using a slightly heated spatula, then slide the ring gently from the foil. Place the ring in the supporting apparatus, and perform the softening point determination in accordance with Section 12.

## 6. Apparatus

6.1 *Automated Ring-and-Ball Softening Point Instrument,* having a test assembly consisting of: a ring holder, a metal plate, and a cover mounted on two support rods (see Fig. 1(b) and (d)), a temperature-measuring device (in accordance with Specification E1), a heating unit, a heating-rate controller, and a digital temperature display.

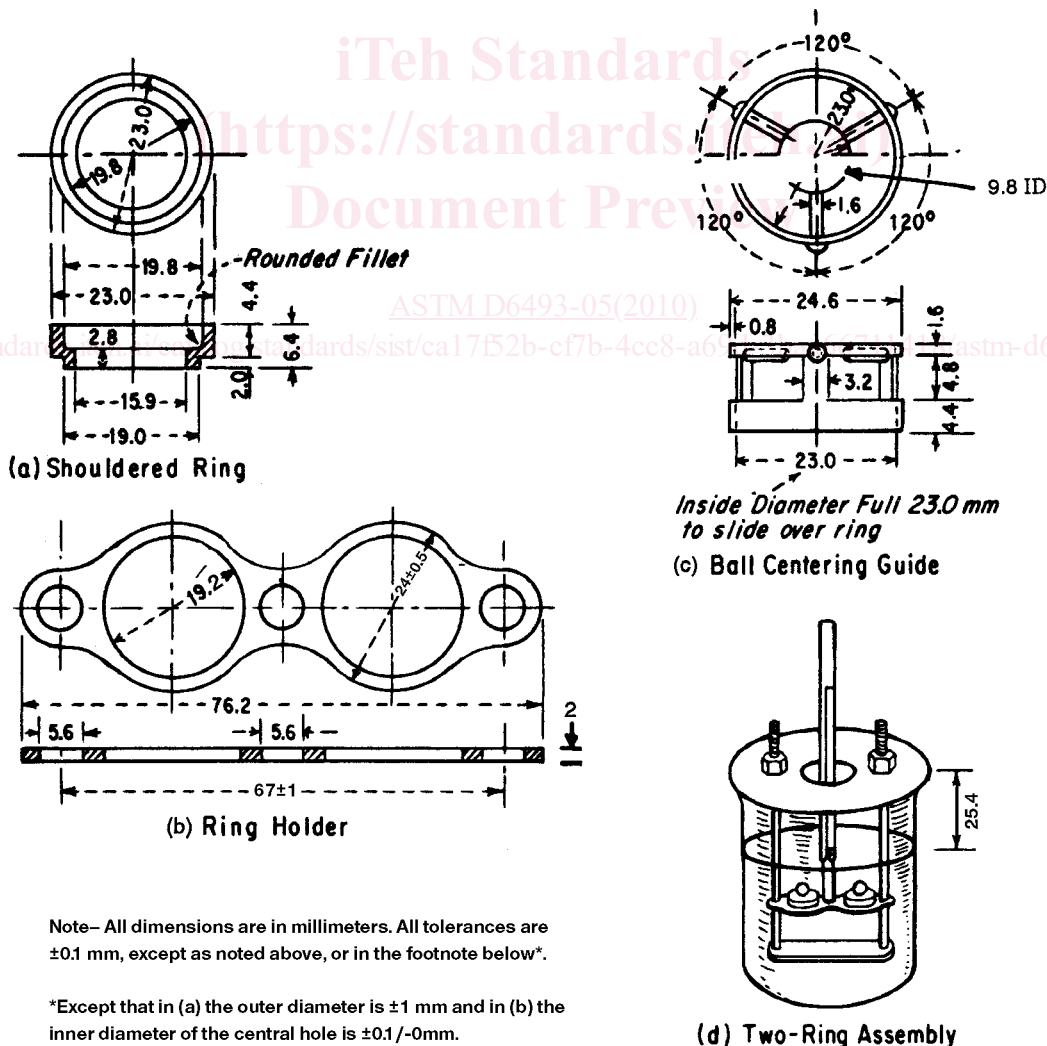

Note— All dimensions are in millimeters. All tolerances are  $\pm 0.1$  mm, except as noted above, or in the footnote below\*.

\*Except that in (a) the outer diameter is  $\pm 1$  mm and in (b) the inner diameter of the central hole is  $\pm 0.1/-0$  mm.

FIG. 1 Shouldered Ring, Ring Holder, Ball-Centering Guide, and Assembly of Apparatus

6.2 *Ring*—A brass, shouldered ring conforming to the dimensions shown in Fig. 1(a).

6.3 *Ball*—A steel ball,  $9.53 \pm 0.1$  mm ( $\frac{3}{8}$  in.) in diameter, weighing between 3.45 and 3.55 g.

6.4 *Ball-Centering Guide (optional)*, having the dimensions given in Fig. 1(c).

6.5 *Beaker*, 600 mL, borosilicate glass, to hold the bath liquid. ensure that the dimensions will properly fit the heating unit.

6.6 *Stirrer*—Either a magnetic stirring motor and a magnetic stir bar, or a direct-driven agitator with a stirring motor. The dimensions of a stir bar must be such that the bar spins freely under the test assembly. The bath must be stirred at a speed sufficient to ensure uniform temperature distribution without causing significant sideways displacement of the resin as it sags below the ring.

## 7. Reagents and Materials

### 7.1 Bath Liquids:

7.1.1 *Distilled or Deionized Water, Freshly Boiled*—For softening points between 35°C (95°F) and 80°C (176°F).

7.1.1.1 Use distilled or deionized water that has been cooled to at least 27°C (81°F) below the anticipated softening point, but in no case lower than 5°C (41°F).

7.1.2 *USP Glycerin*—For softening points between 80°C (176°F) and 150°C (302°F). Repeated use of glycerin (over about four heating cycles) may affect results. Open storage of glycerin can increase the moisture content, which may affect results. Replace with fresh glycerin if any change in appearance or viscosity is noted. Use fresh glycerin for referee work. **Warning**—Glycerin must not be used for softening points greater than 150°C (302°F) due to the 160°C (320°F) flash point of glycerin.

7.1.3 *Silicone Oil (Polydimethylsiloxane)*—For softening points above 80°C (176°F). The oil must have a temperature range of 60 to 200°C+ (140 to 392°F+), remain clear throughout the temperature range, have no apparent effect or reactivity with the test specimen, remain free of moisture, and maintain a relatively uniform viscosity and stirring rate within the temperature range.<sup>4</sup>

NOTE 2—Replace with fresh silicone oil if any change in appearance is noted. Do not use silicone oil that contains any gels; gels are an indicator that degradation has occurred.

7.1.4 *Ethylene Glycol*—For softening points up to 35°C (95°F).

7.1.4.1 Prepare a fresh 50/50 (volume/volume) mixture of distilled water and ethylene glycol prior to softening point determination. Alternatively, for softening points between 0°C and 35°C, a 50/50 (v/v) mixture of glycerin and water may be used.

## 8. Calibration

8.1 The calibration of any automated ring and ball softening point apparatus must be performed on a regular basis, since accurate temperature control is required. Follow the manufacturer's instructions for calibration of the instrument.

## 9. Procedure for Materials Having a Softening Point Between 35°C (95°F) and <80°C (176°F)

9.1 Add a stir bar or stirrer to the 600-mL beaker. Add approximately 500 mL of water, conforming to the requirements in 7.1.1. Ensure that the beaker is properly positioned on the heater in the test unit. Place the prepared sample rings in the test assembly. Place a ball-centering guide and ball on top of each sample ring. Place the test assembly in the beaker. Place the temperature-measuring device in the opening in the cover of the test assembly. Verify that the control unit is set for the correct bath liquid.

9.2 Heat the bath so that the temperature of the water is raised uniformly at a rate of 5°C (10°F)/min. Protect the bath from drafts, using shields if necessary. Reject any test in which the rate of temperature rise does not fall within these limits. The test is complete when the light beam has been interrupted by the falling ball and material.

NOTE 3—Rigid adherence to the prescribed rate of heating is absolutely essential for reproducibility of results.

9.3 Record as the softening point the temperature displayed on the unit after the light beam has been interrupted by the falling ball and material.

9.4 Start the cooling process in the instrument. **Remove** the temperature measuring device from the test insert, then remove the test insert from the beakers. Thoroughly clean the test insert, ball, and ring in a suitable solvent.

## 10. Procedure for Materials Having Softening Points Between 80°C (176°F) and 150°C (302°F)

10.1 Use the same procedure as described in Section 9, except fill the bath with glycerin or silicone oil.

NOTE 4—For materials softening around 80°C (176°F) report the bath liquid used, since a glycerin or silicone oil bath will yield a slightly higher result than a water bath.

## 11. Procedure for Materials Having Softening Points Above 150°C (302°F)

11.1 Use the same procedure as described in Section 9, except fill the bath with silicone oil (see Note 2).

## 12. Procedure for Materials Having Softening Points Below 35°C (95°F)

12.1 *Additional Apparatus:*

<sup>4</sup> Supporting data have been filed at ASTM International Headquarters and may be obtained by requesting Research Report RR:D01-1113.