



Designation: D1974/D1974M – 10

# Standard Practice for Methods of Closing, Sealing, and Reinforcing Fiberboard Boxes<sup>1</sup>

This standard is issued under the fixed designation D1974/D1974M; the number immediately following the designation indicates the year of original adoption or, in the case of revision, the year of last revision. A number in parentheses indicates the year of last reapproval. A superscript epsilon ( $\epsilon$ ) indicates an editorial change since the last revision or reapproval.

*This standard has been approved for use by agencies of the U.S. Department of Defense.*

## 1. Scope

1.1 This practice describes several methods for closing, sealing, and reinforcing fiberboard (solid and corrugated, excluding triple wall) shipping boxes used for shipment. One or several methods listed in this practice may be referenced in regulations, specifications, or contracts. (See Appendix for cross reference).

1.2 The values stated in either SI units or inch-pound units are to be regarded separately as standard. The values stated in each system may not be exact equivalents; therefore, each system shall be used independently of the other. Combining values from the two systems may result in non-conformance with the standard.

NOTE 1—This practice is intended to be workable in both inch-pound units and SI units. Unit conversions are intended to be functional but are not necessarily exact; this should not significantly affect the performance of the closing, sealing, or reinforcing methods. Descriptions in inch-pound and SI units are considered interchangeable in this practice.

NOTE 2—All references to this standard should be made by closure number.

1.3 *This standard does not purport to address all of the safety concerns, if any, associated with its use. It is the responsibility of the user of this standard to establish appropriate safety and health practices and determine the applicability of regulatory limitations prior to use.*

## 2. Referenced Documents

### 2.1 ASTM Standards:<sup>2</sup>

D644 Test Method for Moisture Content of Paper and Paperboard by Oven Drying (Withdrawn 2010)<sup>3</sup>

<sup>1</sup> This practice is under the jurisdiction of ASTM Committee D10 on Packaging and is the direct responsibility of Subcommittee D10.27 on Paper and Paperboard Products.

Current edition approved Aug. 1, 2010. Published September 2010. Originally approved in 1991. Last previous edition approved in 2003 as D1974 – 98(2003). DOI: 10.1520/D1974\_D1974M-10.

<sup>2</sup> For referenced ASTM standards, visit the ASTM website, www.astm.org, or contact ASTM Customer Service at service@astm.org. For *Annual Book of ASTM Standards* volume information, refer to the standard's Document Summary page on the ASTM website.

<sup>3</sup> The last approved version of this historical standard is referenced on www.astm.org.

D951 Test Method for Water Resistance of Shipping Containers by Spray Method

D996 Terminology of Packaging and Distribution Environments

D3654/D3654M Test Methods for Shear Adhesion of Pressure-Sensitive Tapes

D3759/D3759M Test Method for Breaking Strength and Elongation of Pressure-Sensitive Tape

D3950 Specification for Strapping, Nonmetallic (and Joining Methods)

D3953 Specification for Strapping, Flat Steel and Seals

D4169 Practice for Performance Testing of Shipping Containers and Systems

D4675 Guide for Selection and Use of Flat Strapping Materials<sup>1</sup>

D4727/D4727M Specification for Corrugated and Solid Fiberboard Sheet Stock (Container Grade) and Cut Shapes

D5118/D5118M Practice for Fabrication of Fiberboard Shipping Boxes

D5330/D5330M Specification for Pressure-Sensitive Tape for Packaging, Filament-Reinforced

D5486/D5486M Specification for Pressure-Sensitive Tape for Packaging, Box Closure, and Sealing

D5570 Test Method for Water Resistance of Tape and Adhesives Used as Box Closure

D5749 Specification for Reinforced and Plain Gummed Tape for Sealing and Securing

F592 Terminology of Collated and Cohered Fasteners and Their Application Tools

### 2.2 U.S. Government Documents:<sup>4</sup>

MMM-A-250 Adhesive, Water Resistant (For Closure of Fiberboard Boxes)

### 2.3 Other Standards:

International Fiberboard Case Code<sup>5</sup>

<sup>4</sup> Available from Standardization Documents Order Desk, DODSSP, Bldg. 4, Section D, 700 Robbins Ave., Philadelphia, PA 19111-5098, http://dodssp.daps.dla.mil.

<sup>5</sup> International Fiberboard Case Code, European Federation of Manufacturers of Corrugated Board (FEFCO), 37 rue d'Amsterdam, 75008, Paris, France, 874-63-76.



NOTE 3—FEFCO<sup>5</sup> established a code of box styles to facilitate international trade. The box codes consist of four-digit numbers; for example, a regular slotted container was assigned the code 0201.

### 3. Terminology

3.1 General definitions for packaging and distribution environments are found in Terminology **D996**.

#### 3.2 Definitions:

3.2.1 *crown*—staple end opposite staple point, connecting both staple legs and providing bearing area (**F592**).

3.2.2 *leg*—staple part connecting staple crown with staple point, driven through and into or through materials being fastened (**F592**).

3.2.3 *stitch*—staple cut and formed from wire immediately prior to driving by same machine (**F592**).

#### 3.3 Definitions of Terms Specific to This Standard:

3.3.1 *closure*—the means of securing the flaps or covers of a box so that the box will not accidentally open during normal shipment, handling, and storage.

3.3.2 *leg thickness*—dimension of staple-leg cross section measured parallel to staple-crown axis (**F592**).

3.3.3 *leg width*—dimension of staple-leg cross section measured perpendicular to staple-crown axis (**F592**).

3.3.4 *reinforcing*—the means (when required) of improving the stability and integrity of a fiberboard box or closure so as to increase the performance level of the box during normal handling, shipping, or storage.

3.3.5 *sealing*—the means (when required) of making a box reasonably impervious to the entrance of extraneous material (such as dust) or to prevent the leakage of the box contents during distribution.

3.3.6 *setup*—the forming of a knocked-down box (or box section) into a box (section) ready for filling, including the end, cover, and section closures made before the box is filled.

3.3.7 *staple*—preformed U-shaped wire fastener usually with two same-size pointed or pointless legs connected by crown located opposite staple-point ends; designed to be driven by strike, pneumatic, electric, manual, or spring tools through or through and into layers of penetrable material and to hold two or more pieces together.

3.3.8 *wide crown staple*—a staple whose nominal width is 1¼ in. [approximately 32 mm] or greater.

3.3.9 *wide crown stitch*—a stitch whose nominal width is 1¼ in. [approximately 32 mm] or greater.

### 4. Significance and Use

4.1 The means of closing the flaps of corrugated shipping containers is one of the important decisions for a shipper. It may affect the overall material cost, the labor costs, the packaging equipment costs, and the performance of the box during distribution.

4.2 This practice provides a list of many available procedures for closing, sealing, and reinforcing boxes. Most of these describe a particular packaging material and a particular use of it on a box. Some methods involve package performance

testing; any closure or reinforcement which passes prescribed tests (usually on the proposed box and contents) is considered to comply with that section of this practice. Performance-based methods are encouraged because they allow for considerable flexibility in the choice of packaging materials and methods yet provide assurance of a given level of performance.

4.3 A diverse range of methods are described in this practice but relative performance levels are not given. Laboratory package testing such as Practice **D4169** and field experience are recommended to rate alternative methods on performance for the intended use.

4.4 The descriptions of materials and methods in this practice provide direction for the procurement of materials and for their common uses on boxes. These descriptions may be sufficient for some specification purposes, but others will require more thorough material and application requirements than those given here.

4.5 The list of methods in this practice is not exhaustive; deviation or variation from the listed methods is possible with the approval of the appropriate parties referencing this practice. Depending on the characteristics of the contents, the specific shipping container, the acceptable package costs, the distribution hazards, and the desired degree of assurance of successful shipment, more stringent methods than those listed may be needed or less stringent methods than those listed may be adequate. The methods described are typical uses of the closure, reinforcing, or sealing materials; many of these materials can be used for other box styles or other methods on boxes but all of these are not included in this practice. Materials for box closure, reinforcement, or sealing are commercially available which have higher or lower performance characteristics than those listed in this practice; these may often be used in a lesser or greater quantity than the described applications of the listed materials.

4.6 This practice assumes the following:

4.6.1 The shipping container and inner packing are properly designed for the contents and the distribution hazards (see Practices **D4169** and **D5118/D5118M**),

4.6.2 Normal, reasonable care is taken in shipment, including storage, handling, loading, and bracing, and

4.6.3 Normal, reasonable care is taken in the application of the closure, reinforcing, or sealing materials to the shipping container.

### 5. Materials and Equipment

#### 5.1 Adhesives:

5.1.1 *Hot Melt Adhesives*—Hot melt adhesives are solid at room temperature, liquified by heat, applied molten, and solid upon cooling to bond two surfaces. They are based on thermoplastic polymers modified with resins or waxes, or both, and are usually applied in the range of approximately 300 to 400°F [approximately 150 to 200°C]. The adhesive should maintain its functionality in environmental conditions expected in distribution and storage.

5.1.2 *Water-Borne Adhesives*—Several types of adhesives are available in which water is the vehicle or solvent. These are typically applied at room temperature and the surfaces are

compressed together until the adhesive develops sufficient strength to maintain substrate contact. The adhesive should maintain its functionality in environmental conditions expected in distribution and storage. The federal specification applicable to adhesives is MMM-A-250.

5.1.3 Semi-automatic and fully automatic box closure equipment is available for the application of adhesives. Hot melt adhesives are also applied by hand held “guns.” Adhesives work best on clean, dry surfaces. It is important to have the box flaps held in place until the hot melt adhesive solidifies or the water borne adhesive develops sufficient bond.

## 5.2 Pressure-Sensitive Tape:

5.2.1 *Pressure-Sensitive, Film-Backed Tape*—This tape consists of a film backing, usually a biaxially oriented polypropylene or polyester (some polyvinyl chloride films are also used), with a high tack pressure-sensitive adhesive. No solvents, heat, or moistening are needed. The tape should maintain its functionality in the environmental conditions expected in distribution and storage. The applicable reference is Specification **D5486/D5486M**.

5.2.2 *Pressure-Sensitive Filament Tape*—This type of tape typically consists of fiberglass filaments embedded in a pressure-sensitive adhesive with a protective film backing. Several grades of tape are available. The tape should maintain its functionality in environmental conditions expected in distribution and storage. The applicable reference is Specification **D5530**.

5.2.3 *Pressure-Sensitive Paper Tape*—This type of tape has a backing of kraft paper and a pressure-sensitive adhesive. The tape should maintain its functionality in environmental conditions expected in distribution and storage. The applicable reference is Specification **D5486/D5486M**.

5.2.4 A wide variety of tape dispensing and applying equipment is available. Hand-held dispensers are common. Pressure-sensitive tapes also capable of being applied by equipment at high speeds. Tapes work best on clean, dry surfaces. It is important to give an adequate rubdown to pressure-sensitive tapes to develop sufficient bond to hold the flaps closed.

5.2.5 Uses of pressure-sensitive tape in the closure, sealing, and reinforcing methods call for their commonly available commercial widths. The widths common in the U.S. Customary system are not identical to the available metric replacement widths. The most frequent width conversions are as follows:

U.S. Customary	Metric
in.	mm
0.5	12
0.75	18
1	24
2	48
3	72

NOTE 4—The effect of this width difference on package performance is not considered significant.<sup>6</sup>

## 5.3 Gummed (Remoistenable) Tape:

5.3.1 *Reinforced Gummed Tapes*—This type of tape has a water activated adhesive and contains glass reinforcing fibers embedded between two sheets of paper, using nonasphaltic binders. Many constructions are available. The tape should maintain its functionality in environmental conditions expected in distribution and storage. The applicable reference is Specification **D5749**.

5.3.2 *Gummed Paper Tape*—This type of tape has a backing of kraft paper and a water activated adhesive. The tape should maintain its functionality in environmental conditions expected in distribution and storage. The applicable reference is Specification **D5749**.

5.3.3 A wide variety of tape dispensing and applying equipment is available. Table top dispensers are common. Gummed tapes are capable of being applied by equipment at high speeds. Tapes work best on clean, dry surfaces. It is important to hold water activated tapes in place until they develop sufficient bond to hold the flaps closed.

## 5.4 Staples and Stitches:

### 5.4.1 Staples:

5.4.1.1 Staples shall be of good commercial quality steel and have a minimum tensile strength of 80 000 psi [550 mPa]. They shall have a rust-resistant coating of copper, zinc, or other material. Staples and stitches listed in the closure methods of this practice shall meet or exceed the following minimums:

Crown Width	Leg Width	Leg Thickness
0.50 in. [12.5 mm]	0.100 in. [2.5 mm]	0.017 in. [0.43 mm]
1.25 in. [32 mm]	0.072 in. [1.9 mm]	0.033 in. [0.84 mm]

5.4.1.2 Staples are collated and cohered into strips or rolls. The strips are designed for loading into straight magazines. The roll, also called a coil, allows the loading of a large number of staples into a tool.

5.4.1.3 Staples are driven by staplers. Two types of staplers are in common use.

(a) One type of stapler uses moving anvils to clinch the staple legs around the fiberboard. These tools drive the staple legs through the flaps, simultaneously inserting anvils through the flap surface to meet and clinch the staple legs so they grab the inner flaps and secure them to the outer flaps. The anvils then retract from the flaps.

(b) The other type of stapler uses a stationary anvil to clinch the staple legs. The anvil may be supported by a pedestal or by an arm attached to the stapler.

(c) Each type of stapler is available as a manual device and as a powered device. The manually operated staplers are usually portable although some are mounted on frames and activated by a foot pedal. The latter are commonly called “bottomers” used to close the bottom flaps of a box before filling. The powered tools may be electric or pneumatic. Staples may be driven by portable staplers or by stationary heads mounted in semi- or fully-automatic equipment for moderate production requirements.

### 5.4.2 Stitches:

5.4.2.1 Stitches shall be of good commercial quality steel. Common nominal crown widths are 0.50 in. [12.5 mm] and 1.25 in. [32 mm]. Nominal leg width is 0.100 in. [2.5 mm]. Nominal leg thicknesses are 0.014 in. [0.36 mm] and 0.017 in. [0.43 mm]. The minimum tensile strength is 100 000 psi [690

<sup>6</sup> Supporting data have been filed at ASTM International Headquarters and may be obtained by requesting Research Report RR:D10-1004. Contact ASTM Customer Service at service@astm.org.



mPa] for wire of thickness (0.014 in. [0.36 mm]. The minimum tensile strength is 80 000 psi [550 mPa] for wire of thickness 0.017 in. [0.43 mm]. They shall have a rust resistant coating of copper, zinc, or other material.

5.4.2.2 Stitches are driven by electric or pneumatic stitchers. These tools cut a section of wire from a spool of wire, form a stitch (with crown and legs) and drive the legs through the box flaps. The legs are clinched on a clinch block, thereby securing the inner and outer flaps. Stitchers are stationary machines.

5.5 *Strapping*—See Guide **D4675** for a discussion of strapings and their application equipment.

#### 5.6 *Environmental Considerations:*

5.6.1 *General*—Although the environmental impact of a package is a component of the package design and evaluation process, the integrity of the product should not be compromised. Product damage or disposal resulting from package failure, or both, may well cause greater environmental impact than the package. Product containment, protection, and preservation, along with consumer safety, remain the primary functions of the package.

5.6.2 *Toxic Content*—The use of potentially toxic materials in packaging components is a concern for their presence in emissions when packaging is incinerated, or in leachate when packaging is landfilled. Materials used for the closure, sealing, or reinforcement of boxes shall not have any lead, cadmium, mercury, or hexavalent chromium which has been intentionally introduced as a component during manufacturing or distribution as opposed to the incidental presence of any of these elements. Box closure, sealing, and reinforcing materials presented in this standard typically meet this requirement.

5.6.3 *Solid Waste*—Considerations of packaging solid waste involve the total mass and volume of all package components. The closure, sealing, and reinforcing components are usually less than 1 % of this total. While these materials are still part of solid waste considerations, emphasis should be on the total.

5.6.3.1 *Source Reduction*—Reductions in closure, sealing, and reinforcing materials should be consistent with performance and material requirements specified in contracts and regulations and with good engineering practice.

5.6.3.2 *Reuse*—Closure, sealing, and reinforcing materials which allow the reuse of fiberboard boxes are encouraged.

5.6.3.3 *Recycling*—Efforts should be focused on maximizing the reuse and fiber recovery of fiberboard boxes. One consideration in the choice of a closure, sealing, or reinforcing material should be compatibility with the recycling of old fiberboard containers. Materials should be chosen which can be removed from a box prior to recycling, removed from the pulper (vessel for dispersing old fiberboard into pulp slurry), or otherwise removed in the recycling process. The materials should then be suitable for appropriate recycling, incineration, or landfill in accordance with applicable regulations. If the materials are not removable in the recycling process, they should not cause significant reductions in the properties of the recycled paper or paperboard.

5.7 *Water Resistance*—When a box becomes wet, the performance of the box and its closure are reduced. It is desirable

to have box-closure methods which retain an ability to keep the box closed when wet. Sealing or reinforcing methods sometimes are useful to improve performance of wet boxes and closures. Water resistance is sometimes a regulatory or contractual requirement.

5.7.1 Where boxes are closed by gluing or taping, an adhesive is considered water resistant if, when set, cannot be dissolved by water after at least 24 h immersion. The water resistance of tape and adhesives shall be measured by Test Method **D5570**.

5.7.2 The water resistance of methods of closing, sealing, and reinforcing boxes can be evaluated on packages. Box Closure Methods 1D and 1E provide some measurement of water resistance. From a practical standpoint, successful completion of the following performance tests provides a demonstration of water resistance. Subject three samples of box, contents, and box closure to the rain cycle of Test Method **D951** at medium intensity (2 in./h or 50 mm/h) for 6 h. The boxes shall immediately be subjected to the drop tests of Practice **D4169**, Element A at Assurance Level II with the final (sixth) drop conducted from twice the specified drop height onto a side of the box. The sample packages shall then be able to be picked up and moved without the flaps opening.

## 6. Methods of Box Closure

6.1 *Performance-Based Closures* (for all box styles)—When a Method 1 box closure is referenced, any reasonable means of closing the box is allowed which is able to successfully complete the prescribed performance test on the proposed package with contents. Care must be taken with the choice of acceptance criteria for a closure. Often the criterion is that after the tests, the box remain closed in a condition suited for normal sale or use; some limited box or closure damage may be acceptable.

6.1.1 *Closure Method 1A*—The closure must be able to complete the test sequence of Practice **D4169**, Distribution Cycle 3 or 4, Assurance Level 1.

6.1.2 *Closure Method 1B*—The closure must be able to complete the test sequence of Practice **D4169**, Distribution Cycle 3 or 4, Assurance Level II.

6.1.3 *Closure Method 1C*—The closure must be able to complete the test sequence of Practice **D4169**, Distribution Cycle 3 or 4, Assurance Level III.

6.1.4 *Box Closure 1D*—The closure must be able to complete the test sequence of Practice **D4169**, Distribution Cycle 18, Assurance Level I.

6.1.5 *Box Closure 1E*—The closure must be able to complete the test sequence of Practice **D4169**, Distribution Cycle 18, Assurance Level II.

6.1.6 *Box Closure 1F*—The closure must be able to complete the test sequence of Practice **D4169**, Distribution Cycle 18, Assurance Level III.

6.2 *Closure Methods for Regular Slotted Containers, Box Code 0201, Center Special Slotted Container, 0204, and similar box styles.*

NOTE 5—See 2.3 (and Note 2) for information in box codes.

6.2.1 *Adhesive Closures of RSC's and Similar Boxes:*

6.2.1.1 *Closure Method 2A1*—The box shall be closed with a hot-melt adhesive in strips a minimum of 1 in. [25 mm] long and ¼ in. [6 mm] wide after compression. There shall be a minimum of four strips, two on each side of the center line; the separation between strips shall be a maximum of 2 in. [50 mm] with the innermost strips being ½ in. [13 mm] from each side of the center line.

6.2.1.2 *Closure Method 2A2*—The box shall be closed with a hot-melt adhesive which will maintain bond at temperatures for a range from – 20°F [–29°C] to 165°F [74°C]. Adhesive shall be applied in at least eight full-length strips on each inner flap, each strip having a minimum full width of 3/16 in. [5 mm] after compression. Strips shall not be more than 1½ in. [38 mm] apart with one strip not more than ½ in. [13 mm] from each side of the center seam. See Fig. 1.

6.2.1.3 *Closure Method 2A3*—The box shall be closed with a waterborne adhesive by securely bonding at least 50 % of the contact area of the flaps. The bonded areas shall extend to within ½ in. [13 mm] of the center seam. See Fig. 2.

6.2.1.4 *Closure Method 2A4*—The box shall be closed with the application of adhesive conforming with MMM-A-250 by securely bonding at least 75 % of the contact area of the flaps. The adhesive shall be applied within ¼ in. [6 mm] of the edges and scorelines of the inner flaps.

6.2.1.5 *Closure Method 2A5*—The box shall be closed with a hot melt or a waterborne adhesive securely bonding at least 25 % of the contact area of the flaps. The bonded areas shall extend to within ½ in. [13 mm] of the center seam.

6.2.2 *Pressure-Sensitive Tape Closure of RSC's and Similar Boxes:*

6.2.2.1 *Closure Method 2B1*—The box shall be closed with 2 in. [48 mm] wide pressure-sensitive film backed tape applied over the center seams of the box, continuing at least 2 in. [50 mm] onto the box ends. The tape shall have a nominal 2 mil [0.05 mm] biaxially oriented polypropylene backing and conform with Specification D5486/D5486M, Type III. See Fig. 3.

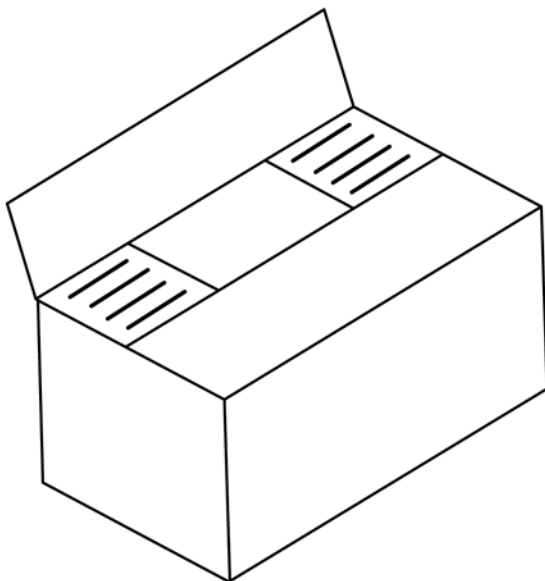

FIG. 1 Example of Closure Method 2A2

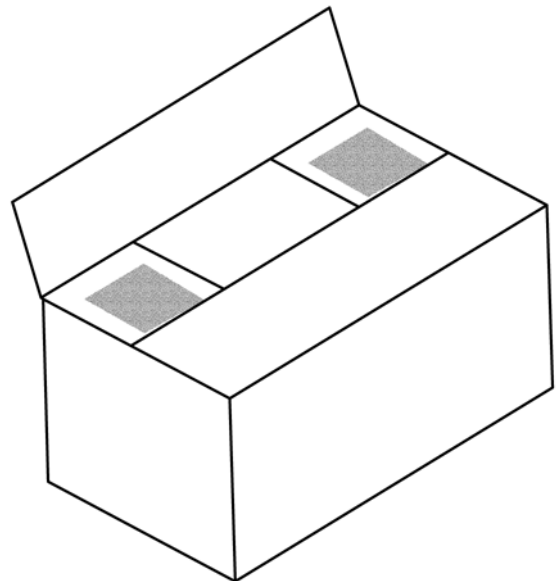

FIG. 2 Example of Closure Methods 2A3 and 2C5

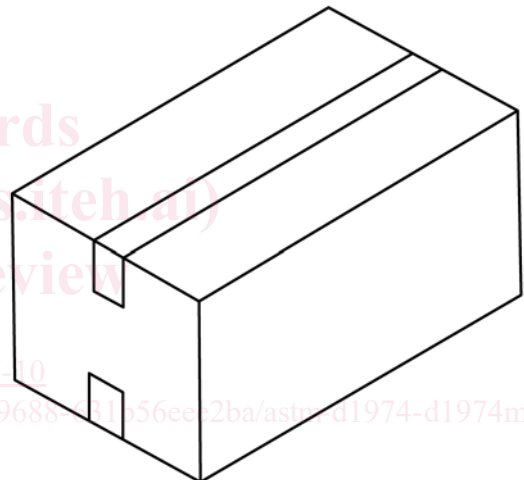

FIG. 3 Example of Closure Methods 2B1, 2B2, 2B3, 2B4, 2B5, 2B6, 2C1, 2C2, 2C3, and 2C4

6.2.2.2 *Closure Method 2B2*—The box shall be closed with 2 in. [48 mm] wide pressure-sensitive film backed tape applied over the center seams of the box, continuing at least 2 in. [50 mm] onto the box ends. The tape shall have a nominal 1.4 mil [0.035-mm] biaxially oriented polypropylene backing with a nominal tape thickness of 2.2 mils [0.06 mm]. The adhesive shall have a holding power to fiberboard, Test Method D3654/D3654M, Procedure A, of at least 2000 min. See Fig. 3.

6.2.2.3 *Closure Method 2B3*—The box shall be closed with 2 in. [48 mm] wide pressure-sensitive film backed tape applied over the center seams of the box, continuing at least 2 in. [50 mm] onto the box ends. The colored tape shall conform with Specification D5486/D5486M Type II, Class 1 or 2. See Fig. 3.

6.2.2.4 *Closure Method 2B6*—The box shall be closed with 2 in. [48 mm] wide paper tape applied over the center seams of the box, continuing at least 2 in. [50 mm] onto the box ends. The tape shall comply with Specification D5486/D5486M, Type V. See Fig. 3.

6.2.2.5 *Closure Method 2B7*—The box shall be closed with 2 in. [48 mm] wide paper tape applied over the center seams of the box, continuing at least 2 in. [50 mm] onto the box ends. Four additional strips of tape shall be centered over the seam formed by the edges of the outer flaps and the end panels; the tape shall extend within  $\frac{3}{4}$  in. [19 mm] of the box corners. The tape shall conform with Specification **D5486/D5486M**, Type V. See **Fig. 4**.

6.2.3 *Gummed Tape Closure of RSC's and Similar Boxes (Including One Panel Folder, international box codes 0401, 403, 415, and 416—see also Practice D5118/D5118M)*:

6.2.3.1 *Closure Method 2C1*—The box shall be closed with 3 in. [75 mm] wide reinforced gummed tape applied over the center seams of the box, continuing at least  $2\frac{1}{2}$  in. [65 mm] onto the box ends. The tape shall have glass reinforcements in both the machine and cross machine direction (or at angles to provide some cross direction strength). See **Fig. 3**.

6.2.3.2 *Closure Method 2C2*—The box shall be closed with 3 in. [75 mm] wide reinforced gummed tape applied over the center seams of the box, continuing at least  $2\frac{1}{2}$  in. [65 mm] onto the box ends. The tape shall comply with Specification **D5749**, Type 1. See **Fig. 3**.

6.2.3.3 *Closure Method 2C3*—The box shall be closed with 3 in. [75 mm] wide reinforced gummed tape applied over the center seams of the box, continuing at least  $2\frac{1}{2}$  in. [65 mm] onto the box ends. The tape shall comply with Specification **D5749**, Type II, Grade B. See **Fig. 3**.

6.2.3.4 *Closure Method 2C4*—The box shall be closed with 2 in. [48 mm] wide paper tape applied over the center seams of the box, continuing at least 2 in. [50 mm] onto the box ends. The tape shall comply with Specification **D5749**, Type II, Grade B. See **Fig. 3**.

6.2.3.5 *Closure Method 2C5*—The box shall be closed with 2 in. [48 mm] wide paper tape applied over the center seams of the box, continuing at least 2 in. [50 mm] onto the box ends. Four additional strips of tape shall be centered over the seam formed by the edges of the outer flaps and the end panels; the tape shall extend within  $\frac{3}{4}$  in. [19 mm] of the box corners. The tape shall comply with Specification **D5749**, Type II, Grade B. See **Fig. 4**.

6.2.3.6 *Closure Method 2C6*—The box shall be closed with 2 in. [50 mm] tape applied over all open seams of the box. Tape on the vertical seams will cover the entire length of each seam and conclude at least 2 in. [50 mm] around the bottom edge of the box end. The tape on the center seam will conclude at least 2 in. [50 mm] over the center seam onto the end of the box. The tape shall comply with Specification **D5749**, Type II, Grade B. See **Fig. 5**.

6.2.4 *Staple and Stitch Closure and Setup of RSC's and Similar Boxes—General*—Staples are used both for box setup and final closure. Stitcher operation requires that the stitcher's head and clinch block be on opposite sides of the flaps being joined. Hence, stitches are used only for the setup where access of the clinching block is not restricted. The following methods apply to the use of staples for both setup and final closure and for box setup with stitches.

6.2.4.1 *Closure Method 2D1*—The box shall be closed with  $\frac{1}{2}$ -in. crown staples or stitches applied to each side of the center seam in an area where outer flaps overlay inner flaps; fasteners should not be more than  $2\frac{1}{2}$  in. [65 mm] apart. See **Fig. 6**. See **Table 1** for quantities required for various box widths.

6.2.4.2 *Closure Method 2D2*—The box shall be closed with  $\frac{1}{2}$ -in. crown staples or stitches applied to each side of the center seam in the area where outer flaps overlay inner flaps and to the sides of the outside flaps; fasteners shall not be more than  $2\frac{1}{2}$  in. [65 mm] apart. See **Fig. 7**. See **Table 1** for quantities required for various widths.

6.2.4.3 *Closure Method 2D3*—The box shall be closed with  $\frac{1}{2}$ -in. crown staples or stitches distributed uniformly over the areas where outer flaps overlay inner flaps. **Table 1** presents the number of staples/stitches for each end for stated box widths. See **Fig. 8**.

6.2.4.4 *Closure Method 2D4*—The box shall be closed with wide crown staples or stitches applied across the center seam not more than 5 in. [125 mm] apart in the area where outer flaps overlay inner flaps. See **Fig. 9**. See **Table 2** for quantities required for various box widths.

6.2.4.5 *Closure Method 2D5*—The box shall be closed with wide crown staples or stitches applied across the center seam in the area where the outer flaps overlay inner flaps and to the

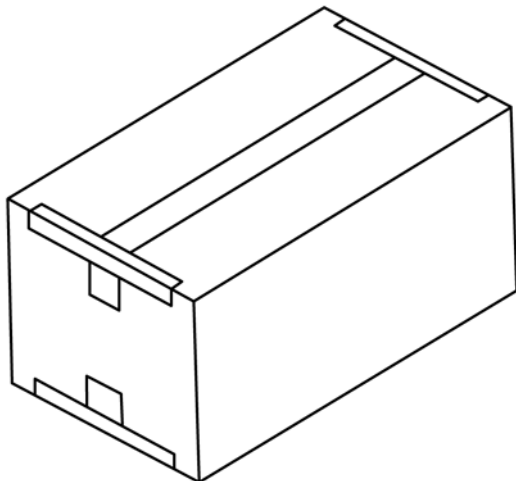

**FIG. 4** Example of Closure Method 2B7

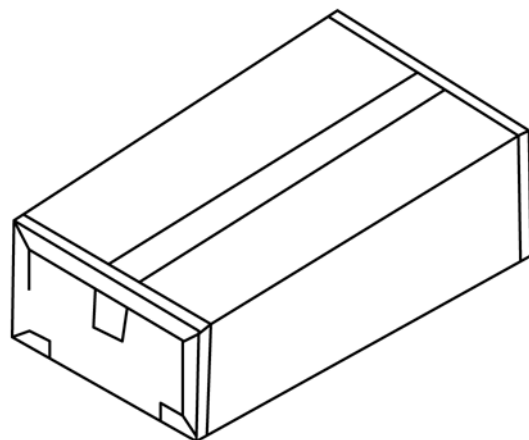

**FIG. 5** Example of Sealing Method 2C