

ISO/TC 178

Secretariat: AFNOR

Voting begins on:
2020-10-13

Voting terminates on:
2020-12-08

Electrical requirements for lifts, escalators and moving walks —

Part 2: Electromagnetic compatibility with regard to immunity

*Exigences électriques pour ascenseurs, escaliers mécaniques et
trottoirs roulants —*

*Partie 2: Compatibilité électromagnétique en ce qui concerne
l'immunité*

RECIPIENTS OF THIS DRAFT ARE INVITED TO SUBMIT, WITH THEIR COMMENTS, NOTIFICATION OF ANY RELEVANT PATENT RIGHTS OF WHICH THEY ARE AWARE AND TO PROVIDE SUPPORTING DOCUMENTATION.

IN ADDITION TO THEIR EVALUATION AS BEING ACCEPTABLE FOR INDUSTRIAL, TECHNOLOGICAL, COMMERCIAL AND USER PURPOSES, DRAFT INTERNATIONAL STANDARDS MAY ON OCCASION HAVE TO BE CONSIDERED IN THE LIGHT OF THEIR POTENTIAL TO BECOME STANDARDS TO WHICH REFERENCE MAY BE MADE IN NATIONAL REGULATIONS.



Reference number
ISO/FDIS 8102-2:2020(E)

iTeh STANDARD PREVIEW
(standards.iteh.ai)
Full standard:
<https://standards.iteh.ai/catalog/standards/sist/883ebfc9-8c78-4f78-b470-1074d14e6acc/iso-fdis-8102-2>



COPYRIGHT PROTECTED DOCUMENT

© ISO 2020

All rights reserved. Unless otherwise specified, or required in the context of its implementation, no part of this publication may be reproduced or utilized otherwise in any form or by any means, electronic or mechanical, including photocopying, or posting on the internet or an intranet, without prior written permission. Permission can be requested from either ISO at the address below or ISO's member body in the country of the requester.

ISO copyright office
CP 401 • Ch. de Blandonnet 8
CH-1214 Vernier, Geneva
Phone: +41 22 749 01 11
Email: copyright@iso.org
Website: www.iso.org

Published in Switzerland

Contents

	Page
Foreword.....	iv
Introduction.....	v
1 Scope.....	1
2 Normative references.....	1
3 Terms and definitions.....	2
4 Test procedure.....	5
5 Applicability of tests.....	6
6 Evaluation of tests results.....	6
6.1 General.....	6
6.2 Performance criteria.....	7
6.3 Enclosure ports of safety circuits.....	7
7 Information for use.....	7
Bibliography.....	16

iTeh STANDARD PREVIEW
(standards.iteh.ai)

Full standard:
<https://standards.iteh.ai/catalog/standards/sist/883ebfc9-8c78-4f78-b470-1074d14e6acc/iso-fdis-8102-2>

Foreword

ISO (the International Organization for Standardization) is a worldwide federation of national standards bodies (ISO member bodies). The work of preparing International Standards is normally carried out through ISO technical committees. Each member body interested in a subject for which a technical committee has been established has the right to be represented on that committee. International organizations, governmental and non-governmental, in liaison with ISO, also take part in the work. ISO collaborates closely with the International Electrotechnical Commission (IEC) on all matters of electrotechnical standardization.

The procedures used to develop this document and those intended for its further maintenance are described in the ISO/IEC Directives, Part 1. In particular, the different approval criteria needed for the different types of ISO documents should be noted. This document was drafted in accordance with the editorial rules of the ISO/IEC Directives, Part 2 (see www.iso.org/directives).

Attention is drawn to the possibility that some of the elements of this document may be the subject of patent rights. ISO shall not be held responsible for identifying any or all such patent rights. Details of any patent rights identified during the development of the document will be in the Introduction and/or on the ISO list of patent declarations received (see www.iso.org/patents).

Any trade name used in this document is information given for the convenience of users and does not constitute an endorsement.

For an explanation of the voluntary nature of standards, the meaning of ISO specific terms and expressions related to conformity assessment, as well as information about ISO's adherence to the World Trade Organization (WTO) principles in the Technical Barriers to Trade (TBT), see www.iso.org/iso/foreword.html.

This document was prepared by Technical Committee ISO/TC 178, *Lifts, escalators and moving walks*.

This document cancels and replaces ISO 22200:2009.

Any feedback or questions on this document should be directed to the user's national standards body. A complete listing of these bodies can be found at www.iso.org/members.html.

Introduction

This document is a type-C standard as stated in ISO 12100.

This document is of relevance, in particular, for the following stakeholder groups representing the market players with regard to machinery safety:

- machine manufacturers (small, medium and large enterprises);
- health and safety bodies (regulators, accident prevention organisations, market surveillance etc.)

Others can be affected by the level of machinery safety achieved with the means of the document by the above-mentioned stakeholder groups:

- machine users/employers (small, medium and large enterprises);
- machine users/employees (e.g. trade unions, organizations for people with special needs);
- service providers, e. g. for maintenance (small, medium and large enterprises);
- consumers (in case of machinery intended for use by consumers).

The above-mentioned stakeholder groups have been given the possibility to participate at the drafting process of this document.

The machinery concerned and the extent to which hazards, hazardous situations or hazardous events are covered are indicated in the Scope of this document.

When requirements of this type-C standard are different from those which are stated in type-A or type-B standards, the requirements of this type-C standard take precedence over the requirements of the other standards for machines that have been designed and built according to the requirements of this type-C standard.

This document is based on European Standard EN 12016:2013.

The requirements of this document have been specified so as to ensure a level of electromagnetic immunity which will allow minimal disturbance to the product family.

Two levels of immunity are given which have been selected such that the immunity levels for safety circuit apparatus are higher than the immunity levels for general function apparatus. The higher levels cover the possibility for example of disturbances emanating from hand-held transmitters in close proximity to safety circuit apparatus.

However, neither level covers cases where an extremely low probability of occurrence exists.

Test levels and immunity performance criteria are defined for:

- apparatus which are safety components or are used in conjunction with safety components, (safety circuits);
- apparatus used in general function circuits.

The immunity levels given are on the basis that equipment of the product family range is installed both indoor and outdoor in all types of building and, generally, is connected to a low voltage system.

Due to the size of an installed lift, it becomes impracticable to test the total assembly either in a test laboratory or in situ where the uncontrolled environment can also influence the test procedures and results. This applies also to measurements within the car. Similar considerations regarding dimensions apply equally to the testing of escalators and moving walks.

The following explains the rationale to the revisions of this document.

- New performance criterion C has been specified for voltage dip and voltage interruption.

ISO/FDIS 8102-2:2020(E)

- Because of extension of operating frequencies in the digital mobile telephone services and wireless communication systems, new requirements have been added on radio frequency electromagnetic field to cover up to 2 655 MHz.
- For the evaluation of test results regarding the radio equipment as defined by national regulations used in apparatus/assembly of apparatus, the exclusion band defined by the standards applies for that specific radio equipment.
- In addition, the uncontrolled operation of radio transmitter used in combined apparatus/assembly of apparatus is not allowed.

The related EMC product family standard for emission is ISO 8102-1.

iTeh STANDARD PREVIEW
(standards.iteh.ai)
Full standard:
<https://standards.iteh.ai/catalog/standards/sist/883ebfc9-8c78-4f78-b470-1074d14e6acc/iso-fdis-8102-2>

Electrical requirements for lifts, escalators and moving walks —

Part 2: Electromagnetic compatibility with regard to immunity

1 Scope

This document specifies the immunity performance criteria and test levels for apparatus used in lifts, escalators and moving walks which are intended to be permanently installed in buildings including the basic safety requirements in regard to their electromagnetic environment. These levels represent essential EMC requirements.

This document refers to EM conditions as existing in residential, office and industrial buildings.

This document addresses commonly known EMC related hazards and hazardous situations relevant to lifts, escalators and moving walks when they are used as intended and under the conditions foreseen by the lift installer or escalator and/or moving walk manufacturer.

It is assumed that no ports connected to safety circuit only are rated at currents greater than 100 amps.

It is assumed that mobile telephones and radio transmitters used at frequencies and power of that stated in [Table 1](#) are not placed within 200 mm distance from safety circuit(s).

However:

- performance criteria and test levels for apparatus/assembly of apparatus used in general function circuits do not cover situations with an extremely low probability of occurrence;
- this document does not apply to other apparatus already proven to be in conformity to the EMC national regulation, and not related to the safety of the lift, escalator or moving walk, such as lighting apparatus, communication apparatus, etc.

This document does not apply to electromagnetic environments such as:

- radio transmitter stations;
- railways and metros;
- heavy industrial plant;
- electricity power stations;

which need additional investigations.

This document is not applicable to apparatus which were manufactured before the date of its publication.

2 Normative references

The following documents are referred to in the text in such a way that some or all of their content constitutes requirements of this document. For dated references, only the edition cited applies. For undated references, the latest edition of the referenced document (including any amendments) applies.

IEC 60050-161:1990+A1:2017, *International Electrotechnical Vocabulary — Chapter 161: Electromagnetic compatibility*

IEC 61000-4-2:2008, *Electromagnetic Compatibility (EMC) — Part 4-2: Testing and measurement techniques; Electrostatic discharge immunity test*

IEC 61000-4-3:2006+A1:2007, *Electromagnetic compatibility (EMC) — Part 4-3: Testing and measurement techniques; Radiated, radio-frequency, electromagnetic field immunity test 2)*

IEC 61000-4-4:2012, *Electromagnetic compatibility (EMC) — Part 4-4: Testing and measurement techniques — Electrical fast transient/burst immunity test*

IEC 61000-4-5:2014+A1:2017, *Electromagnetic compatibility (EMC) — Part 4-5: Testing and measurement techniques — Surge immunity test*

IEC 61000-4-6:2013, *Electromagnetic Compatibility (EMC) — Part 4-6: Testing and measurement techniques — Immunity to conducted disturbances, induced by radio-frequency fields*

IEC 61000-4-11:2004+A1:2017, *Electromagnetic Compatibility (EMC) — Part 4-11: Testing and measurement techniques — Voltage dips, short interruptions and voltage variations immunity tests*

IEC 61000-6-1:2005, *Electromagnetic compatibility — Part 6-1: Generic standards — Immunity for residential, commercial and light-industrial environments*

IEC 61000-6-2:2005, *Electromagnetic Compatibility (EMC) — Part 6-2: Generic standards — Immunity for industrial environments*

CISPR 32:2015, *modified, Information technology equipment - Radio disturbance characteristics - Limits and methods of measurement*

CISPR 24:2010+A1:2015, *Information technology equipment - Immunity characteristics - Limits and methods of measurement*

3 Terms and definitions

For the purpose of this document, the terms and definitions given in IEC 61000-6-1:2005, IEC 61000-6-2:2005 and the following apply.

ISO and IEC maintain terminological databases for use in standardization at the following addresses:

- ISO Online browsing platform: available at <https://www.iso.org/obp>
- IEC Electropedia: available at <http://www.electropedia.org/>

3.1 assembly of apparatus

arrangement of interconnected apparatus, which can be tested together

Note 1 to entry: See [Figure 1](#) and [Figure 2](#) as examples.

3.2 apparatus

assembly of components with an intrinsic function as defined by its manufacturer

Note 1 to entry: See [Figure 1](#) and [Figure 2](#) as examples.

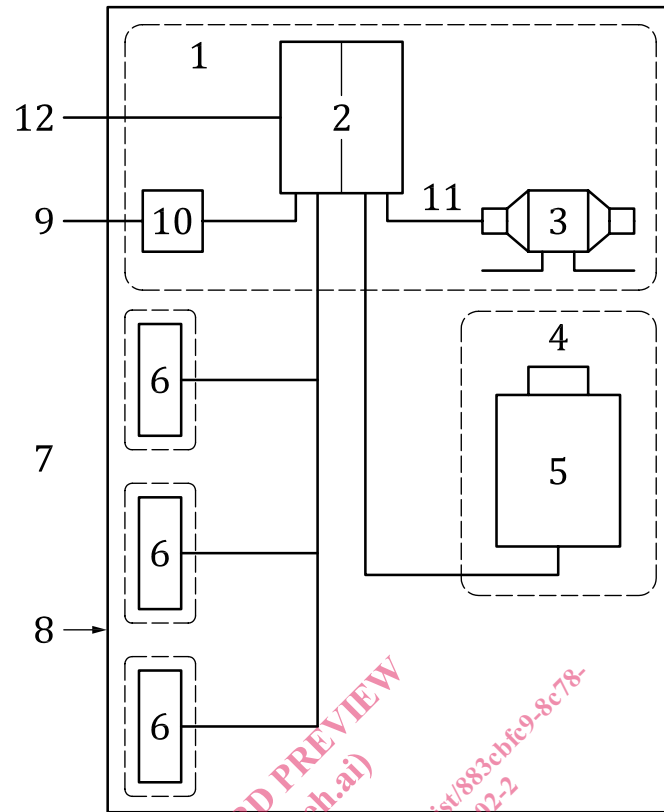

Key



assembly of apparatus

- | | | | |
|---|--|----|---|
| 1 | machinery space | 7 | landings |
| 2 | main control / control cabinet | 8 | system boundary |
| 3 | machine | 9 | AC – and/or DC power ports |
| 4 | door control | 10 | main switch |
| 5 | lift car | 11 | output power port |
| 6 | apparatus installed at the landing (e.g. push buttons, indicators) | 12 | ports for monitoring and remote alarm systems |

Figure 1 — EMC example (immunity) for lift systems

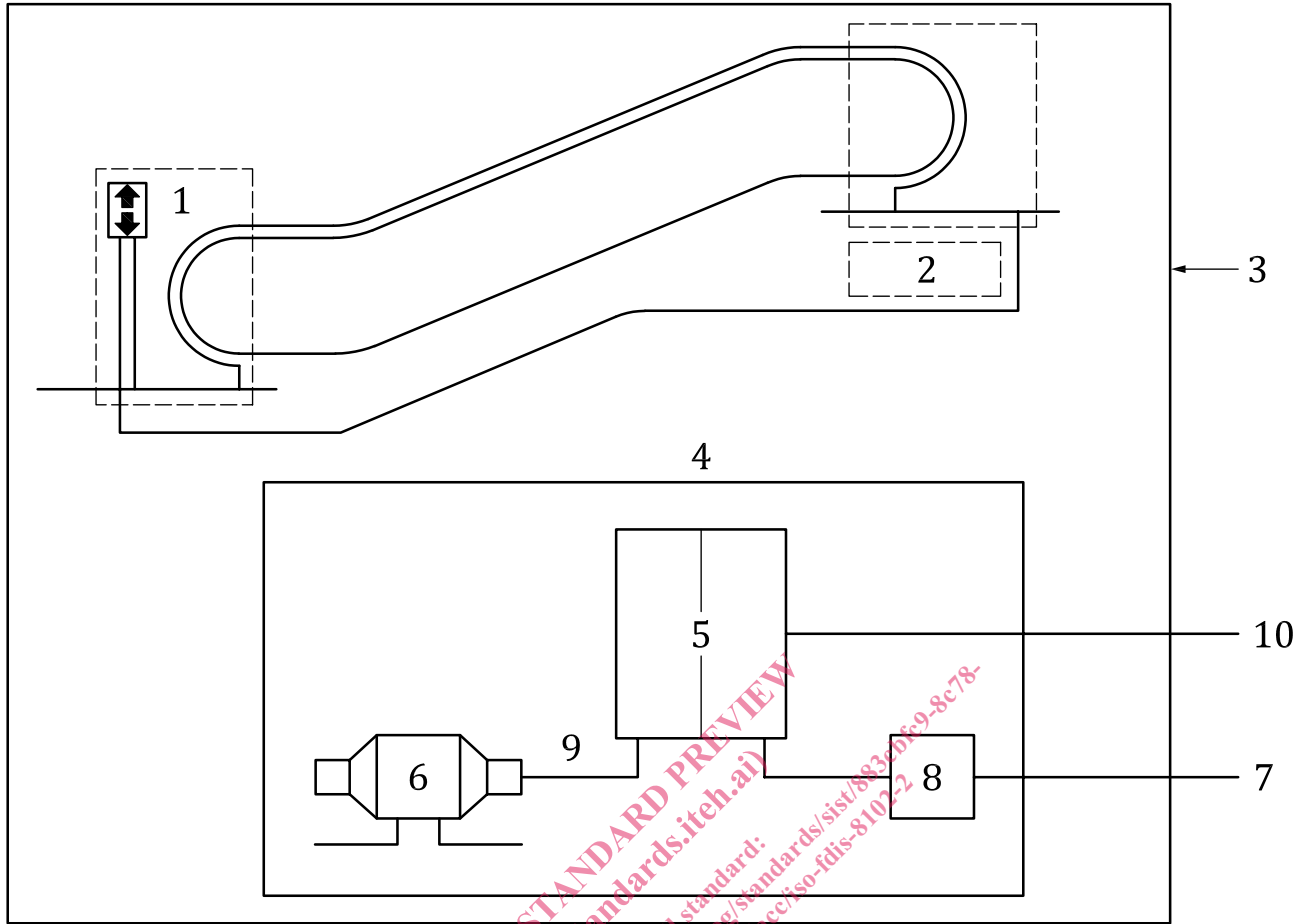

Key

assembly of apparatus

- | | | | |
|---|-------------------------------|----|----------------------------|
| 1 | control panels | 6 | machine |
| 2 | machinery space (see 4 to 10) | 7 | AC – and/or DC power ports |
| 3 | system boundary | 8 | main switch |
| 4 | machinery space | 9 | output power port |
| 5 | main control/control cabinet | 10 | ports for monitoring |

NOTE the machinery space can also be an external room.

Figure 2 — EMC example (immunity) for escalator and moving walk systems

3.3 enclosure port

physical boundary of apparatus/assembly of apparatus through which electromagnetic fields can radiate or impinge

Note 1 to entry: See [Figure 3](#) as example.

3.4 general function circuit

circuitry used in apparatus which does not incorporate safety circuits

Note 1 to entry: See [Figure 1](#) to [Figure 3](#).