

---

---

**Paints and varnishes — On-site test  
methods on quality assessment for  
interior wall coatings**

iTeh Standards  
(<https://standards.itih.ai>)  
Document Preview

[ISO 23169:2020](https://standards.itih.ai/catalog/standards/iso/b9251fe3-527a-4a4b-8322-d8de2d947029/iso-23169-2020)

<https://standards.itih.ai/catalog/standards/iso/b9251fe3-527a-4a4b-8322-d8de2d947029/iso-23169-2020>



iTeh Standards  
(<https://standards.iteh.ai>)  
Document Preview

[ISO 23169:2020](https://standards.iteh.ai/catalog/standards/iso/b9251fe3-527a-4a4b-8322-d8de2d947029/iso-23169-2020)

<https://standards.iteh.ai/catalog/standards/iso/b9251fe3-527a-4a4b-8322-d8de2d947029/iso-23169-2020>



**COPYRIGHT PROTECTED DOCUMENT**

© ISO 2020

All rights reserved. Unless otherwise specified, or required in the context of its implementation, no part of this publication may be reproduced or utilized otherwise in any form or by any means, electronic or mechanical, including photocopying, or posting on the internet or an intranet, without prior written permission. Permission can be requested from either ISO at the address below or ISO's member body in the country of the requester.

ISO copyright office  
CP 401 • Ch. de Blandonnet 8  
CH-1214 Vernier, Geneva  
Phone: +41 22 749 01 11  
Fax: +41 22 749 09 47  
Email: [copyright@iso.org](mailto:copyright@iso.org)  
Website: [www.iso.org](http://www.iso.org)

Published in Switzerland

# Contents

	Page
<b>Foreword</b> .....	<b>iv</b>
<b>Introduction</b> .....	<b>v</b>
<b>1 Scope</b> .....	<b>1</b>
<b>2 Normative references</b> .....	<b>1</b>
<b>3 Terms and definitions</b> .....	<b>1</b>
<b>4 Symbols</b> .....	<b>2</b>
<b>5 On-site cleanability (stain removal) test</b> .....	<b>3</b>
5.1 Principle.....	3
5.2 Apparatus.....	3
5.3 Reagents.....	4
5.4 Procedure.....	5
5.4.1 Division of test area.....	5
5.4.2 Determination of the initial tristimulus value of the untreated coating.....	6
5.4.3 Application of soiling agent.....	7
5.4.4 Cleaning of soilings.....	8
5.4.5 Determination of the tristimulus value after soil removal.....	8
5.4.6 Calculation of the cleanability.....	9
5.4.7 Evaluation with different soiling agents.....	9
5.4.8 Comprehensive evaluation of stain removal of wall coating films.....	10
<b>6 On-site wet-scrub resistance test</b> .....	<b>10</b>
6.1 Principle.....	10
6.2 Apparatus.....	10
6.3 Procedure.....	11
6.3.1 Division of test area.....	11
6.3.2 Wetting of the wall.....	11
6.3.3 Scrubbing.....	12
6.3.4 Determination of wet-scrub resistance properties.....	13
<b>7 Precision</b> .....	<b>14</b>
<b>8 Test report</b> .....	<b>15</b>
<b>Annex A (informative) Other types of stains used for evaluating stain removal performance of coatings</b> .....	<b>16</b>
<b>Annex B (informative) Effects of different sponges on cleanability test results</b> .....	<b>18</b>
<b>Annex C (informative) Repeatability of cleanability (stain removal) test</b> .....	<b>19</b>
<b>Bibliography</b> .....	<b>20</b>

## Foreword

ISO (the International Organization for Standardization) is a worldwide federation of national standards bodies (ISO member bodies). The work of preparing International Standards is normally carried out through ISO technical committees. Each member body interested in a subject for which a technical committee has been established has the right to be represented on that committee. International organizations, governmental and non-governmental, in liaison with ISO, also take part in the work. ISO collaborates closely with the International Electrotechnical Commission (IEC) on all matters of electrotechnical standardization.

The procedures used to develop this document and those intended for its further maintenance are described in the ISO/IEC Directives, Part 1. In particular, the different approval criteria needed for the different types of ISO documents should be noted. This document was drafted in accordance with the editorial rules of the ISO/IEC Directives, Part 2 (see [www.iso.org/directives](http://www.iso.org/directives)).

Attention is drawn to the possibility that some of the elements of this document may be the subject of patent rights. ISO shall not be held responsible for identifying any or all such patent rights. Details of any patent rights identified during the development of the document will be in the Introduction and/or on the ISO list of patent declarations received (see [www.iso.org/patents](http://www.iso.org/patents)).

Any trade name used in this document is information given for the convenience of users and does not constitute an endorsement.

For an explanation of the voluntary nature of standards, the meaning of ISO specific terms and expressions related to conformity assessment, as well as information about ISO's adherence to the World Trade Organization (WTO) principles in the Technical Barriers to Trade (TBT), see [www.iso.org/iso/foreword.html](http://www.iso.org/iso/foreword.html).

This document was prepared by Technical Committee ISO/TC 35, *Paints and varnishes*, Subcommittee SC 9, *General test methods for paints and varnishes*.

Any feedback or questions on this document should be directed to the user's national standards body. A complete listing of these bodies can be found at [www.iso.org/members.html](http://www.iso.org/members.html).

<https://standards.iteh.ai/catalog/standards/iso/b9251fe3-527a-4a4b-8322-d8de2d947029/iso-23169-2020>

## Introduction

Typical interior wall coating systems (see [Figure 1](#)) are comprised of a thick filler, one coat primer and two top coats. Thus, the quality of the final interior wall is dependent on the whole coating system from filler to primer to top coat. Besides, the quality of the application conditions, such as film thickness and paint-water dilution ratio, contribute to the final wall coating system significantly.

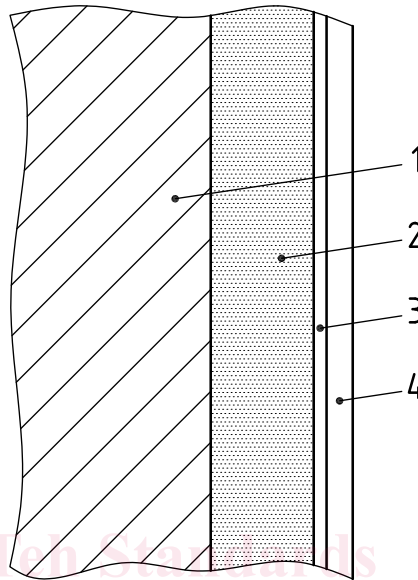

### Key

- 1 substrate (wall)
- 2 filler
- 3 primer (1 coat)
- 4 top coat (2 coats)

**Figure 1 — Typical interior wall coating system**

There is no standardized on-site test method on the market to check the performance of the whole system worldwide. Currently, so-called “on-site test methods” are relying on visual tests, on fingernail scrubbing and on touching. These methods are very subjective since results can vary from person to person, even for the same wall coating system and these results are not repeatable. As a result, this document provides standardized test methods for on-site wall coatings assessment. Using these standardized test methods could help distinguish between high-quality and low-quality interior wall coatings.



# Paints and varnishes — On-site test methods on quality assessment for interior wall coatings

## 1 Scope

This document specifies two on-site test methods (on-site cleanability [stain removal] and on-site wet-scrub resistance) for the evaluation of the quality assessment for interior wall coatings.

These test methods are applicable to white coatings and light-coloured coatings of tristimulus value  $Y_{10}$  greater than 25 measured on a test specimen consisting of a coating applied to a black substrate.

The cleanability test can differentiate the coating quality between 18 % of the pigment volume concentration (PVC) and the critical pigment volume concentration (CPVC). The on-site wet-scrub resistance test method can differentiate the coating quality when the PVC is nearly equal to the CPVC or above.

## 2 Normative references

The following documents are referred to in the text in such a way that some or all of their content constitutes requirements of this document. For dated references, only the edition cited applies. For undated references, the latest edition of the referenced document (including any amendments) applies.

ISO 3696, *Water for analytical laboratory use — Specification and test methods*

ISO 4618, *Paints and varnishes — Terms and definitions*

ISO 6504-3:2019, *Paints and varnishes — Determination of hiding power — Part 3: Determination of hiding power of paints for masonry, concrete and interior use*

ISO 13076, *Paints and varnishes — Lighting and procedure for visual assessments of coatings*

## 3 Terms and definitions

For the purposes of this document, the terms and definitions given in ISO 4618 and the following apply.

ISO and IEC maintain terminological databases for use in standardization at the following addresses:

- ISO Online browsing platform: available at <https://www.iso.org/obp>
- IEC Electropedia: available at <http://www.electropedia.org/>

### 3.1

#### paint-water dilution ratio

ratio of water to the paint, given as percentage by mass

### 3.2

#### light-coloured coating

coating with tristimulus values  $Y_{10}$  greater than 25, measured with a spectrophotometer on a test specimen consisting of a coating applied to a black substrate

Note 1 to entry: The test shall be in accordance with ISO 6504-3.

**3.3  
cleanability**

ability of a dry coating film to withstand penetration by soiling agents and to be freed from them through the cleaning process without removing more than a defined film thickness

[SOURCE: ISO 11998:2006, 3.1]

**3.4  
on-site wet-scrub resistance**

ability of a dry coating film to sustain less than a specified loss in film thickness, averaged over a defined area, when exposed to specified *wet-scrub cycles* (3.5)

Note 1 to entry: In ISO 11998, wet-scrub resistance is based on a lab test with 200 wet-scrub cycles.

**3.5  
scrub cycle**

one reciprocal movement of the scrub pad over the *scrub length* (3.6) in both directions

[SOURCE: ISO 11998:2006, 3.2]

**3.6  
scrub length**

*stroke length* (3.7) plus the length of the pad

[SOURCE: ISO 11998:2006, 3.3]

**3.7  
stroke length**

distance traversed by one stroke of the apparatus

[SOURCE: ISO 11998:2006, 3.4]

**4 Symbols**

$Y_{10}$	tristimulus value in accordance with CIE 1964 colour space
$Y_{10,u}$	tristimulus value of the untreated (index “u”) test stripe
$\bar{Y}_{10u,x}$	mean tristimulus value of the untreated (index “u”) test stripe $x$ ( $x = 1, 2$ and $3$ for respectively test stripes 1, 2 and 3)
$Y_{10,u,x,y}$	tristimulus value measured in untreated (index “u”) test stripe $x$ (for example $x = 1, 2$ and $3$ for respectively test stripes 1, 2 and 3 on test stripe 1) on point $y$ ( $y = 1, 2$ and $3$ for respectively measuring points 1, 2 and 3)
$Y_{10,t}$	tristimulus value of the treated (index “t”) test stripe
$\bar{Y}_{10,t,x}$	mean tristimulus value of the treated (index “t”) test stripe $x$ ( $x = 1, 2$ and $3$ for respectively test stripes 1, 2 and 3)
$Y_{10,t,x,y}$	tristimulus value measured in treated (index “t”) test stripe $x$ (for example $x = 1, 2$ and $3$ for respectively test stripes 1, 2 and 3 on test stripe 1) on point $y$ ( $y = 1, 2$ and $3$ for respectively measuring points 1, 2 and 3)
$C_{10}$	cleanability
$\bar{C}_{10}$	mean value for the cleanability
$\bar{C}_{10,x}$	mean cleanability for test stripe $x$ ( $x = 1, 2$ and $3$ for respectively test stripe 1, 2 and 3)



$\bar{C}_{10,w}$	mean cleanability of the water-soluble black solution (index “w”)
$\bar{C}_{10,a}$	mean cleanability of the alcohol soluble black solution (index “a”)
$\bar{C}_{10,v}$	mean cleanability of the table vinegar (index “v”)
$\bar{C}_{10,b}$	mean cleanability of the black tea (index “b”)
$\bar{C}_{10,k}$	mean cleanability of the blue-black ink (index “k”)
$R_a$	resistance class for an alcohol soluble black solution
$R_i$	resistance class for each tested soiling agent $i$
$R_s$	mean value of resistance against all tested soiling agents
$R_w$	resistance class for a water soluble black solution
$n$	number of soiling agents tested

## 5 On-site cleanability (stain removal) test

### 5.1 Principle

The standardized stains are applied on interior wall coatings and dried for 10 min. Then the cleanability test is run with the specified test apparatus (wet-scrub tester). The tristimulus value of the coating is measured before and after exposure.

### 5.2 Apparatus

#### 5.2.1 Wet-scrub tester.

The scrub testing machine is operated manually upwards and downwards with a stroke length of  $(180 \pm 10)$  mm and operating at approximately  $(20 \pm 1)$  scrub cycles per minute. The number of scrub cycles is recorded manually. Do not mix up the stroke length with the scrub length.

The apparatus for determination of cleanability and wet-scrub resistance of interior wall coatings is shown in [Figure 2](#). The apparatus can give consistent pressure and contact area when running the test through the below designs. Three wheels are used to control the track when running the test. The height of the wheel is designed to be lower than the height of sponge plus the black cloth, to ensure certain deformation and to provide a certain friction.

NOTE The force provided by the deformation of sponge has been determined by dynamic mechanical analysis (DMA) to be  $(2,6 \pm 0,2)$  N.

A sponge height of 15 mm is recommended to deliver the reasonable result. The contact area which is set by the location of the wheels is about 60 mm × 35 mm. The sponge (cleanability test) or the sponge covered by the black cloth (wet-scrub resistance test) is fixed by one balance bolt with two screws on each side. When the sponge is used under the black cloth, the purpose is to provide some damping when rubbing, not to bring extra damage to the coating due to the hardness of the main material. When determining “cleanability”, the black cloth does not need to be used; when determining “wet-scrub resistance”, the black cloth needs to be used.

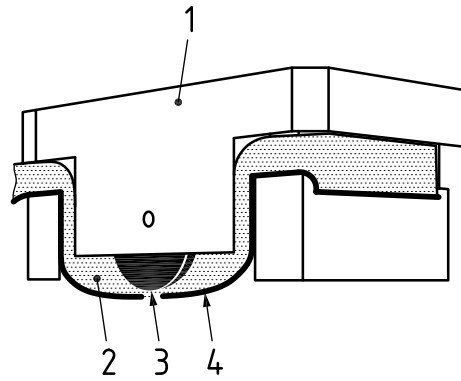

**Key**

- 1 main body
- 2 sponge
- 3 wheel
- 4 black cloth

**Figure 2 — Example of a wet-scrub tester**

**5.2.2 Spectrophotometer**, as specified in ISO 6504-3:2019, 6.5.

**5.2.3 Gauze**, of absorbent cotton.

**5.2.4 Adhesive tape**, with a width of 20 mm.

**5.2.5 Sponge**, with a size of 100 mm × 35 mm, a thickness of (15 ± 1) mm, a hardness of (55 ± 5) kPa and a density of (41 ± 2) kg/m<sup>3</sup>. For the effects of different sponges on cleanability test results, see [Annex B](#).

**5.2.6 Stirrer**, for preparing homogeneous solutions.

**5.2.7 Timer**.

**5.2.8 Lint-free tissues**.

**5.2.9 Blow drier**.

**5.3 Reagents**

**5.3.1 Cleaning medium for test**

Use a 2,5 g/l solution of sodium n-dodecylbenzenesulfonate (CAS-No 25155-30-0) in water in accordance with grade 3 of ISO 3696. Allow the solution to stand before use until all air-bubbles and foam have dissipated.

**5.3.2 Soiling agents**

**5.3.2.1 Water soluble black solution**

Put water in accordance with grade 3 of ISO 3696, into a vessel, then add Nigrosin black (CAS-No 8005-03-6), at a mass ratio of water : Nigrosin black of 97:3. Mix thoroughly till all the Nigrosin black is dissolved totally. Prepare this solution 24 h in advance before test. Its shelf life is seven days.