**Rolling bearings — Insert bearings
and eccentric locking collars —
Geometrical product specifications
(GPS) and tolerance values**

*Roulements — Roulements insert et bagues de blocage excentriques
— Spécification géométrique des produits (GPS) et valeurs de
tolérances*

ITeH standards
(<https://standards.iteh.ai>)
Document Preview

[ISO 9628:2019](https://standards.iteh.ai/catalog/standards/iso/d436b0b0-02b5-4553-8f79-92b0a8dfdb51/iso-9628-2019)

<https://standards.iteh.ai/catalog/standards/iso/d436b0b0-02b5-4553-8f79-92b0a8dfdb51/iso-9628-2019>



iTeh Standards
(<https://standards.iteh.ai>)
Document Preview

[ISO 9628:2019](https://standards.iteh.ai/catalog/standards/iso/d436b0b0-02b5-4553-8f79-92b0a8dfdb51/iso-9628-2019)

<https://standards.iteh.ai/catalog/standards/iso/d436b0b0-02b5-4553-8f79-92b0a8dfdb51/iso-9628-2019>



COPYRIGHT PROTECTED DOCUMENT

© ISO 2019

All rights reserved. Unless otherwise specified, or required in the context of its implementation, no part of this publication may be reproduced or utilized otherwise in any form or by any means, electronic or mechanical, including photocopying, or posting on the internet or an intranet, without prior written permission. Permission can be requested from either ISO at the address below or ISO's member body in the country of the requester.

ISO copyright office
CP 401 • Ch. de Blandonnet 8
CH-1214 Vernier, Geneva
Phone: +41 22 749 01 11
Fax: +41 22 749 09 47
Email: copyright@iso.org
Website: www.iso.org

Published in Switzerland

Contents

Page

Foreword	iv
Introduction	v
1 Scope	1
2 Normative references	1
3 Terms and definitions	1
4 Symbols	1
5 Characteristics and other specifications	8
5.1 General.....	8
5.2 Bore diameter.....	8
5.3 Outside diameter of bearing.....	8
5.4 Width of inner ring and locking device.....	9
5.5 Width of outer ring.....	9
5.6 Relubrication.....	9
6 Boundary dimensions	9
7 Tolerances	23
8 Radial internal clearances	24
Bibliography	29

iTech Standards
(<https://standards.iteh.ai>)
Document Preview

[ISO 9628:2019](https://standards.iteh.ai/catalog/standards/iso/d436b0b0-02b5-4553-8f79-92b0a8dfdb51/iso-9628-2019)

<https://standards.iteh.ai/catalog/standards/iso/d436b0b0-02b5-4553-8f79-92b0a8dfdb51/iso-9628-2019>

Foreword

ISO (the International Organization for Standardization) is a worldwide federation of national standards bodies (ISO member bodies). The work of preparing International Standards is normally carried out through ISO technical committees. Each member body interested in a subject for which a technical committee has been established has the right to be represented on that committee. International organizations, governmental and non-governmental, in liaison with ISO, also take part in the work. ISO collaborates closely with the International Electrotechnical Commission (IEC) on all matters of electrotechnical standardization.

The procedures used to develop this document and those intended for its further maintenance are described in the ISO/IEC Directives, Part 1. In particular the different approval criteria needed for the different types of ISO documents should be noted. This document was drafted in accordance with the editorial rules of the ISO/IEC Directives, Part 2 (see www.iso.org/directives).

Attention is drawn to the possibility that some of the elements of this document may be the subject of patent rights. ISO shall not be held responsible for identifying any or all such patent rights. Details of any patent rights identified during the development of the document will be in the Introduction and/or on the ISO list of patent declarations received (see www.iso.org/patents).

Any trade name used in this document is information given for the convenience of users and does not constitute an endorsement.

For an explanation on the voluntary nature of standards, the meaning of ISO specific terms and expressions related to conformity assessment, as well as information about ISO's adherence to the World Trade Organization (WTO) principles in the Technical Barriers to Trade (TBT) see the following URL: www.iso.org/iso/foreword.html.

This document was prepared by Technical Committee ISO/TC 4, *Rolling bearings*, Subcommittee SC 6, *Insert bearings*.

This third edition cancels and replaces the second edition (ISO 9628:2006), which has been technically revised. It also incorporates the Amendment ISO 9628:2006/Amd 1:2011.

The main changes compared to the previous edition are as follows:

- diameter series 3 has been included;
- the fractional expression “1-1/6” for 28,575 mm has been corrected to “1-1/8”;
- introduction of tolerance on D to get interchangeability among bearings from different manufactures;
- the geometrical product specification (GPS) system has been applied.

Any feedback or questions on this document should be directed to the user's national standards body. A complete listing of these bodies can be found at www.iso.org/members.html.

Introduction

This document is a machine element geometry standard as defined in the geometrical product specification (GPS) system presented in the matrix model of ISO 14638^[2].

The fundamental rules of ISO/GPS given in ISO 8015 apply to this document and the default decision rules given in ISO 14253-1^[5] apply to the specifications made in accordance with this document, unless otherwise indicated.

The connection between functional requirements, measuring technique and measuring uncertainty is always intended to be considered. The traditionally used measuring technique is described in ISO 1132-2^[3]. For measurement uncertainty, it is intended that ISO 14253-2^[6] be considered.

iTeh Standards
(<https://standards.itih.ai>)
Document Preview

[ISO 9628:2019](https://standards.itih.ai/catalog/standards/iso/d436b0b0-02b5-4553-8f79-92b0a8dfdb51/iso-9628-2019)

<https://standards.itih.ai/catalog/standards/iso/d436b0b0-02b5-4553-8f79-92b0a8dfdb51/iso-9628-2019>

Rolling bearings — Insert bearings and eccentric locking collars — Geometrical product specifications (GPS) and tolerance values

1 Scope

This document specifies the dimensional and geometrical characteristics, boundary dimensions and tolerances of insert bearings and eccentric locking collars and the radial internal clearances of insert bearings.

2 Normative references

The following documents are referred to in the text in such a way that some or all of their content constitutes requirements of this document. For dated references, only the edition cited applies. For undated references, the latest edition of the referenced document (including any amendments) applies.

ISO 1101, *Geometrical product specifications (GPS) — Geometrical tolerancing — Tolerances of form, orientation, location and run-out*

ISO 1132-1, *Rolling bearings — Tolerances — Part 1: Terms and definitions*

ISO 5593, *Rolling bearings — Vocabulary*

ISO 8015, *Geometrical product specifications (GPS) — Fundamentals — Concepts, principles and rules*

ISO 14405-1, *Geometrical product specifications (GPS) — Dimensional tolerancing — Part 1: Linear sizes*

3 Terms and definitions

For the purposes of this document, the terms and definitions given in ISO 1101, ISO 1132-1, ISO 5593 and ISO 14405-1 and the following apply.

ISO and IEC maintain terminological databases for use in standardization at the following addresses:

- ISO Online browsing platform: available at <https://www.iso.org/obp>
- IEC Electropedia: available at <http://www.electropedia.org/>

3.1

insert bearing

radial rolling bearing with a spherical outside surface and an extended inner ring with a locking device

Note 1 to entry: The locking device, used for fixing the inner ring to the shaft, may be an eccentric locking collar or set screws either in a concentric locking collar around the inner ring or directly in the inner ring.





4 Symbols

ISO 8015 shall be applied and the dimensional and geometrical characteristics shall be included in the technical product documentation (for example, on the drawing). The dimensional specifications associated to these characteristics are described in [Table 1](#).

In this document, the ISO default specification operator for size is in accordance with ISO 14405-1, i.e. the two-point size is valid.

NOTE Figures 1 to 6 are drawn schematically and sealing devices and cages are not shown in Figures 1 to 4. A tolerance value and width of tolerance zone associated to a characteristic is symbolised by t followed by the symbol for the characteristic, for example $t_{Vd_{sp}}$ or t_{A1} .

Table 1 — Symbols for nominal sizes, dimension limits, characteristics and specification modifiers

Symbol for nominal dimension. (size and distance) ^a	Symbol for characteristic ^a	GPS symbol and specification modifier ^{b,c}	Description ^d	See Figure
A		min.	lower limit distance between the face and the end face of eccentric surface of inner ring	Figure 5
A_1	$A1$		position of the end face of eccentric surface at distance “A1” with respect to the small face of eccentric locking collar	
B			nominal width of inner ring	Figures 2 and 3
		max.	upper limit width of inner ring	
B_1			nominal width of inner ring and eccentric collar in combination	Figure 1
		max. 	upper limit width of inner ring and eccentric collar in combination	
B_2	$\Delta B2s$		nominal width of eccentric collar	Figure 6
			upper limit: deviation of a minimum circumscribed size of eccentric collar width, between two opposite lines, in any longitudinal section which includes the eccentric collar bore axis	
			lower limit: deviation of a two-point size of eccentric collar width	
C			nominal width of outer ring	Figures 1, 2, 3 and 4
C_1			nominal distance from the middle plane of outer ring width to the center of lubrication zone	Figure 1
C_2			nominal width of lubrication zone	Figure 1
D			nominal outside diameter of bearing (diameter of spherical outer surface of outer ring)	Figures 1, 2, 3 and 4
	ΔDm		deviation of a midrange size (out of two-point sizes) of spherical outer surface diameter	Figures 1, 2, 3 and 4

^a Symbols as defined in ISO 15241^[8] except for the format used.

^b Symbols as defined in ISO 1101 and ISO 14405-1.

^c Specification modifier LP shall not be indicated on a drawing, if the two-point size is applied for both specified limits.

^d Description based on ISO 1101, ISO 5459^[4] and ISO 14405-1.

Table 1 (continued)

Symbol for nominal dimension. (size and distance) ^a	Symbol for characteristic ^a	GPS symbol and specification modifier ^{b,c}	Description ^d	See Figure
d			nominal bore diameter of inner ring or of eccentric locking collar	Figures 1, 2, 3, 4, 5 and 6
	Δd_{mp}	$\textcircled{\text{LP}} \textcircled{\text{SD}} \text{ACS}$	deviation of a midrange size (out of two-point sizes) of inner ring bore diameter in any cross-section	Figures 1, 2, 3 and 4
	V_{dsp}	$\textcircled{\text{LP}} \textcircled{\text{SR}} \text{ACS}$	range of two-point sizes of inner ring bore diameter in any cross-section	
	Δd_s	$\textcircled{\text{LP}}$	deviation of a two-point size of eccentric collar bore diameter	Figure 6
d_1			nominal outside diameter of eccentric locking collar	Figure 6
		max.	upper limit outside diameter of eccentric locking collar	
d_2			nominal small bore diameter of eccentric surface (at theoretical sharp corner) of eccentric locking collar	Figure 6
	Δd_{2s}	$\textcircled{\text{LP}}$	deviation of a two-point size of small bore diameter of eccentric surface (at theoretical sharp corner) of eccentric locking collar	
d_3			nominal large outside diameter of eccentric surface (at theoretical sharp corner) of inner ring	Figure 5
		max.	upper limit large outside diameter of eccentric surface (at theoretical sharp corner) of inner ring	
H			nominal eccentricity of inner ring eccentric extension and of eccentric locking collar	Figures 5 and 6
	H	$\textcircled{\text{LP}}$	position of eccentricity of eccentric extension of inner ring or eccentric locking collar at distance H with respect to datum (i.e. axis established from bore surface of inner ring) or datum (i.e. axis established from bore surface of eccentric locking collar)	
r_1			nominal chamfer dimension of eccentric surface of inner ring	Figure 5
r_2			nominal fillet radius of eccentric surface of inner ring	Figure 5
r_3			nominal fillet radius of eccentric surface of eccentric locking collar	Figure 6
r_4			nominal chamfer dimension of eccentric surface of eccentric locking collar	Figure 6

^a Symbols as defined in ISO 15241^[8] except for the format used.

^b Symbols as defined in ISO 1101 and ISO 14405-1.

^c Specification modifier LP shall not be indicated on a drawing, if the two-point size is applied for both specified limits.

^d Description based on ISO 1101, ISO 5459^[4] and ISO 14405-1.

Table 1 (continued)

Symbol for nominal dimension. (size and distance) ^a	Symbol for characteristic ^a	GPS symbol and specification modifier ^{b,c}	Description ^d	See Figure
S			nominal distance from the middle plane of outer ring width to the face of inner ring on side opposite locking device (auxiliary dimension)	Figures 1, 2, 3 and 4
S_1			nominal distance from the middle plane of outer ring width to face of inner ring or eccentric locking collar limiting overall bearing width on locking device side	Figures 1, 2, 3 and 4

^a Symbols as defined in ISO 15241[8] except for the format used.
^b Symbols as defined in ISO 1101 and ISO 14405-1.
^c Specification modifier LP shall not be indicated on a drawing, if the two-point size is applied for both specified limits.
^d Description based on ISO 1101, ISO 5459[4] and ISO 14405-1.

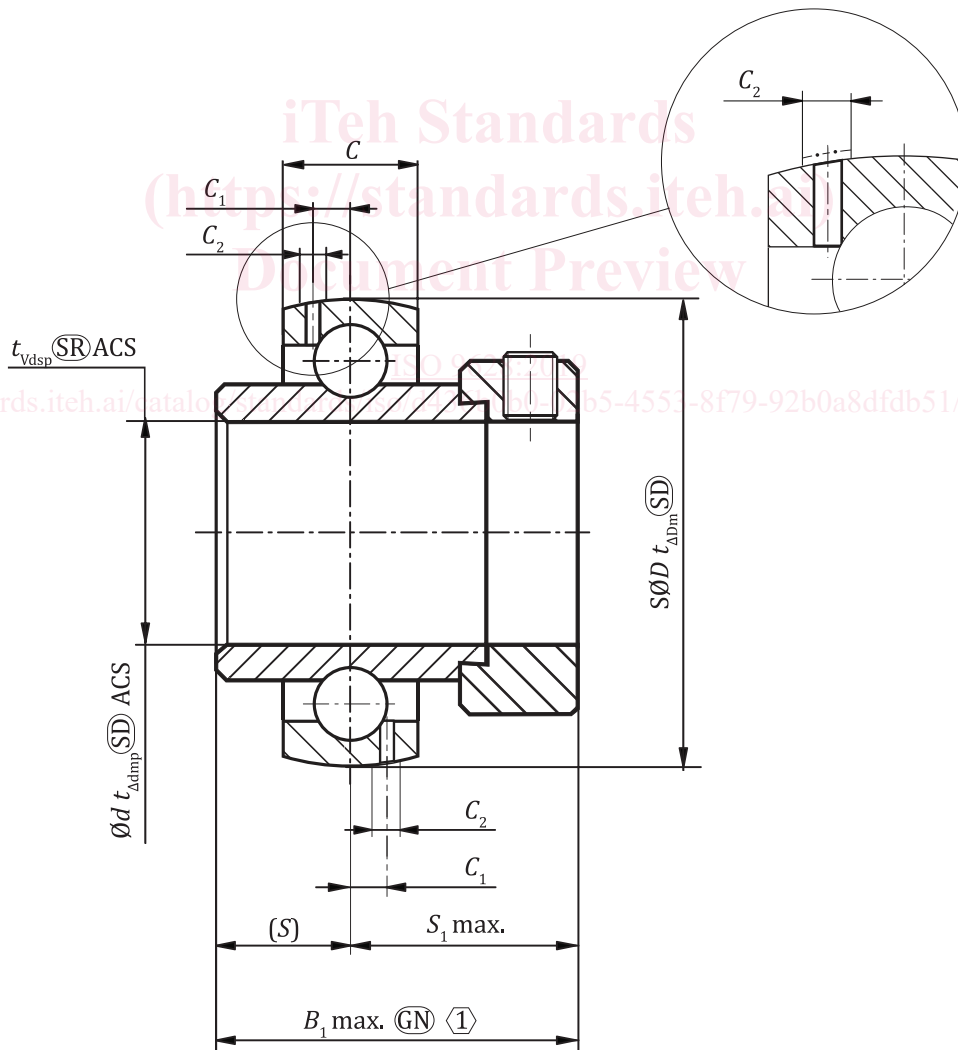

(1) the inner ring shall be in contact with the eccentric locking collar

Figure 1 — Bearing with eccentric locking collar — Wide overall width

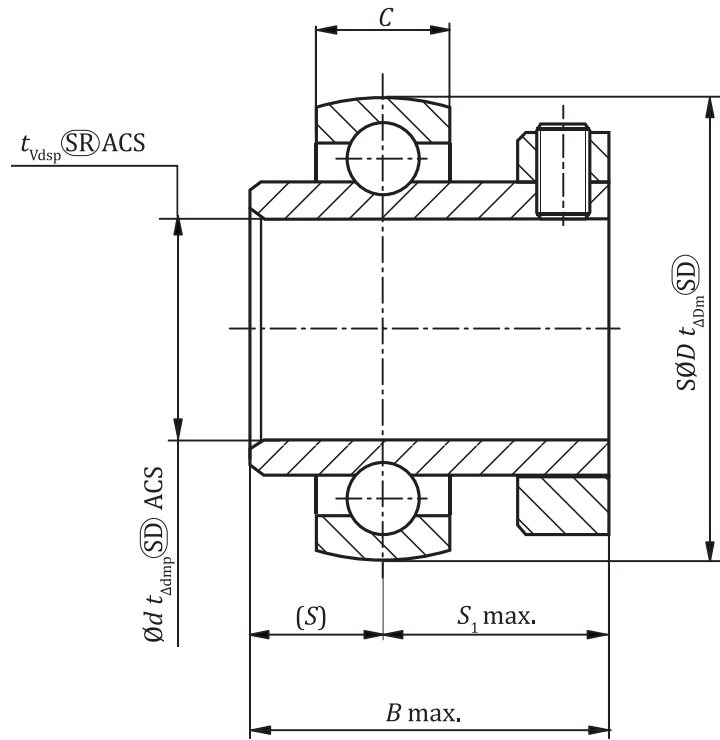

Figure 2 — Bearing with concentric locking collars around the inner ring — Intermediate overall width

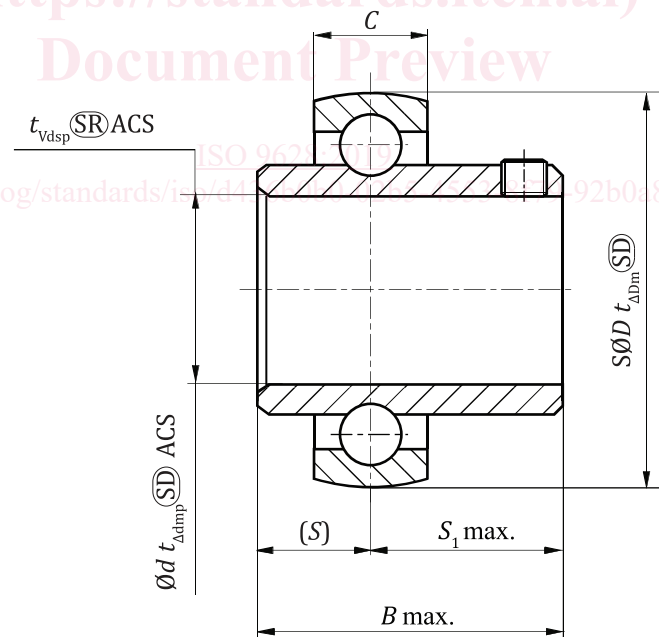

Figure 3 — Bearing with set screws in the inner ring — Intermediate overall width