



Designation: ~~D7466-08~~ Designation: D7466 – 10

Standard Test Method for Measuring the Asperity Height of Textured Geomembranes¹

This standard is issued under the fixed designation D7466; the number immediately following the designation indicates the year of original adoption or, in the case of revision, the year of last revision. A number in parentheses indicates the year of last reapproval. A superscript epsilon (ϵ) indicates an editorial change since the last revision or reapproval.

1. Scope

1.1 This test method covers a procedure to measure the asperity height of textured geomembranes.

1.2 This test method does not provide for measurement of the spacing between the asperities nor of the complete profile of the textured surface.

1.3 *This standard does not purport to address all of the safety concerns, if any, associated with its use. It is the responsibility of the user of this standard to establish appropriate safety and health practices and determine the applicability of regulatory limitations prior to use.*

2. Referenced Documents

2.1 *ASTM Standards:*²

D4439 [Terminology for Geosynthetics](#)

~~D5994 [Test Method for Measuring Core Thickness of Textured Geomembrane](#)~~ [Test Method for Measuring Core Thickness of Textured Geomembrane](#)

E177 [Practice for Use of the Terms Precision and Bias in ASTM Test Methods](#)

E691 [Practice for Conducting an Interlaboratory Study to Determine the Precision of a Test Method](#)

E2554 [Practice for Estimating and Monitoring the Uncertainty of Test Results of a Test Method in a Single Laboratory Using a Control Sample Program](#)

3. Terminology

~~3.1~~

~~3.1~~ For definitions of other terms used in this test method, refer to Terminology D4439.

~~3.2~~ *Definitions:*

~~3.1.1~~

~~3.2.1~~ *asperity, n*—the individual projections of polyethylene that extend above the core surface of a textured geomembrane resulting in the textured surface profile.

~~3.1.2~~ *core thickness,*

~~3.2.2~~ *core thickness, n*—the average thickness of a textured geomembrane as measured using Test Method D5994.

~~3.1.3~~ *geomembrane)*

~~3.2.3~~ *geomembrane, n*—an essentially impermeable geosynthetic composed of one or more synthetic sheets. ~~D4439~~

~~3.1.4~~ *thickness gage contact point, n*—the tip of a thickness gage which contacts the base sheet of the geomembrane surface.

~~3.1.5~~

~~3.2.4~~ *setting block, n*—the component part of a depth gauge that rests on top of the asperities.

~~3.1.6~~ ~~3.2.5~~ *thickness, n*— the perpendicular distance between one surface and its opposite.

~~3.2~~ For definitions of other terms used in this test method, refer to Terminology D4439.

~~3.2.6~~ *thickness gage contact point, n*—the tip of a thickness gauge which contacts the base sheet of the geomembrane surface.

D4439

4. Summary of Test Method

4.1 The asperity height of a textured geomembrane is measured with a depth gauge, the setting block of which rests on the top of the asperities while the contact point extends to the sheet's core surface.

4.2 The asperity height of a textured geomembrane is calculated as the average value of ten (10) individual measurements taken

¹ This test method is under the jurisdiction of ASTM Committee D35 on Geosynthetics and is the direct responsibility of Subcommittee D35.10 on Geomembranes.

Current edition approved July 1, 2008. Published August 2008. DOI: 10.1520/D7466-08.

Current edition approved July 1, 2010. Published September 2010. Originally approved in 2008. Last previous edition approved in 2008 as D7466-08. DOI: 10.1520/D7466-10.

² For referenced ASTM standards, visit the ASTM website, www.astm.org, or contact ASTM Customer Service at service@astm.org. For *Annual Book of ASTM Standards* volume information, refer to the standard's Document Summary page on the ASTM website.

across the roll width of the sample under investigation.

5. Significance and Use

5.1 The asperity height is an index property used to quantify one of the physical attributes related to the surface roughness of textured geomembranes.

5.2 This test method is applicable to all currently available textured geomembranes that are deployed as manufactured geomembrane sheets.

6. Apparatus

6.1 *Depth Gauge*—~~The~~—The depth gauge shall consist of three components that conform the requirements of this section; a dial indicator, a setting block and a contact point with extension.

6.1.1 *Dial Indicator*—~~capable~~—capable of measuring to depth of at least 2.5 mm (0.10 in.) with an accuracy of ± 0.025 mm (0.001 in.).

6.1.2 *Setting Block*—the setting block shall have a base dimension of 50 mm to 63.5 mm long ~~by~~ 20 mm to 12.7 mm wide (2.0 in. to 2.5 in. long ~~by~~ 0.75 in. to 0.50 in. wide) and a height of 15 mm (0.60 in.).

6.1.3 *Contact Point with Extension*—~~The~~—The contact point is 1.3 mm (0.051 in.) in diameter with the tip tapered to a point. An extension of approximately 17 mm (0.66 in.) is required to achieve the necessary travel beyond the base surface of the setting block. The contact point should protrude at least 10 mm below the setting block when not in use in order to ensure that a competent “zero” setting is achieved. See Fig. 1, Fig. 2, and Fig. Figs. 1-3.

6.1.4 ~~The mass of the depth gauge fully assembled with the dial indicator, setting block, contact point with extension should not exceed 300 grams.~~

NOTE 1—Depth gages of the type described above are manufactured by Chicago Dial Indicator, Inc., B.C. Ames Company and Federal Instruments.

6.1.4 The mass of the depth gauge fully assembled with the dial indicator, setting block, contact point with extension should not exceed 300 g.

7. Sampling

7.1 *Sample*—For the sample, take a full width sample at least 75-mm (3-in.) wide. Exclude the inner and outer wraps of the roll or any material not representative of the sample. Either the entire strip may be tested or individual test specimens may be taken from this sample, with a minimum diameter of 75 mm (3-in.); (3 in.), spaced such that a total of ten (10) asperity height determinations will be made approximately evenly across the sample.

7.2 *Sample Labeling*—For textured geomembrane samples that are textured on both sides, identify one surface as “Side A” and the other as “Side B”. Side A should correspond to the outside surface of the product when on the parent roll, and Side B the inside surface whenever this relationship is known. known. [ASTM D7466-10](https://standards.iteh.ai/catalog/standards/sist/a9e2877f-c670-4704-a17f-6d188e5a1615/astm-d7466-10)

8. Conditioning and Testing

8.1 Bring the specimens to temperature equilibrium at $21 \pm 2^\circ\text{C}$ ($70 \pm 4^\circ\text{F}$) and at a relative humidity of $60 \pm 10\%$.

9. Procedure

9.1 Test the conditioned specimens in the standard laboratory atmosphere specified in 8.1.

9.2 Place the depth gauge on a flat, rigid supporting surface to zero the contact point with the bottom of the setting block.

9.3 Place the geomembrane specimen being tested on a flat, rigid, supporting surface being vigilant to keep the specimen flat for the measurements. For two side textured geomembranes, measure the asperity height of Side A first.

9.4 Place the depth gauge on the surface of the textured geomembrane specimen, with the long axis of the setting block perpendicular to the machine direction of the roll. Do not to apply downward hand pressure on the gauge as this would compress

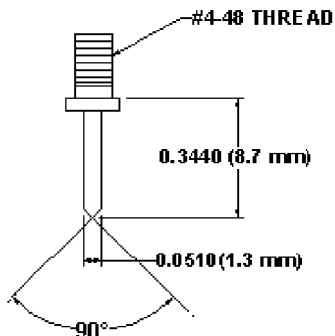

FIG. 2 Contact Point