

---

---

## Alpine ski-boots — Requirements and test methods

*Chaussures de ski pour skis alpins — Exigences et méthodes d'essai*

**iTeh STANDARD PREVIEW**  
**(standards.iteh.ai)**

[ISO 5355:2019](https://standards.iteh.ai/catalog/standards/sist/5d9e2d8e-097d-424b-ace4-65c363c0bb98/iso-5355-2019)

<https://standards.iteh.ai/catalog/standards/sist/5d9e2d8e-097d-424b-ace4-65c363c0bb98/iso-5355-2019>



**iTeh STANDARD PREVIEW**  
**(standards.iteh.ai)**

ISO 5355:2019

<https://standards.iteh.ai/catalog/standards/sist/5d9e2d8e-097d-424b-ace4-65c363c0bb98/iso-5355-2019>



**COPYRIGHT PROTECTED DOCUMENT**

© ISO 2019

All rights reserved. Unless otherwise specified, or required in the context of its implementation, no part of this publication may be reproduced or utilized otherwise in any form or by any means, electronic or mechanical, including photocopying, or posting on the internet or an intranet, without prior written permission. Permission can be requested from either ISO at the address below or ISO's member body in the country of the requester.

ISO copyright office  
CP 401 • Ch. de Blandonnet 8  
CH-1214 Vernier, Geneva  
Phone: +41 22 749 01 11  
Fax: +41 22 749 09 47  
Email: [copyright@iso.org](mailto:copyright@iso.org)  
Website: [www.iso.org](http://www.iso.org)

Published in Switzerland

# Contents

	Page
Foreword .....	iv
<b>1 Scope .....</b>	<b>1</b>
<b>2 Normative references .....</b>	<b>1</b>
<b>3 Terms and definitions .....</b>	<b>1</b>
<b>4 Requirements and test methods .....</b>	<b>2</b>
4.1 General .....	2
4.2 Dimensions .....	2
4.2.1 Requirements .....	2
4.2.2 Testing of evenness .....	5
4.3 Design .....	7
4.3.1 Sole length .....	7
4.3.2 Symmetry .....	7
4.3.3 Side walls at boot toe .....	7
4.3.4 Side walls at boot heel .....	7
4.3.5 Free spaces .....	9
4.3.6 Interfaces .....	16
4.3.7 Bevelled areas .....	18
4.3.8 Bearing surface at heel .....	19
4.3.9 Low-friction zone .....	24
4.3.10 Style of boot shell .....	26
4.3.11 Mounting point .....	26
4.3.12 Sole length .....	27
<b>5 Marking .....</b>	<b>27</b>
<b>6 Information supplied by the manufacturer .....</b>	<b>27</b>
6.1 General .....	27
6.2 User manual .....	27
<b>Annex A (informative) Mondopoint system ski-boot sizing and marking .....</b>	<b>28</b>
<b>Annex B (informative) Dimensions and requirements of “2<sup>nd</sup> degree” .....</b>	<b>29</b>

## Foreword

ISO (the International Organization for Standardization) is a worldwide federation of national standards bodies (ISO member bodies). The work of preparing International Standards is normally carried out through ISO technical committees. Each member body interested in a subject for which a technical committee has been established has the right to be represented on that committee. International organizations, governmental and non-governmental, in liaison with ISO, also take part in the work. ISO collaborates closely with the International Electrotechnical Commission (IEC) on all matters of electrotechnical standardization.

The procedures used to develop this document and those intended for its further maintenance are described in the ISO/IEC Directives, Part 1. In particular, the different approval criteria needed for the different types of ISO documents should be noted. This document was drafted in accordance with the editorial rules of the ISO/IEC Directives, Part 2 (see [www.iso.org/directives](http://www.iso.org/directives)).

Attention is drawn to the possibility that some of the elements of this document may be the subject of patent rights. ISO shall not be held responsible for identifying any or all such patent rights. Details of any patent rights identified during the development of the document will be in the Introduction and/or on the ISO list of patent declarations received (see [www.iso.org/patents](http://www.iso.org/patents)).

Any trade name used in this document is information given for the convenience of users and does not constitute an endorsement.

For an explanation of the voluntary nature of standards, the meaning of ISO specific terms and expressions related to conformity assessment, as well as information about ISO's adherence to the World Trade Organization (WTO) principles in the Technical Barriers to Trade (TBT) see [www.iso.org/iso/foreword.html](http://www.iso.org/iso/foreword.html).

ISO 5355 was prepared by Technical Committee ISO/TC 83, *Sports and other recreational facilities and equipment*, Subcommittee SC 4, *Snowsports equipment*.

This fifth edition cancels and replaces the fourth edition (ISO 5355:2005 and ISO 5355/Cor.1:2007), which has been technically revised. The main changes compared to the previous edition are as follows:

- new definition of material properties of a PTFE to test the dynamic friction of boot materials in [4.3.9.2.2](#);
- new clause 6 "information supplied by the manufacturer";
- added tolerance for sole length marking in [4.3.12](#).

Any feedback or questions on this document should be directed to the user's national standards body. A complete listing of these bodies can be found at [www.iso.org/members.html](http://www.iso.org/members.html).

# Alpine ski-boots — Requirements and test methods

## 1 Scope

This document specifies the requirements, test methods and marking of ski-boots which are used with current systems of alpine ski-bindings with attachment at the boot toe and boot heel, the proper release function of which depends on the dimensions and design of the interfaces.

For ski-binding systems that function irrespective of the sole shape or that have different requirements for the sole dimensions, it is not always necessary for the ski-boot soles to comply with this document in order to achieve the desired degree of safety.

It applies to ski-boots of sizes 15,0 and larger [types A (for adults) and C (for children)] in the Mondopoint system (see [Annex A](#)).

## 2 Normative references

The following documents are referred to in the text in such a way that some or all of their content constitutes requirements of this document. For dated references, only the edition cited applies. For undated references, the latest edition of the referenced document (including any amendments) applies.

ISO 527-1, *Plastics — Determination of tensile properties — Part 1: General principle*

ISO 527-2, *Plastics — Determination of tensile properties — Part 2: Test conditions for moulding and extrusion plastics*

ISO 554, *Standard atmospheres for conditioning and/or testing — Specifications*

ISO 868, *Plastics and ebonite — Determination of indentation hardness by means of a durometer (Shore hardness)*

ISO 1183 (all parts), *Plastics — Methods for determining the density of non-cellular plastics*

ISO 2039-1, *Plastics — Determination of hardness — Part 1: Ball indentation method*

ISO 9407, *Shoe sizes — Mondopoint system of sizing and marking*

ISO 9462, *Alpine ski-bindings — Requirements and test methods*

ISO 13992, *Alpine touring ski-bindings — Requirements and test methods*

## 3 Terms and definitions

For the purposes of this document, the following terms and definitions apply.

ISO and IEC maintain terminological databases for use in standardization at the following addresses:

- ISO Online browsing platform: available at <https://www.iso.org/obp>
- IEC Electropedia: available at <http://www.electropedia.org/>

### 3.1

#### interface

part of the ski-boot intended to contact with the ski-binding

**3.2**

**front interface**

part of the ski-boot intended to contact with the front binding

**3.3**

**rear interface**

part of the ski-boot intended to contact with the rear binding

**3.4**

**free space**

space intended to avoid contact between ski-boot and binding, especially during step in/step out or release

**3.5**

**median plane**

middle plane of the sole, longitudinal and perpendicular to the bearing surface

**3.6**

**bearing surfaces**

front and rear surfaces of the boot sole which are in contact with a plane on which the boot is standing

**3.7**

**ski-brake**

device to stop the ski after release of the binding

**4 Requirements and test methods**

ITeH STANDARD PREVIEW  
(standards.iteh.ai)

**4.1 General**

If no specific test methods are indicated, check the characteristics as appropriate, e.g. by measurement.

If not otherwise indicated, execute the testing under standard atmosphere 23/50 (see ISO 554) with ordinary tolerances.

**4.2 Dimensions**

**4.2.1 Requirements**

The boot toe and heel shall comply with [Figures 1](#) and [2](#). Other boot dimensions need not correspond to the figures.

Fundamentally, all dimensions shall be within the indicated tolerances. However, relevance to safety varies in importance depending on the indicated dimensions.

Looking at several dimensions (“dimensions of the 2nd degree”) deviations may be accepted, provided that the following requirements are respected.

- a) The deviations shall remain exceptional.
- b) The deviations are small.
- c) No limitations of function arise with all marketable and critical bindings.
- d) The tolerances are respected at the next possible opportunity (e.g. reconstruction of a tool).

See [Annex B](#).

Dimensions in millimetres

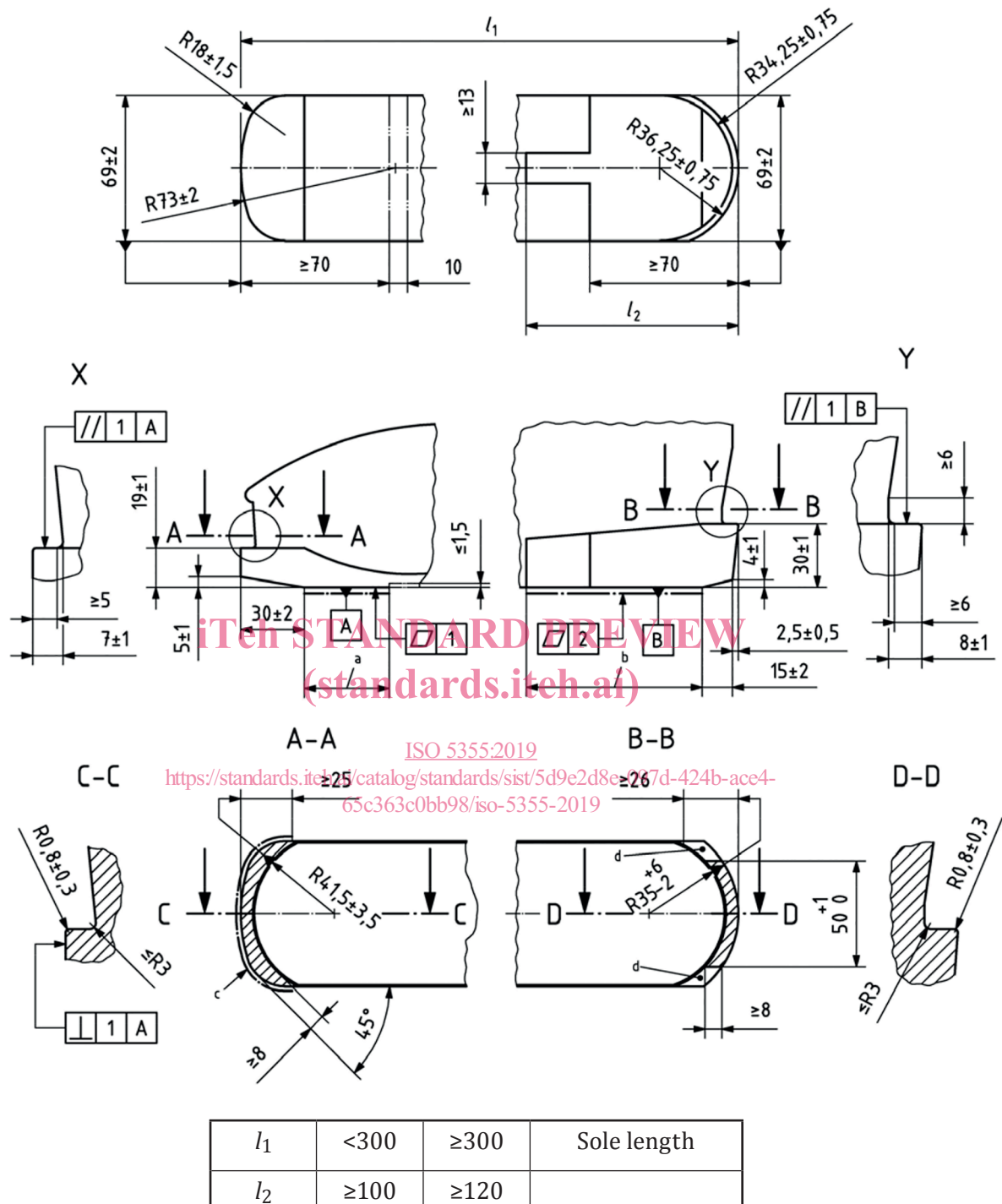

- a Low-friction zone/bearing surface.
- b Bearing surface (see 3.6).
- c Area in which the tolerance of perpendicularity is valid (see 4.3.3).
- d Reserved areas for adjustment device.

NOTE Shaded areas including areas with index<sup>d</sup> are those in which the tolerances of evenness and the dimensions (19 ± 1) mm and (30 ± 1) mm are valid.

Figure 1 — Dimensions of boot toe and heel, type A

Dimensions in millimetres

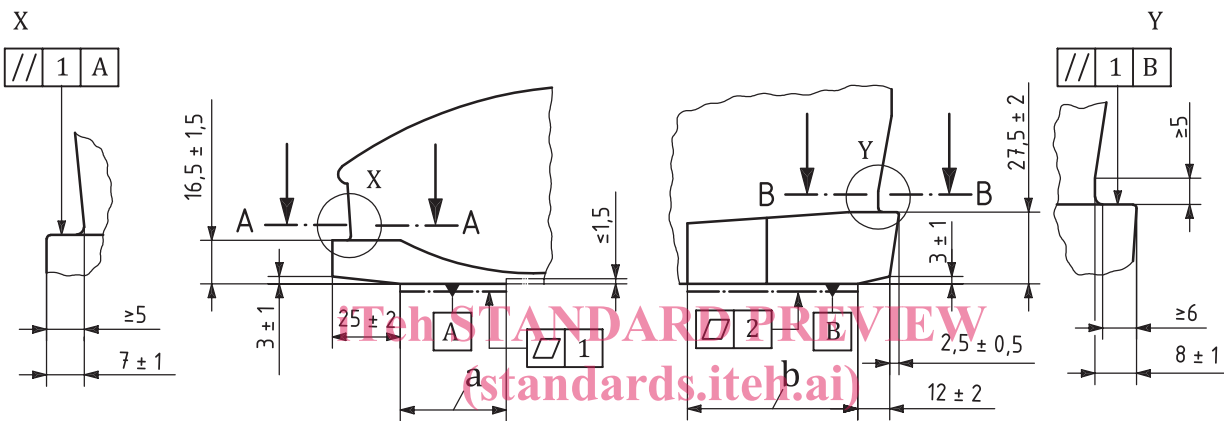
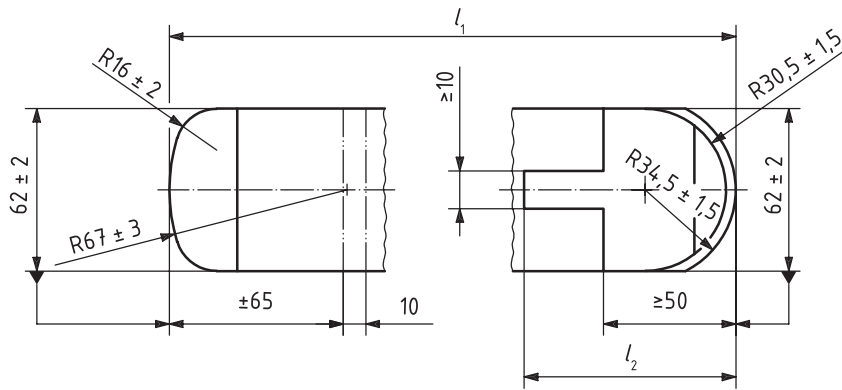

ISO 5355:2019

<https://standards.iteh.ai/catalog/standards/sist/5d9e238e-067d-424b-ace4-65c363c0bb98/iso-5355-2019>

A - A B - B

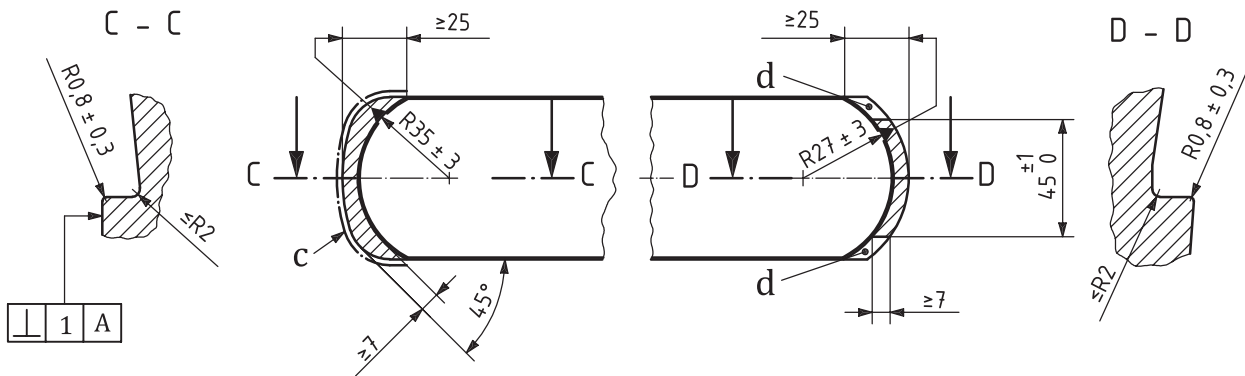



$l_1$	<240	≥240	Sole length
$l_2$	≥80	≥90	

- a Low-friction zone/bearing surface.
- b Bearing surface (see 3.6).
- c Area in which the tolerance of perpendicularity is valid (see 4.3.3).
- d Reserved areas for adjustment device.

NOTE Shaded areas including areas with index<sup>d</sup> are those in which the tolerances of evenness and the dimensions ( $16,5 \pm 1,5$ ) mm and ( $27,5 \pm 2$ ) mm are valid.

**Figure 2 — Dimensions of boot toe and heel, type C**

#### 4.2.2 Testing of evenness

**4.2.2.1** When the front bearing surface rests on a plane, a gauge 1 mm thick and 10 mm wide shall not enter the AB area at any point. See Figure 3.

**4.2.2.2** When the rear bearing surface rests on a plane, a gauge 1 mm thick and 10 mm wide shall not enter the CD area at any point. See Figure 4.

**4.2.2.3** Before measuring the evenness of the bearing surfaces as described in Figure 5, apply a load of

— type A: 100 N;

— type C: 50 N <https://standards.iteh.ai/catalog/standards/sist/5d9e2d8e-097d-424b-ace4-65c363c0bb98/iso-5355-2019>

by inserting into the ski-boot itself a steel cylinder with a diameter of

— type A: 80 mm;

— type C: 50 mm

the ends rounded with a 10 mm radius and having a corresponding mass. After 5 min, determine the flatness measurement as follows.

When the boot rests on the test plane (see Figure 5), check the maximum thickness of a 10 mm wide gauge which can enter the BC area anywhere (to a maximum of 2 mm). This gauge shall not enter the AB and CD areas.

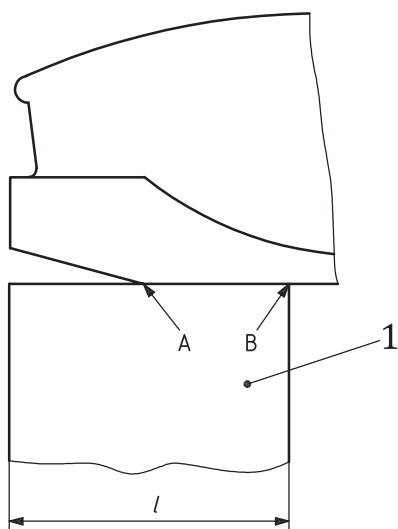

Dimension	Type	
	A	C
<i>l</i>	70	65

**Key**  
1 test plane

**iTeh STANDARD PREVIEW**  
(standards.iteh.ai)

**Figure 3 — Testing of evenness at the front**

ISO 5355:2019  
<https://standards.iteh.ai/catalog/standards/sist/5d9e2d8e-097d-424b-ace4-65c363c0bb98/iso-5355-2019>  
 Dimensions in millimetres

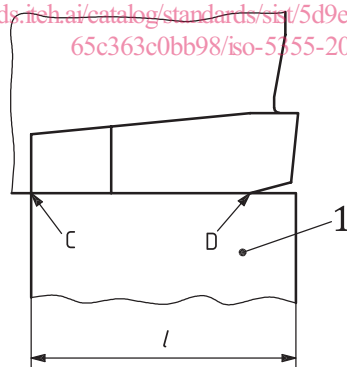

Dimension	Type	
	A	C
<i>l</i>	100	80

**Key**  
1 test plane

**Figure 4 — Testing of evenness at the rear**

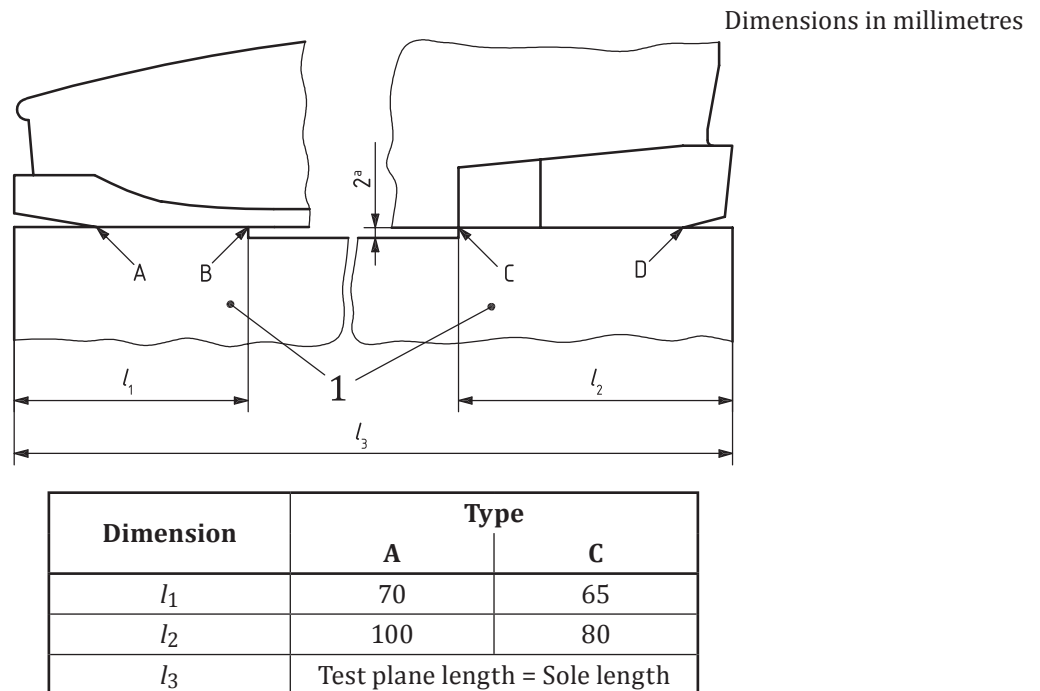
**Key**

- 1 test plane  
a Cut-out in the test surface.

**STANDARD PREVIEW**  
(standards.iteh.ai)

**Figure 5 — Testing of evenness of the whole boot**

[ISO 5355:2019](https://standards.iteh.ai/catalog/standards/sist/5d9e2d8e-097d-424b-ace4-65c363c0bb98/iso-5355-2019)

<https://standards.iteh.ai/catalog/standards/sist/5d9e2d8e-097d-424b-ace4-65c363c0bb98/iso-5355-2019>

**4.3 Design****4.3.1 Sole length**

The sole lengths of the two ski-boots in a pair shall not differ by more than 2 mm.

**4.3.2 Symmetry**

The sole dimensions in the toe and heel interface areas shall be symmetrical about the median plane within an admissible deviation of 1 mm.

**4.3.3 Side walls at boot toe**

The side walls of the sole at the boot toe, up to a distance of at least 25 mm from the toe end, shall be perpendicular to the bearing surface within an admissible inward-outward deviation of 1 mm.

If the side walls of the sole are built in two parts, it shall be ensured that no part of the lower area of the sole protrudes beyond the upper profile.

**4.3.4 Side walls at boot heel**

The lateral side walls of the sole at the boot heel, up to a distance of at least

- type A: 70 mm;
- type C: 50 mm

from the heel end, shall be perpendicular to the bearing surface, or tapered inwards — outwards between 0° and 10° up to a height of 14 mm.

No part of the sole shall project beyond the 10° side wall limitation up to a height of 14 mm, between

- type A: 70 mm and 85 mm;
- type C: 50 mm and 65 mm.

If lateral grooves of more than 2 mm depth are present at the heel, see [Figure 6](#), supports at least complying with [Figure 7](#) shall remain.

Other configurations of grooves are allowed if they are within the given dimensions in [Figure 6](#) and [Figure 7](#).

Dimensions in millimetres

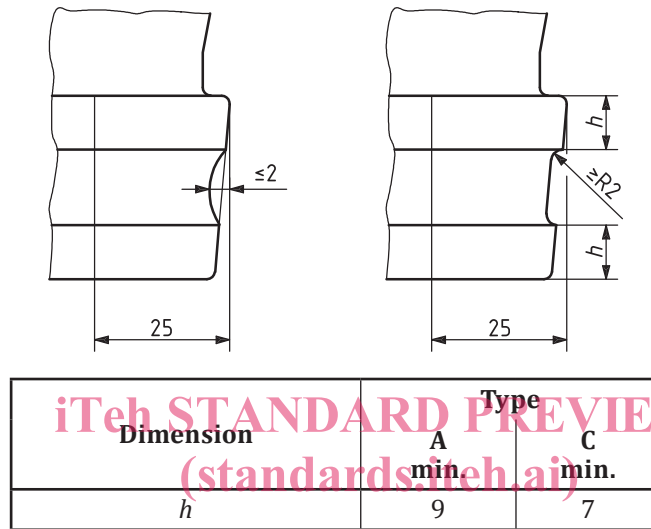

ISO 5355:2019  
<https://standards.iteh.ai/catalog/standards/iso/5355-2019/97d-424b-ace4-65c363c0bb98/iso-5355-2019>  
**Figure 6 — Lateral grooves at heel**