



Designation: D7226 – 06^{e1}

Standard Test Method for Determining the Viscosity of Emulsified Asphalts Using a Rotational Paddle Viscometer¹

This standard is issued under the fixed designation D7226; the number immediately following the designation indicates the year of original adoption or, in the case of revision, the year of last revision. A number in parentheses indicates the year of last reapproval. A superscript epsilon (ϵ) indicates an editorial change since the last revision or reapproval.

^{e1} NOTE—Added research report information to Section 9 editorially in September 2010.

1. Scope

1.1 This test method uses a paddle rotational viscometer to measure the apparent viscosity of emulsified asphalt with viscosities between 30 and 1500 mPa·s (centipoises) at 50°C (122°F). It is applicable to all emulsified asphalt described in Specifications D977 and D2397.

1.2 The values given in SI units are to be considered the standard. The values given in parentheses are for information only.

1.3 *This standard does not purport to address all of the safety concerns, if any, associated with its use. It is the responsibility of the user of this standard to establish appropriate safety and health practices and determine the applicability of regulatory limitations prior to use.*

2. Referenced Documents

2.1 *ASTM Standards:*²

C670 Practice for Preparing Precision and Bias Statements for Test Methods for Construction Materials

D140 Practice for Sampling Bituminous Materials

D244 Test Methods and Practices for Emulsified Asphalts

D977 Specification for Emulsified Asphalt

D2397 Specification for Cationic Emulsified Asphalt

E1 Specification for ASTM Liquid-in-Glass Thermometers

E11 Specification for Woven Wire Test Sieve Cloth and Test Sieves

3. Terminology

3.1 *Definition:*

3.1.1 *viscosity, n*—ratio of shear stress to shear rate.

¹ This test method is under the jurisdiction of ASTM Committee D04 on Road and Paving Materials and is the direct responsibility of Subcommittee D04.42 on Emulsified Asphalt Test.

Current edition approved Jan. 1, 2006. Published January 2006. DOI: 10.1520/D7226-06E01.

² For referenced ASTM standards, visit the ASTM website, www.astm.org, or contact ASTM Customer Service at service@astm.org. For *Annual Book of ASTM Standards* volume information, refer to the standard's Document Summary page on the ASTM website.

3.1.1.1 *Discussion*—The SI unit of viscosity is the Pascal second (Pa·s). The centimetre gram second (cgs) unit of viscosity is the poise (dynes/cm²) and is equivalent to 0.1 Pa·s. One centipoise (cP) is one millipascal second (mPa·s).

4. Summary of Test Method

4.1 The paddle rotational viscometer for this test method is used to measure the apparent viscosity of emulsified asphalt at 50°C (122°F) between 30 and 1500 mPa·s (cP). A microprocessor circuitry system functioning in tandem with a temperature probe and equipped with internal electronic sensors detects and analyzes the preset temperature. A paddle is immersed in the emulsified asphalt sample and is rotated at 100 RPM.³ The apparent viscosity of the sample is obtained within 5 min and read from the electronic display or optional printer.

5. Significance and Use

5.1 This test method is useful to measure the apparent viscosity of emulsified asphalt at a temperature of 50°C (122°F) or another agreed-upon temperature.⁴ The preset temperature and rotational speed at 100 RPM allow for an automated determination of an emulsified asphalt apparent viscosity within 5 min.

6. Apparatus

6.1 The paddle viscometer test system consists of a paddle, temperature probe, sample cup, the sample cup cover, a means for controlling the sample temperature to 50 ± 0.1°C (122 ± 0.18°F), and readout system to display viscosity. The dimensions of the sample cup and paddle are shown in Figs. 1-3.

6.2 *Thermometer*—ASTM No. 19F or 19C for tests at 50°C conforming to the requirements of Specification E1.

³ Emulsions are sensitive to RPM, therefore, the manufacturer has preset the instrument to run at 100 RPM.

⁴ No accurate predictable conversion from mPa seconds to Saybolt Furool Seconds (SFS) is available at this time. However, an empirical correlation between SFS and mPa seconds can be obtained by performing the respective viscosity measurements on the appropriate equipment.

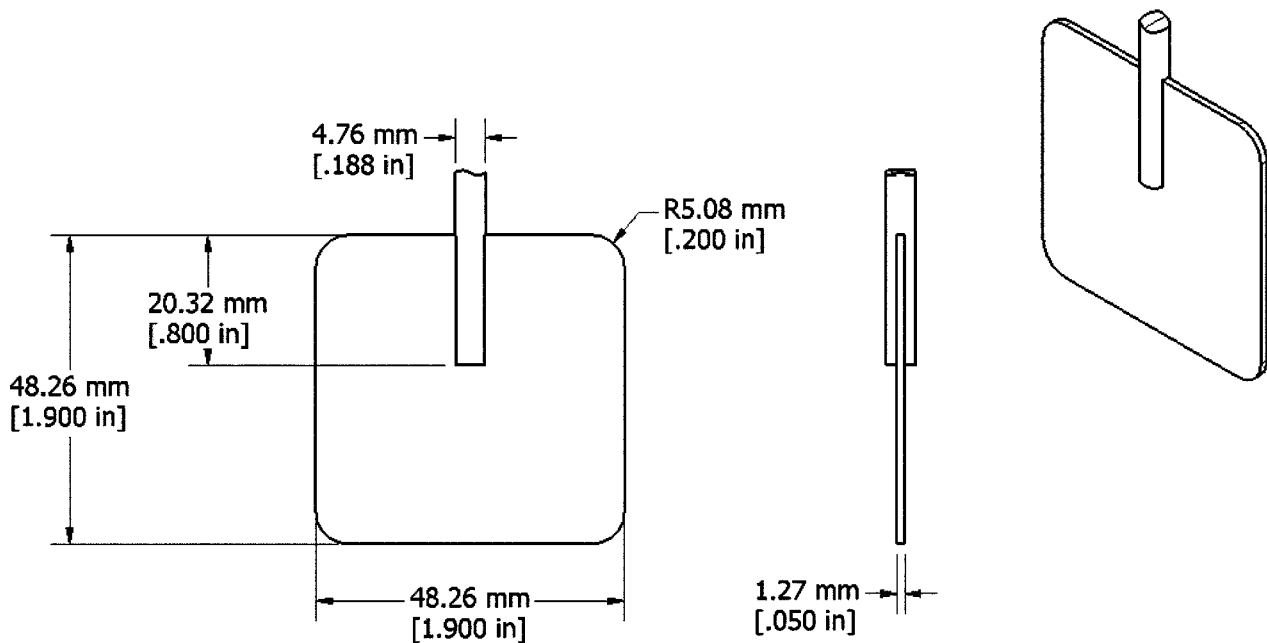

Tolerance $\pm .127\text{mm}$
 $\pm [.005 \text{ in}]$

FIG. 1 Paddle Dimensions, mm (in.)

Liquid Height

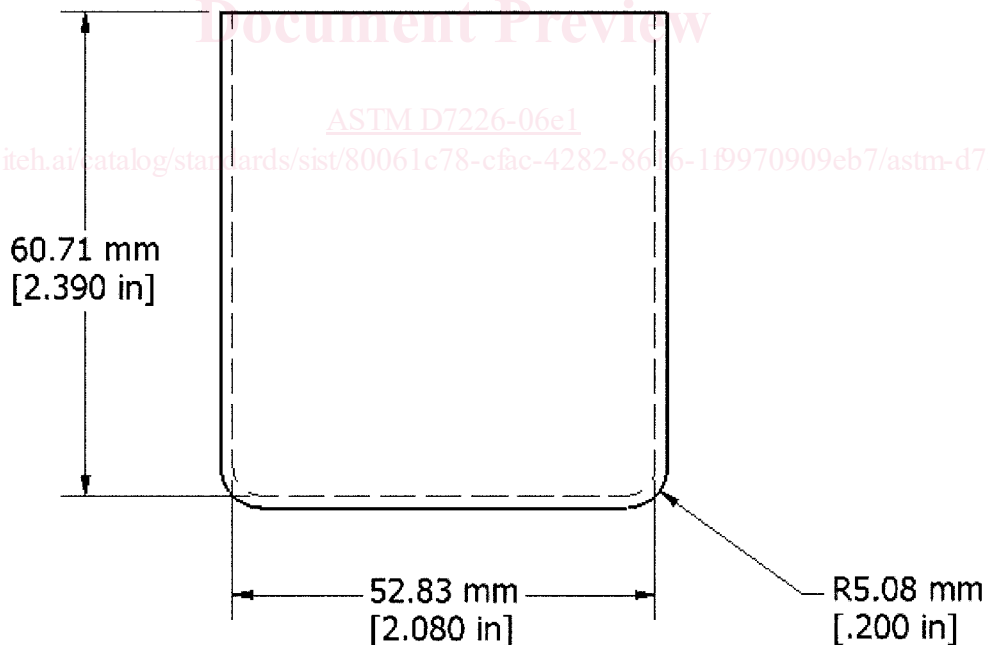

Tolerance $\pm .127\text{mm}$
 $\pm [.005 \text{ in}]$

FIG. 2 Sample Cup Dimensions, mm (in.)