**Diesel engines — 60° female cones
for high-pressure fuel injection
components**

*Moteurs diesels — Raccords finaux à cône femelle de 60° pour lignes
d'injection de combustible haute pression*

iTeh STANDARD PREVIEW
(standards.iteh.ai)

[ISO 2974:2018](https://standards.iteh.ai/catalog/standards/sist/b4850bf8-e03d-4b88-9c67-d55155a4154e/iso-2974-2018)

[https://standards.iteh.ai/catalog/standards/sist/b4850bf8-e03d-4b88-9c67-
d55155a4154e/iso-2974-2018](https://standards.iteh.ai/catalog/standards/sist/b4850bf8-e03d-4b88-9c67-d55155a4154e/iso-2974-2018)



iTeh STANDARD PREVIEW
(standards.iteh.ai)

ISO 2974:2018

<https://standards.iteh.ai/catalog/standards/sist/b4850bf8-e03d-4b88-9c67-d55155a4154e/iso-2974-2018>



COPYRIGHT PROTECTED DOCUMENT

© ISO 2018

All rights reserved. Unless otherwise specified, or required in the context of its implementation, no part of this publication may be reproduced or utilized otherwise in any form or by any means, electronic or mechanical, including photocopying, or posting on the internet or an intranet, without prior written permission. Permission can be requested from either ISO at the address below or ISO's member body in the country of the requester.

ISO copyright office
CP 401 • Ch. de Blandonnet 8
CH-1214 Vernier, Geneva
Phone: +41 22 749 01 11
Fax: +41 22 749 09 47
Email: copyright@iso.org
Website: www.iso.org

Published in Switzerland

Contents		Page
Foreword		iv
1	Scope	1
2	Normative references	1
3	Terms and definitions	1
4	Requirements	2
	4.1 Dimensions and tolerances.....	2
	4.2 Materials.....	2
5	Designation	2
6	Figures and tables	3
	6.1 Integral 60° female cone.....	3
	6.2 Fabricated 60° female cone.....	7
Bibliography		10

iTeh STANDARD PREVIEW
(standards.iteh.ai)

[ISO 2974:2018](https://standards.iteh.ai/catalog/standards/sist/b4850bf8-e03d-4b88-9c67-d55155a4154e/iso-2974-2018)

<https://standards.iteh.ai/catalog/standards/sist/b4850bf8-e03d-4b88-9c67-d55155a4154e/iso-2974-2018>

Foreword

ISO (the International Organization for Standardization) is a worldwide federation of national standards bodies (ISO member bodies). The work of preparing International Standards is normally carried out through ISO technical committees. Each member body interested in a subject for which a technical committee has been established has the right to be represented on that committee. International organizations, governmental and non-governmental, in liaison with ISO, also take part in the work. ISO collaborates closely with the International Electrotechnical Commission (IEC) on all matters of electrotechnical standardization.

The procedures used to develop this document and those intended for its further maintenance are described in the ISO/IEC Directives, Part 1. In particular the different approval criteria needed for the different types of ISO documents should be noted. This document was drafted in accordance with the editorial rules of the ISO/IEC Directives, Part 2 (see www.iso.org/directives).

Attention is drawn to the possibility that some of the elements of this document may be the subject of patent rights. ISO shall not be held responsible for identifying any or all such patent rights. Details of any patent rights identified during the development of the document will be in the Introduction and/or on the ISO list of patent declarations received (see www.iso.org/patents).

Any trade name used in this document is information given for the convenience of users and does not constitute an endorsement.

For an explanation on the voluntary nature of standards, the meaning of ISO specific terms and expressions related to conformity assessment, as well as information about ISO's adherence to the World Trade Organization (WTO) principles in the Technical Barriers to Trade (TBT) see the following URL: www.iso.org/iso/foreword.html. (standards.iteh.ai)

This document was prepared by Technical Committee ISO/TC 22, *Road vehicles*, Subcommittee SC 34, *Propulsion, powertrain, and powertrain fluids*. ISO 2974:2018
<https://standards.iteh.ai/catalog/standards/sist/b4850bf8-e03d-4b88-9c67-5551ghel54639102>

This ninth edition cancels and replaces the eighth edition (ISO 2974:2016), of which it constitutes a minor revision. The changes compared to the previous edition are as follows:

- the surface roughness designation in [Figures 1](#) and [5](#) has been corrected to reflect Best Practices;
- minor typing errors within [Figures 1](#) and [5](#) have been corrected.

Diesel engines — 60° female cones for high-pressure fuel injection components

1 Scope

This document specifies the dimensional requirements of end-connections for high-pressure fuel injection equipment components, used on diesel (compression-ignition) engines.

It is applicable to externally threaded 60° female cones (see [Figures 1, 2, 5, and 6](#)) and intended for use with high-pressure fuel injection pipe assemblies with tube outside diameters of:

- up to and including 12 mm for integral female cones (see [Table 1](#)); and
- up to and including 9 mm for fabricated female cones (see [Table 2](#)).

Details of the pipe connection ends referenced in this document are shown in ISO 13296.

2 Normative references

The following documents are referred to in the text in such a way that some or all of their content constitutes requirements of this document. For dated references, only the edition cited applies. For undated references, the latest edition of the referenced document (including any amendments) applies.

ISO 261, *ISO general purpose metric screw threads — General plan*

ISO 1302, *Geometrical Product Specifications (GPS) — Indication of surface texture in technical product documentation*

ISO 3508, *Thread run-outs for fasteners with thread in accordance with ISO 261 and ISO 262*

ISO 13296, *Diesel engines — High-pressure fuel injection pipe assemblies — General requirements and dimensions*

3 Terms and definitions

For the purposes of this document, the following terms and definitions apply.

ISO and IEC maintain terminological databases for use in standardization at the following addresses:

- ISO Online browsing platform: available at <https://www.iso.org/obp>
- IEC Electropedia: available at <http://www.electropedia.org/>

3.1

integral female cone

female cone where the sealing cone and the thread are connected in the same part

Note 1 to entry: See [Figures 1](#) and [2](#).

3.2

fabricated female cone

female cone where the sealing cone and the thread are separate parts prior to joining, e.g. by welding

Note 1 to entry: See [Figures 5](#) and [6](#).

3.3 reference diameter

S

baseline for dimensioning of the female cone and the pipe end form

Note 1 to entry: *S* can be coincident with the intended nominal sealing interface between the female cone and the pipe end form, or not.

4 Requirements

4.1 Dimensions and tolerances

The following figures indicate the requirements for the 60° female cones at fuel injectors, CR-injectors, fuel injection pumps, high-pressure supply pumps, and rails to allow interchangeability for high-pressure fuel injection pipe assemblies according to ISO 13296:

- [Figures 1, 2, 3, and 4](#) for integral female cones;
- [Figures 5, 6, and 7](#) for fabricated female cones.

The 60° female cone and its relationship to the external thread shall meet the requirements of [Figure 1](#) (integral female cones) or [Figure 5](#) (fabricated female cones). However, for integral female cones, variations at the smaller end of the female cone as shown in [Figure 3](#) are acceptable.

Dimensions and tolerances are given in [Table 1](#) (integral female cones) and [Table 2](#) (fabricated female cones). Unspecified details are left to the manufacturer's choice.

With reference dimension *T* in [Figures 1, 2, 5, and 6](#), the external thread may be either with or without undercut. However, it shall be possible to screw the GO-gauge for the thread up to the plane specified by dimension *T*.

[Figure 4](#) and [Figure 7](#) show the assemblies with pipe end connections for the integral and fabricated female cone types, respectively.

4.2 Materials

The specification of material and heat treatment shall be made according to the intended use. To ensure tightness of the joint between the connection end of the high-pressure pipe and the female cone of the mating part of pump, injector, or rail for the initial assembly as well as for repeated assemblies, the necessary plastic deformation shall take place at the sealing face of the high-pressure pipe.

For this purpose, the minimum hardness of the female cone should be a minimum of 50 HV harder than the maximum hardness of the pipe connection end. However, it shall be proven that the pipe sealing cone with its plastic deformation caused by assembly, in combination with the minimum preload, ensures the tightness of the joint for the initial and repeated assembly processes over the product's useful life.

5 Designation

A 60° female cone conforming to this document shall be designated by the following elements, in the order given:

- a) the term of the 60° female cone, in accordance with [3.1](#) or [3.2](#);
- b) a reference to this document (i.e. ISO 2974);
- c) the shape, in accordance with [Figure 3](#) (for integral female cones only);
- d) the tube outside diameter, in millimetres;

e) the thread designation, in accordance with ISO 261.

EXAMPLE 1

A 60° female cone in accordance with 3.1 (integral female cone) of shape A, of pipe outside diameter 10 mm, and with an external thread M22 × 1,5 is designated:

Integral female cone ISO 2974 A 10 – M22 × 1,5

EXAMPLE 2

A 60° female cone in accordance with 3.2 (fabricated female cone), of pipe outside diameter 6,35 mm, and with an external thread M14 × 1,5 is designated:

Fabricated female cone ISO 2974 6,35 – M14 × 1,5

6 Figures and tables

6.1 Integral 60° female cone

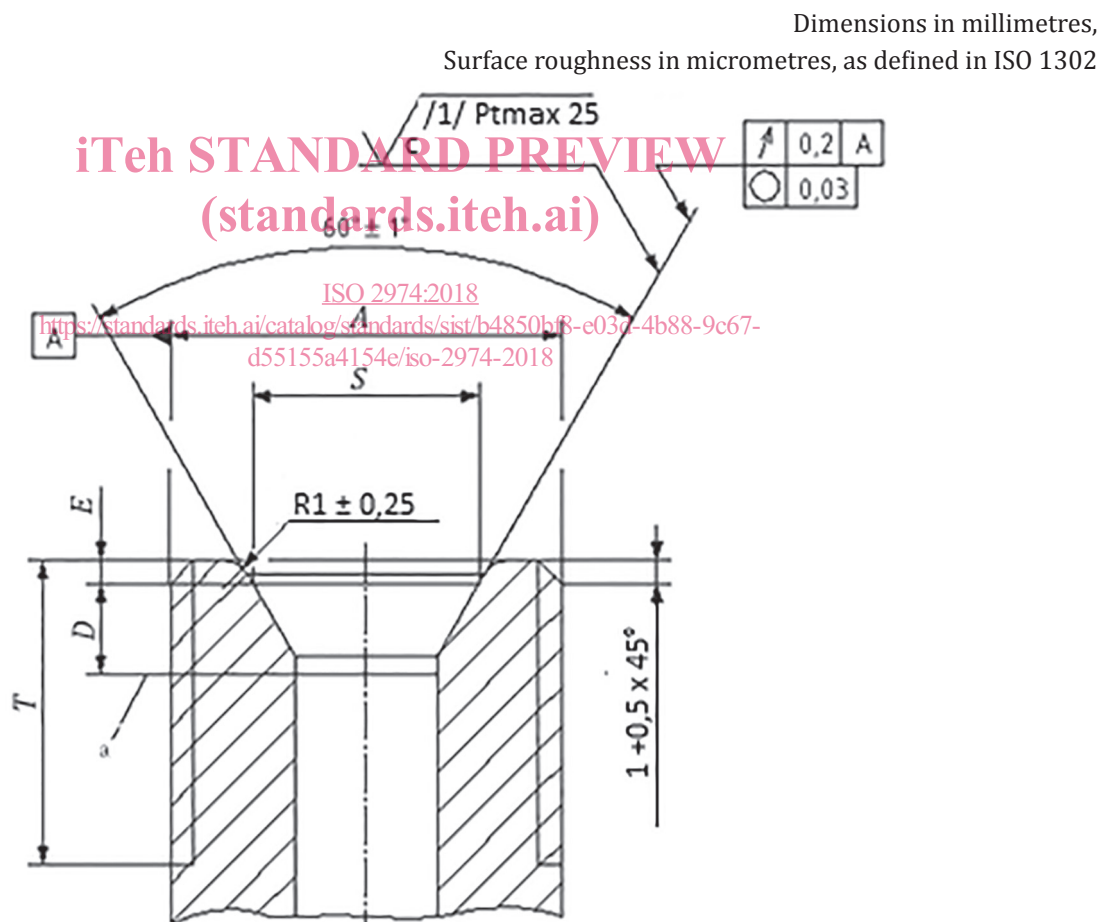

a Highest point of any inserted device. Care shall be taken to ensure that the pipe end does not touch any inserted device after final assembly.

NOTE See Table 1 for dimensions A, E, D, S, and T.

Figure 1 — Integral 60° female cone without undercut

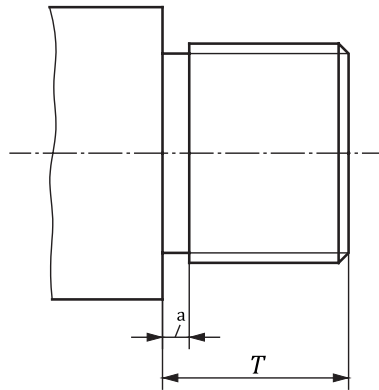

a Undercut in accordance with ISO 3508.

NOTE 1 All dimensions and specifications other than the undercut, a , are the same as for the female cone of [Figure 1](#).

NOTE 2 See [Table 1](#) for dimension T .

Figure 2 — Integral 60° female cone with undercut

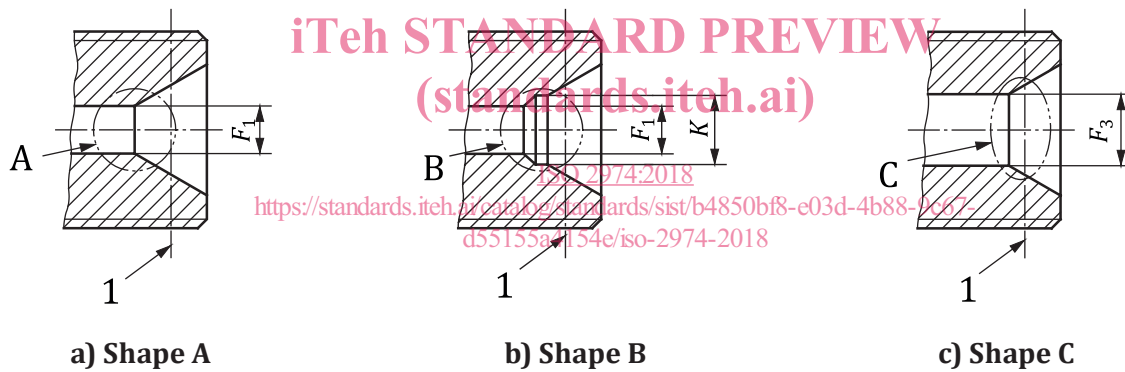

Key

- 1 reference diameter plane (see dimension S in [Table 1](#))
- K (counterbore), size to be agreed between supplier and customer

NOTE See [Table 1](#) for dimensions F_1 and F_3 . Shape C is used for any inserted device (i.e. throttle or edge filter).

Figure 3 — Shapes on integral 60° female cones according to [Figures 1](#) and [2](#)

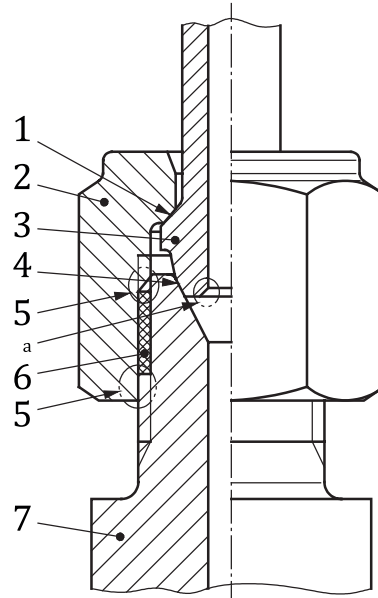
**Key**

- 1 contact area of connector nut (2) and pipe connection end (3)
- 2 connector nut
- 3 connection end of pipe (end form); see NOTE
- 4 contact area (sealing area) of pipe connection end (3) and female cone connector (7)
- 5 chamfer to root of thread [connector nut (2) and connector (7)]
- 6 engaged thread (recommended design should allow 3x pitch minimum)
- 7 female cone (connector)
- a Pipe connection end [pipe connection end bore entrance configuration shall be chosen such that after final assembly, the pipe inside diameter is not reduced (see ISO 13296)].

NOTE For details of pipe connection ends, see ISO 13296.

Figure 4 — Pipe end assembly for integral 60° female cone (basic relationships)