

ISO/TC 83/SC 4

Secretariat: ASI

Voting begins on:
2021-03-01

Voting terminates on:
2021-04-26

Alpine ski boots with improved walking soles — Interface with alpine ski-bindings – Requirements and test methods

Chaussures de ski pour skis alpins dotées de semelles de marche améliorées — Zone de contact avec les fixations de ski alpin — Exigences et méthodes d'essai

iTeh STANDARD PREVIEW
(standards.iteh.ai)

ISO/FDIS 23223

<https://standards.iteh.ai/catalog/standards/sist/fd14b57d-a658-4e84-9747-be436d683c1c/iso-fdis-23223>

RECIPIENTS OF THIS DRAFT ARE INVITED TO SUBMIT, WITH THEIR COMMENTS, NOTIFICATION OF ANY RELEVANT PATENT RIGHTS OF WHICH THEY ARE AWARE AND TO PROVIDE SUPPORTING DOCUMENTATION.

IN ADDITION TO THEIR EVALUATION AS BEING ACCEPTABLE FOR INDUSTRIAL, TECHNOLOGICAL, COMMERCIAL AND USER PURPOSES, DRAFT INTERNATIONAL STANDARDS MAY ON OCCASION HAVE TO BE CONSIDERED IN THE LIGHT OF THEIR POTENTIAL TO BECOME STANDARDS TO WHICH REFERENCE MAY BE MADE IN NATIONAL REGULATIONS.



Reference number
ISO/FDIS 23223:2021(E)

iTeh STANDARD PREVIEW (standards.iteh.ai)

[ISO/FDIS 23223](https://standards.iteh.ai/catalog/standards/sist/fd14b57d-a658-4e84-9747-be436d683c1c/iso-fdis-23223)

<https://standards.iteh.ai/catalog/standards/sist/fd14b57d-a658-4e84-9747-be436d683c1c/iso-fdis-23223>



COPYRIGHT PROTECTED DOCUMENT

© ISO 2021

All rights reserved. Unless otherwise specified, or required in the context of its implementation, no part of this publication may be reproduced or utilized otherwise in any form or by any means, electronic or mechanical, including photocopying, or posting on the internet or an intranet, without prior written permission. Permission can be requested from either ISO at the address below or ISO's member body in the country of the requester.

ISO copyright office
CP 401 • Ch. de Blandonnet 8
CH-1214 Vernier, Geneva
Phone: +41 22 749 01 11
Email: copyright@iso.org
Website: www.iso.org

Published in Switzerland

Contents

	Page
Introduction	iv
Foreword	v
1 Scope	1
2 Normative references	1
3 Terms and definitions	1
4 Requirements and test methods	2
4.1 General.....	2
4.2 Dimensions and evenness.....	2
4.2.1 Dimensions.....	2
4.2.2 Evenness.....	7
4.3 Design.....	9
4.3.1 Sole length.....	9
4.3.2 Symmetry.....	9
4.3.3 Side walls.....	9
4.3.4 Free spaces.....	13
4.3.5 Bearing surfaces.....	20
4.3.6 Interfaces.....	26
4.3.7 Style of boot shell.....	30
4.3.8 Mounting point.....	31
4.3.9 Sole length.....	31
5 Marking	31
6 Information supplied by the manufacturer	31
6.1 General.....	31
6.2 User manual.....	32
Annex A (informative) Mondopoint system ski-boot sizing and marking	33
Annex B (informative) Dimensions and requirements of “2nd degree”	34
Annex C (informative) Test body for dimensional test of free space to binding	36
Annex D (normative) Test gauge for dimensional check	39
Bibliography	41

Introduction

The International Organization for Standardization (ISO) draws attention to the fact that it is claimed that compliance with this document may involve the use of a patent.

ISO take no position concerning the evidence, validity and scope of this patent right.

The holder of this patent right has assured ISO that he/she is willing to negotiate licences under reasonable and non-discriminatory terms and conditions with applicants throughout the world. In this respect, the statement of the holder of this patent right is registered with ISO. Information may be obtained from the patent database available at www.iso.org/patents.

Attention is drawn to the possibility that some of the elements of this document may be the subject of patent rights other than those in the patent database. ISO shall not be held responsible for identifying any or all such patent rights.

iTeh STANDARD PREVIEW (standards.iteh.ai)

ISO/FDIS 23223

<https://standards.iteh.ai/catalog/standards/sist/fd14b57d-a658-4e84-9747-be436d683c1c/iso-fdis-23223>

Foreword

ISO (the International Organization for Standardization) is a worldwide federation of national standards bodies (ISO member bodies). The work of preparing International Standards is normally carried out through ISO technical committees. Each member body interested in a subject for which a technical committee has been established has the right to be represented on that committee. International organizations, governmental and non-governmental, in liaison with ISO, also take part in the work. ISO collaborates closely with the International Electrotechnical Commission (IEC) on all matters of electrotechnical standardization.

The procedures used to develop this document and those intended for its further maintenance are described in the ISO/IEC Directives, Part 1. In particular, the different approval criteria needed for the different types of ISO documents should be noted. This document was drafted in accordance with the editorial rules of the ISO/IEC Directives, Part 2 (see www.iso.org/directives).

Attention is drawn to the possibility that some of the elements of this document may be the subject of patent rights. ISO shall not be held responsible for identifying any or all such patent rights. Details of any patent rights identified during the development of the document will be in the Introduction and/or on the ISO list of patent declarations received (see www.iso.org/patents).

Any trade name used in this document is information given for the convenience of users and does not constitute an endorsement.

For an explanation of the voluntary nature of standards, the meaning of ISO specific terms and expressions related to conformity assessment, as well as information about ISO's adherence to the World Trade Organization (WTO) principles in the Technical Barriers to Trade (TBT), see www.iso.org/iso/foreword.html.

This document was prepared by Technical Committee ISO/TC 83, *Sports and other recreational facilities and equipment*, Subcommittee SC 4, *Snowsports equipment*.

Any feedback or questions on this document should be directed to the user's national standards body. A complete listing of these bodies can be found at www.iso.org/members.html.

iTeh STANDARD PREVIEW
(standards.iteh.ai)

ISO/FDIS 23223

<https://standards.iteh.ai/catalog/standards/sist/fd14b57d-a658-4e84-9747-be436d683c1c/iso-fdis-23223>

Alpine ski boots with improved walking soles — Interface with alpine ski-bindings – Requirements and test methods

1 Scope

This document specifies requirements, test methods and marking for alpine ski-boots with improved walking soles that are used with systems of alpine ski-bindings for improved walking soles with attachment at the boot front and boot rear, the proper release function of which depends on the dimensions and design of the interfaces.

Alpine ski boots with improved walking soles are intended to a better walkability without affecting the function of the alpine ski binding designed for improved walking soles.

This document is applicable to ski-boots of sizes 15,0 and larger (Types A (Adults) and C (Children)) in the Mondo point system (see [Annex A](#)).

2 Normative references

The following documents are referred to in the text in such a way that some or all of their content constitutes requirements of this document. For dated references, only the edition cited applies. For undated references, the latest edition of the referenced document (including any amendments) applies.

ISO 527-1, *Plastics — Determination of tensile properties — Part 1: General principles*

ISO 527-2, *Plastics — Determination of tensile properties — Part 2: Test conditions for moulding and extrusion plastics* <https://standards.iteh.ai/catalog/standards/sist/fd14b57d-a658-4e84-9747-be436d683c1c/iso-fdis-23223>

ISO 554, *Standard atmospheres for conditioning and/or testing — Specifications*

ISO 868, *Plastics and ebonite — Determination of indentation hardness by means of a durometer (Shore hardness)*

ISO 1183 (all parts), *Plastics — Methods for determining the density and relative density of non-cellular plastics*

ISO 2039-1, *Plastics — Determination of hardness — Part 1: Ball indentation method*

ISO 11088, *Alpine ski/binding/boot (S-B-B) system — Assembly, adjustment and inspection*

ISO 13993, *Rental ski shop practice — Sampling and inspection of complete and incomplete alpine ski-binding-boot systems in rental applications*

3 Terms and definitions

For the purposes of this document, the following terms and definitions apply.

ISO and IEC maintain terminological databases for use in standardization at the following addresses:

— ISO Online browsing platform: available at <https://www.iso.org/obp>

— IEC Electropedia: available at <http://www.electropedia.org/>

3.1

interface

part of the ski-boot intended to be in contact with the ski-binding

3.2

front interface

part of the ski-boot intended to be in contact with the front binding

3.3

rear interface

part of the ski-boot intended to be in contact with the rear binding

3.4

free space

space intended to avoid contact between ski-boot and binding, especially during step in/step out or release

3.5

bearing surfaces

front and rear surfaces of the boot sole that are in contact with the ski binding

3.6

median plane

middle plane of the sole, longitudinal and perpendicular to the bearing surface

3.7

ski-brake

device to stop the ski after release of the binding

3.8

walking sole

sole with hard and soft materials and an optimized profile, intended to a better walkability without affecting the function of the alpine ski binding

3.9

low-friction zone

area of the bearing surfaces that have a low-friction coefficient

iTeh STANDARD PREVIEW
(standards.iteh.ai)

ISO/FDIS 23223

https://standards.iteh.ai/catalog/standards/sist/14b57d-a658-4e84-9747-be436d683c1c/iso-fdis-23223

4 Requirements and test methods

4.1 General

If no specific test method is indicated, check the characteristics as appropriate, e.g. by measurement.

If not otherwise indicated, execute the testing under standard atmosphere 23/50 in accordance with ISO 554 with ordinary tolerances.

A test body for dimensional test of free space to binding is defined in [Annex C](#).

4.2 Dimensions and evenness

4.2.1 Dimensions

The boot toe and heel shall conform with [Figure 1](#), [Figure 2](#), [Figure 3](#), [Figure 4](#) and [Figure 5](#).

All dimensions shall be within the indicated tolerances. However, relevance to safety varies in importance depending on the indicated dimensions.

Measurements in gauge shall be done with a preload of 100 N and 50 N for Type A and Type C respectively, by inserting into the ski-boot itself a steel cylinder.

Looking at several dimensions (for dimensions of the 2nd degree, see [Annex B](#)) a deviation from the tolerances may be accepted, provided that the following requirements are respected:

- a) The deviations shall remain exceptional.

- b) The deviations shall be small.
- c) No limitations of function shall arise with all marketable and critical bindings.
- d) The tolerances shall be respected at the next possible chance (e.g. reconstruction of a tool).

Dimensions for boots with inserts working with pin bindings are given in this document.

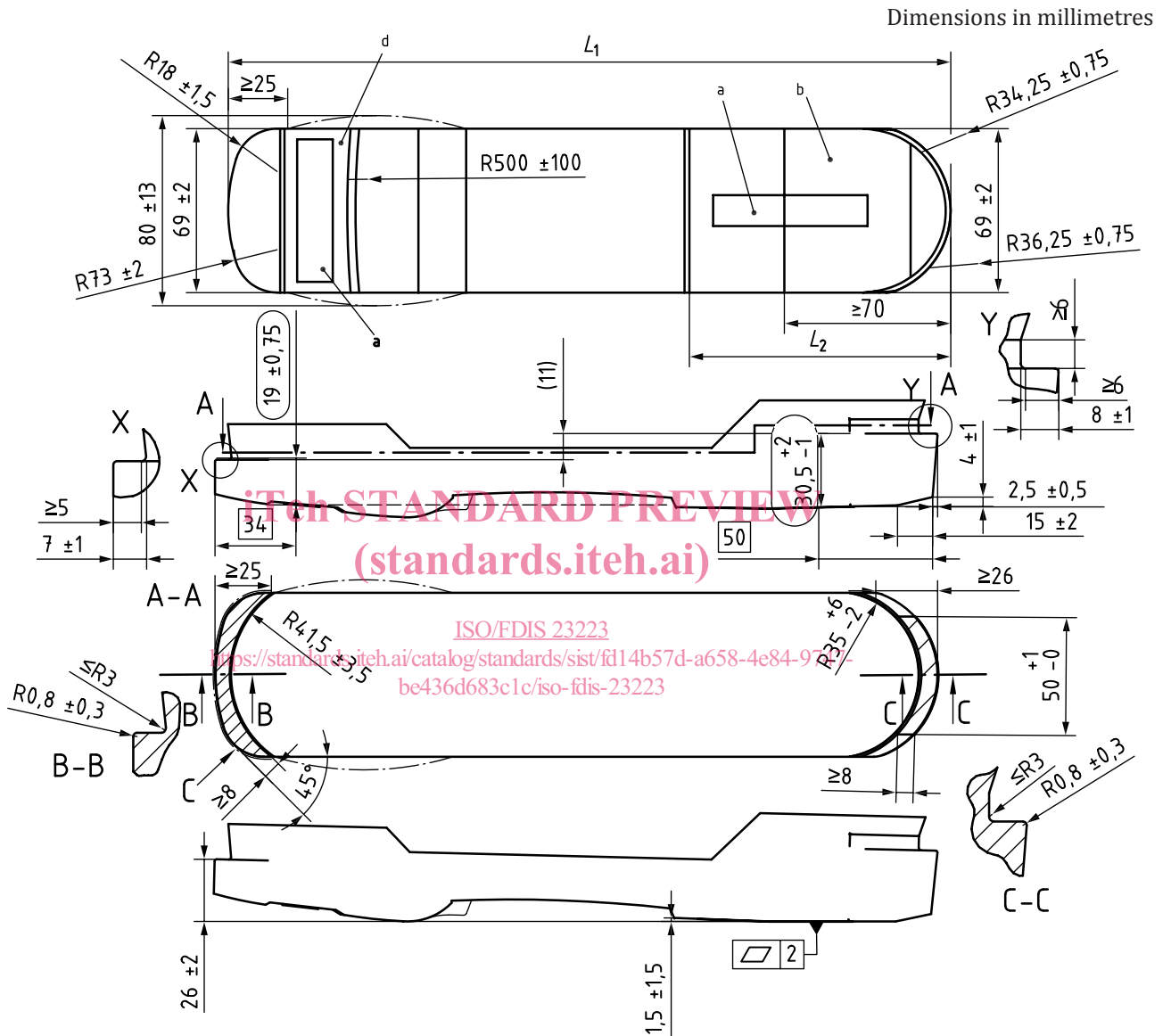

L_1 sole length

L_2 heel length

a Low-friction zone in accordance with 4.3.5.1.

b Bearing surface.

c Area in which the tolerance of perpendicularity is valid (see 4.3.3.1).

d Section of recessed soft component not in contact with the binding.

L_1	<300	≥ 300
L_2	≥ 100	≥ 110

NOTE Shaded areas including areas with index c are those in which the tolerances of evenness and the dimensions $19 \pm 0,75$ and $30,5 +2/-1$ are valid.

Figure 1 — Dimensions of boot toe and heel, Type A

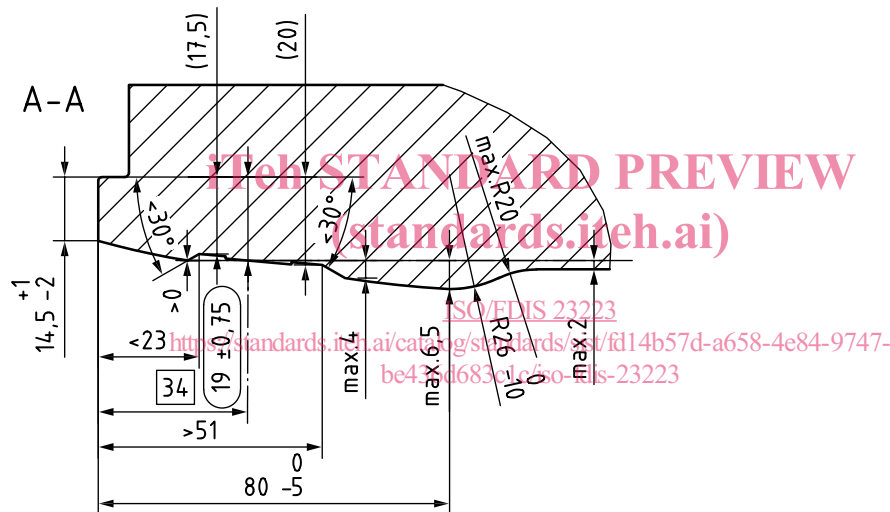
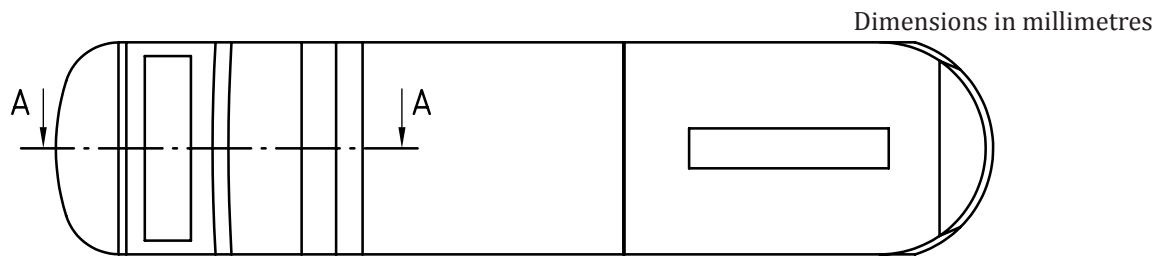

NOTE Some of these measurements are of 2nd degree, see Annex B.

Figure 2 — Detailed dimensions of boot, Type A

Figure 2 provides all the key dimensions (nominal) to build new boots. The gauge (see Annex C) can be used to check whether a boot is in conformity with this document.

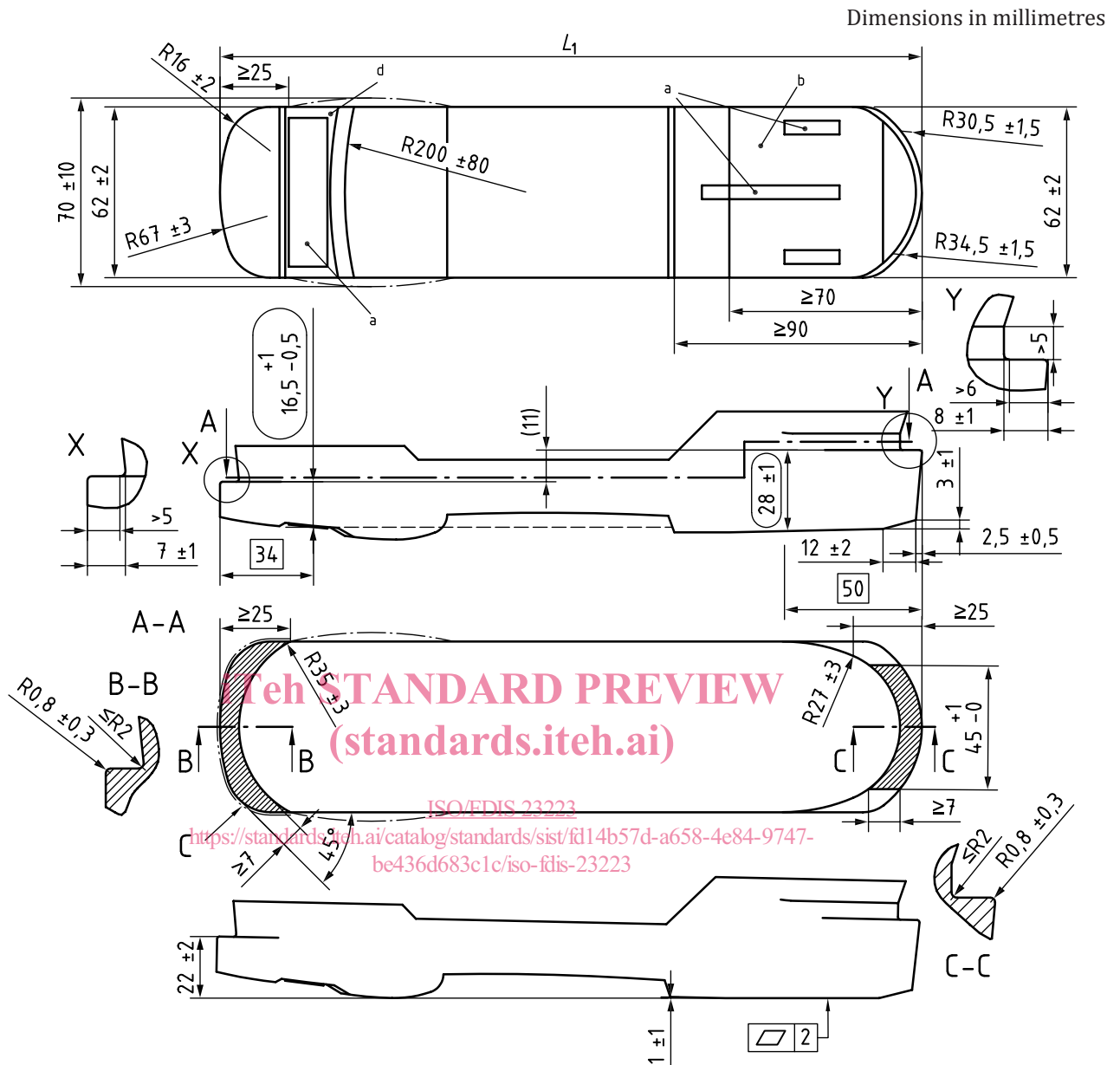

Key

- a Low-friction zone in accordance with 4.3.5.1.
 - b Bearing surface.
 - c Area in which the tolerance of perpendicularity is valid (see 4.3.3.1).
 - d Section of recessed soft component not in contact to binding.
- L_1 sole length

NOTE Shaded areas, including areas designated by footnote c, are those in which the tolerances of evenness and the dimensions $16,5^{+1}_{-0,5}$ and 28 ± 1 are valid.

Figure 3 — Dimensions of boot toe and heel, Type C

Dimensions in millimetres

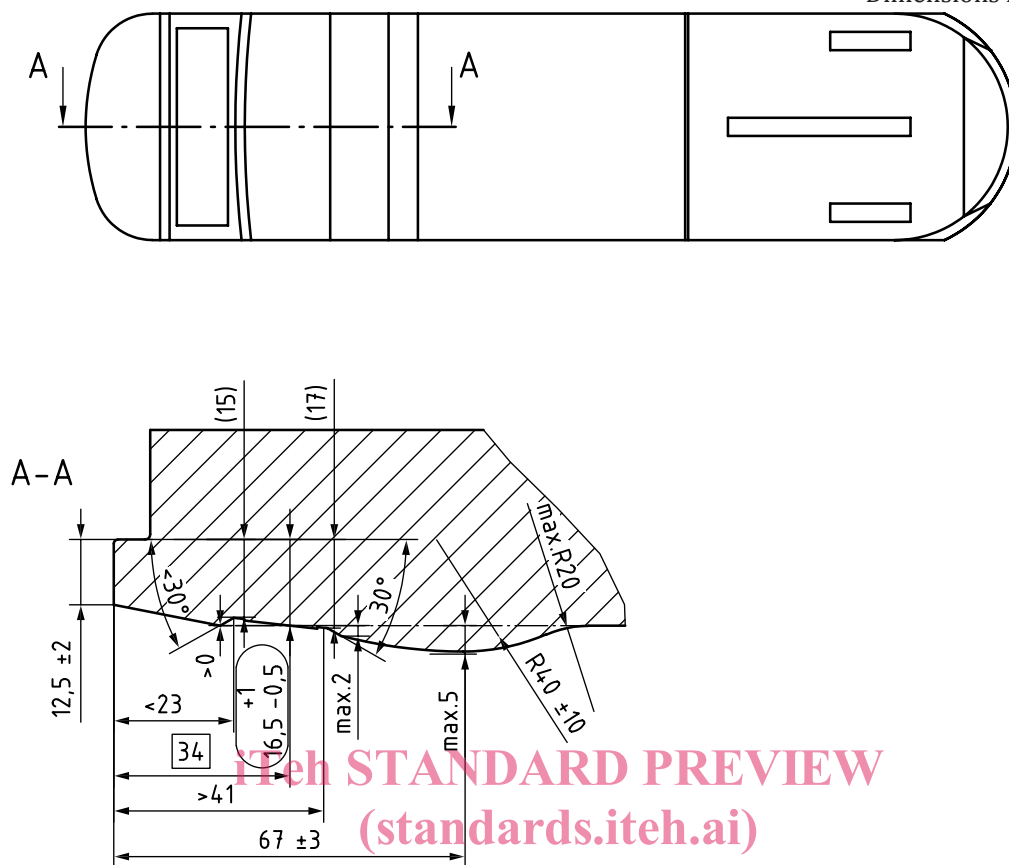

NOTE Some of these measurements are of 2nd degree, see Annex B.
<https://standards.iteh.ai/catalog/standards/sist/fd14b57d-a658-4e84-9747-be436d683c1c/iso-fdis-23223>

Figure 4 — Detailed dimensions of boot, Type C

Figure 4 provides all the key dimensions (nominal) to build new boots. The gauge (see Annex C) can be used to check whether a boot is in conformity with this document.

