**Personal protective equipment —
Footwear — Test method for slip
resistance**

*Équipement de protection individuelle — Chaussures — Méthode
d'essai pour la résistance au glissement*

iTeh Standards
(<https://standards.iteh.ai>)
Document Preview

[ISO 13287:2019](https://standards.iteh.ai/catalog/standards/iso/a59feb9f-ab82-45c7-ab57-3baa4fcb013a/iso-13287-2019)

<https://standards.iteh.ai/catalog/standards/iso/a59feb9f-ab82-45c7-ab57-3baa4fcb013a/iso-13287-2019>



iTeh Standards
(<https://standards.iteh.ai>)
Document Preview

[ISO 13287:2019](https://standards.iteh.ai/catalog/standards/iso/a59feb9f-ab82-45c7-ab57-3baa4fcb013a/iso-13287-2019)

<https://standards.iteh.ai/catalog/standards/iso/a59feb9f-ab82-45c7-ab57-3baa4fcb013a/iso-13287-2019>



COPYRIGHT PROTECTED DOCUMENT

© ISO 2019

All rights reserved. Unless otherwise specified, or required in the context of its implementation, no part of this publication may be reproduced or utilized otherwise in any form or by any means, electronic or mechanical, including photocopying, or posting on the internet or an intranet, without prior written permission. Permission can be requested from either ISO at the address below or ISO's member body in the country of the requester.

ISO copyright office
CP 401 • Ch. de Blandonnet 8
CH-1214 Vernier, Geneva
Phone: +41 22 749 01 11
Fax: +41 22 749 09 47
Email: copyright@iso.org
Website: www.iso.org

Published in Switzerland

Contents

	Page
Foreword	iv
1 Scope	1
2 Normative references	1
3 Terms and definitions	1
4 Apparatus and materials	2
5 Sampling and conditioning	4
5.1 Sampling.....	4
5.2 Conditioning.....	4
6 Test method	4
6.1 Principle.....	4
6.2 Test modes and test conditions.....	5
7 Preparation of footwear and floor	10
7.1 Footwear.....	10
7.2 Floor.....	11
8 Procedure	12
9 Test report	13
Annex A (normative) Standard shoemaking last and mechanical foot for testing footwear	14
Annex B (normative) Specification of Eurotile 2 (OFIR)	16
Annex C (normative) Calibration procedure for Eurotile 2 and other test surfaces	19
Bibliography	23

Document Preview

[ISO 13287:2019](https://standards.iteh.ai/catalog/standards/iso/a59feb9f-ab82-45c7-ab57-3baa4fcb013a/iso-13287-2019)

<https://standards.iteh.ai/catalog/standards/iso/a59feb9f-ab82-45c7-ab57-3baa4fcb013a/iso-13287-2019>

Foreword

ISO (the International Organization for Standardization) is a worldwide federation of national standards bodies (ISO member bodies). The work of preparing International Standards is normally carried out through ISO technical committees. Each member body interested in a subject for which a technical committee has been established has the right to be represented on that committee. International organizations, governmental and non-governmental, in liaison with ISO, also take part in the work. ISO collaborates closely with the International Electrotechnical Commission (IEC) on all matters of electrotechnical standardization.

The procedures used to develop this document and those intended for its further maintenance are described in the ISO/IEC Directives, Part 1. In particular, the different approval criteria needed for the different types of ISO documents should be noted. This document was drafted in accordance with the editorial rules of the ISO/IEC Directives, Part 2 (see www.iso.org/directives).

Attention is drawn to the possibility that some of the elements of this document may be the subject of patent rights. ISO shall not be held responsible for identifying any or all such patent rights. Details of any patent rights identified during the development of the document will be in the Introduction and/or on the ISO list of patent declarations received (see www.iso.org/patents).

Any trade name used in this document is information given for the convenience of users and does not constitute an endorsement.

For an explanation of the voluntary nature of standards, the meaning of ISO specific terms and expressions related to conformity assessment, as well as information about ISO's adherence to the World Trade Organization (WTO) principles in the Technical Barriers to Trade (TBT) see www.iso.org/iso/foreword.html.

This document was prepared by Technical Committee ISO/TC 94, *Personal Safety — Personal protective equipment*, Subcommittee SC 3, *Foot protection*.

This third edition cancels and replaces the second edition (ISO 13287:2012), which has been technically revised. The main changes compared to the previous edition are as follows:

- Scope — additional text added;
- [4.10](#), design and use of rigid wedges is more precisely defined, and illustrated in [Figures 1, 2](#) and [C.1](#);
- [5.1](#), requires a left and right sample;
- [5.2](#), conditioning time reduced to 24 h;
- [6.1](#), uncertainty of measurement: additional approaches allowed;
- [Figure 2](#) a)/b) and c) redrawn for clarification;
- New [Figure 5](#) and text in [6.2.2](#) added for curved outsoles;
- [6.2.3](#), UK size changed and requirements for application of force tightened;
- [7.1](#) has been restructured and an additional procedure allowed for cleaning grease contaminated soling;
- [7.2.4](#) to [7.2.6](#) and [8.6](#) concerning floor sample conditioning, cleaning and replacement are revised;
- [Clause 9](#) b) and d) are revised; [Clause 9](#) e) is added;
- [Annex B](#) replaces and updates three previous annexes (Annex B, C and D of ISO 13287:2012) due to the deletion of Eurotile 1; [B.2](#) is a new addition;
- [C.2.1](#) requires S96 to be discarded according to the certificated date.

Any feedback or questions on this document should be directed to the user's national standards body. A complete listing of these bodies can be found at www.iso.org/members.html.

iTeh Standards
(<https://standards.itih.ai>)
Document Preview

[ISO 13287:2019](https://standards.itih.ai/catalog/standards/iso/a59feb9f-ab82-45c7-ab57-3baa4fcb013a/iso-13287-2019)

<https://standards.itih.ai/catalog/standards/iso/a59feb9f-ab82-45c7-ab57-3baa4fcb013a/iso-13287-2019>

Personal protective equipment — Footwear — Test method for slip resistance

1 Scope

This document specifies a method of test for the slip resistance of PPE footwear. It is not applicable to special purpose footwear containing spikes, metal studs or similar.

Footwear claiming 'slip resistance' would be deemed an item of personal protective equipment.

NOTE For product development purposes, sole units, outsoles or other soling components such as top pieces may be tested.

2 Normative references

The following documents are referred to in the text in such a way that some or all of their content constitutes requirements of this document. For dated references, only the edition cited applies. For undated references, the latest edition of the referenced document (including any amendments) applies.

ISO 4287, *Geometrical Product Specifications (GPS) — Surface texture: Profile method — Terms, definitions and surface texture parameters*

ISO 4662, *Rubber, vulcanized or thermoplastic — Determination of rebound resilience*

3 Terms and definitions

For the purposes of this document, the following terms and definitions apply.

ISO and IEC maintain terminological databases for use in standardization at the following addresses:

- ISO Online browsing platform: available at <https://www.iso.org/obp>
- IEC Electropedia: available at <http://www.electropedia.org/>

3.1

normal force

force applied to the surface through the footwear, perpendicular (90°) to the surface

Note 1 to entry: The force includes the weight of the footwear, shoemaking last (4.1.1 or 4.1.2) or mechanical foot (4.1.3) and mounting.

3.2

frictional force

force parallel to the surface and against the direction of movement arising when footwear slides over a surface

3.3

coefficient of friction

CoF

ratio of the frictional force divided by the normal force

3.4

static contact time

time between initial contact of the footwear with the surface achieving a normal force of 50 N and the beginning of movement

**3.5
measurement period**

time interval during which the frictional force measurement is taken and during which the test conditions are satisfied

**3.6
floor**

material (flooring), without contaminant (lubricant), to be used as the test surface

**3.7
surface**

floor, with or without contaminant (lubricant), against which the footwear is tested

**3.8
calibration test value**

CTV
coefficient of friction between the Slider 96¹⁾ and the test surface

4 Apparatus and materials

4.1 One or more of the following foot forms to hold the item of footwear to be tested.

4.1.1 Standard shoemaking last, conforming to [A.1](#).

4.1.2 Manufacturer's shoemaking last used to make the footwear sample to be tested, if required.

4.1.3 Mechanical foot, conforming to the dimensions given in [A.2](#).

4.2 Mechanism for lowering the item of footwear onto the surface and applying the required normal force at the required time in accordance with [Clause 6](#).

4.3 Device for measuring the normal force between the footwear and surface when setting up the test and during the measurement period to an accuracy of 2 % or better.

4.4 Steel floor, consisting of a stainless steel plate.

Surface roughness shall be measured in the area where the slip measurements are actually made. Measurements shall be made at 10 locations within this area and in the direction parallel to the direction of sliding movement in the test. At each location, measurements shall be made with a sampling length of 0,8 mm, taking five sampling lengths per location (evaluation length 4,0 mm).

The average roughness, R_z , shall be measured in accordance with ISO 4287. The overall mean value from all 10 locations shall be for R_z between 1,6 μm and 2,5 μm .

When the roughness parameter does not conform to the above specifications, the steel shall be prepared using silicon carbide abrasive paper or cloth for polishing in a backwards and forwards, linear motion, using a succession of reducing grit sizes. The polishing direction of each operation shall be perpendicular to the preceding operation with the final direction being parallel to the direction of sliding movement in the test. The preparation shall continue until the roughness parameter falls within the above specifications. New steel floor plates shall also be prepared by this method.

NOTE 1 For example, steel Number 1.4301, Type 2G (cold rolled, ground) conforming to EN 10088-2:2005.

1) Slider 96 is the trade name of a product supplied by Smithers Rapra. For contact details please visit <http://isotc.iso.org/livelink/livelink?func=ll&objId=8867539&objAction=browse&sort=name>. This information is given for the convenience of users of this document and does not constitute an endorsement by ISO of the product named. Equivalent products may be used if they can be shown to lead to the same results.

NOTE 2 Grit sizes 100 to 600 can be suitable.

4.5 Pressed ceramic tile floor, as specified in [Annex B](#). The tiles shall not be modified in any way, for example, by mechanical or chemical treatment other than as allowed in [B.2](#).

4.6 Other surfaces, for example, wood, concrete, stone and polymeric flooring, with or without lubricants may be used. The surface used shall be characterized by determining the coefficient of friction in accordance with [Annex C](#).

4.7 Mechanism for inducing movement between the footwear and the surface at a time and speed as specified in [Clause 6](#).

4.8 Device for measuring the frictional force between the footwear and surface during the measurement period to an accuracy of 2 % or better.

4.9 Silicon carbide paper, 400 grit size, mounted on a rigid block with a flat face measuring 100 mm × 70 mm and mass (1 200 ± 120) g.

NOTE This can be achieved using steel to make a block 22 mm thick.

4.10 Rigid wedges having a $(7,0 \pm 0,5)^\circ$ angle for setting the contact angle. The tip of each wedge ([Figure 1](#)) shall be truncated to a maximum height of 0,5 mm as judged by graduated eyepiece or equivalent means. The width of the wedge should be sufficient to ensure that the full width of the heel or forepart shall be fully supported by the wedge. For the heel test, the length shall be sufficient to support the full length of the heel but shall not make contact with the forepart [see [Figure 2 a](#)]. For the forepart test, the length of the wedge shall be sufficient to support the heel and forepart of the shoe [see [Figure 2 b](#)].

The purpose of the wedge when used in [6.2.2](#) and [C.4.3](#) is to ensure that the test footwear or specimen S96 is elevated by no more than ≈ 1 mm above the test surface when the contact angle is being set. To facilitate this, the wedge may be marked with a line parallel to, and ≈ 4 mm from, the truncated edge at the position where the wedge has a height of ≈ 1 mm, as shown in [Figure 1](#).

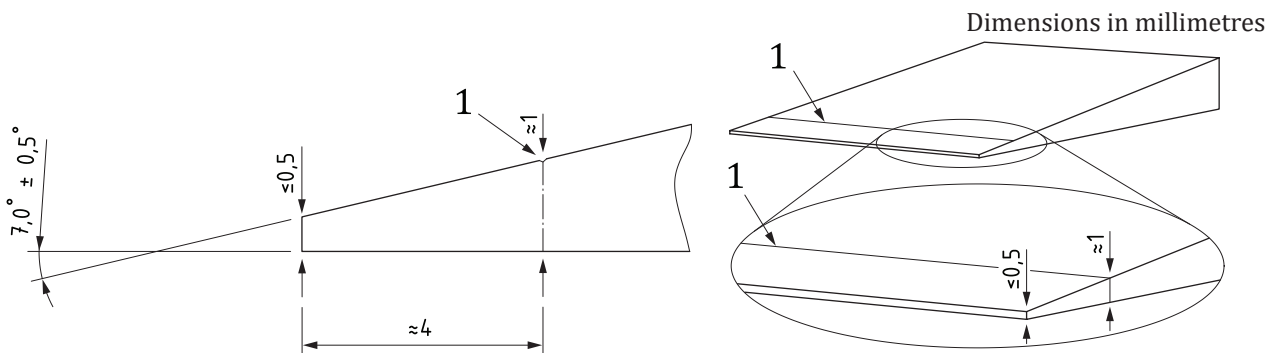

Key

1 marked line

Figure 1 — 7° wedge with line scribed ≈ 4 mm from truncated edge

4.11 Glycerol, aqueous solution with a viscosity of $(0,2 \pm 0,1)$ Pa·s. At 23 °C this corresponds to an aqueous solution containing a mass fraction of approximately 85,6 % to 92,8 % glycerol in demineralized water. For other temperatures, see [Table 1](#) (values for temperatures in the range given in [Table 1](#) may be interpolated). The solution shall be replaced 30 min after exposure to the ambient atmosphere unless it can be shown to still comply with [Table 1](#).

NOTE As a solution containing a mass fraction of approximately 90 % glycerol is hygroscopic in air with a relative humidity of more than 32 %, it is advisable to use solutions with a mass fraction of approximately 90,0 % to 92,5 % glycerol.

Table 1 — Approximate concentrations of glycerol in demineralized water for different temperatures and viscosities

Temperature °C	Concentration and refractive index of glycerol in demineralized water for					
	0,1 Pa·s		0,2 Pa·s		0,3 Pa·s	
	Mass fraction %	Refractive index	Mass fraction %	Refractive index	Mass fraction %	Refractive index
21,0	84,5	1,450 0	89,5	1,457 4	91,9	1,461 0
23,0	85,6	1,450 9	90,4	1,458 4	92,8	1,462 0
25,0	86,6	1,451 2	91,4	1,459 4	93,7	1,462 8

4.12 Detergent solution, containing a mass fraction of 0,5 % sodium lauryl sulfate (SLS) in demineralized water.

4.13 Ethanol solution, containing a mass fraction of (50 ± 5) % ethanol GPR (CAS 64-17-5), which may be prepared from industrial methylated spirits GPR containing minimum 90 % ethanol, in demineralized water.

4.14 Propanone (acetone) (CAS Number 67-64-1), general laboratory grade.

5 Sampling and conditioning

5.1 Sampling

Unless otherwise specified, use a minimum of two samples, one left and one right, of the same type of footwear of the same size.

5.2 Conditioning

The test items shall be conditioned prior to the test at (23 ± 2) °C and (50 ± 5) % RH for a minimum of 24 h. If necessary, the sample may be removed from this standard atmosphere provided that its temperature is maintained at (23 ± 2) °C, that testing starts within 30 min after removal from this standard atmosphere and that the testing is carried out at (23 ± 2) °C.

6 Test method

6.1 Principle

The item of footwear to be tested is put on a surface, subjected to a given normal force, and moved horizontally relative to the surface (or the surface is moved horizontally relative to the item of footwear). Both the frictional force and normal force are measured and the dynamic CoF is calculated.

For each of the required measurements performed in accordance with this document, a corresponding estimate of the uncertainty of measurement should be evaluated. One of the following approaches shall be used:

- a statistical method, e.g. that given in ISO 5725-2[2];
- a mathematical method, e.g. that given in ISO/IEC Guide 98-3[3];

- uncertainty and conformity assessment as given in ISO/IEC Guide 98-4^[4];
- JCGM 100:2008^[5].

6.2 Test modes and test conditions

6.2.1 The footwear shall be tested in one or more of the following modes (see Figure 2):

- a) forward heel slip at angled contact;
- b) backward slip on the forepart;
- c) forward flat slip.

NOTE The heel test mode is considered the most important test mode in relation to reducing the risk of pedestrian slip.

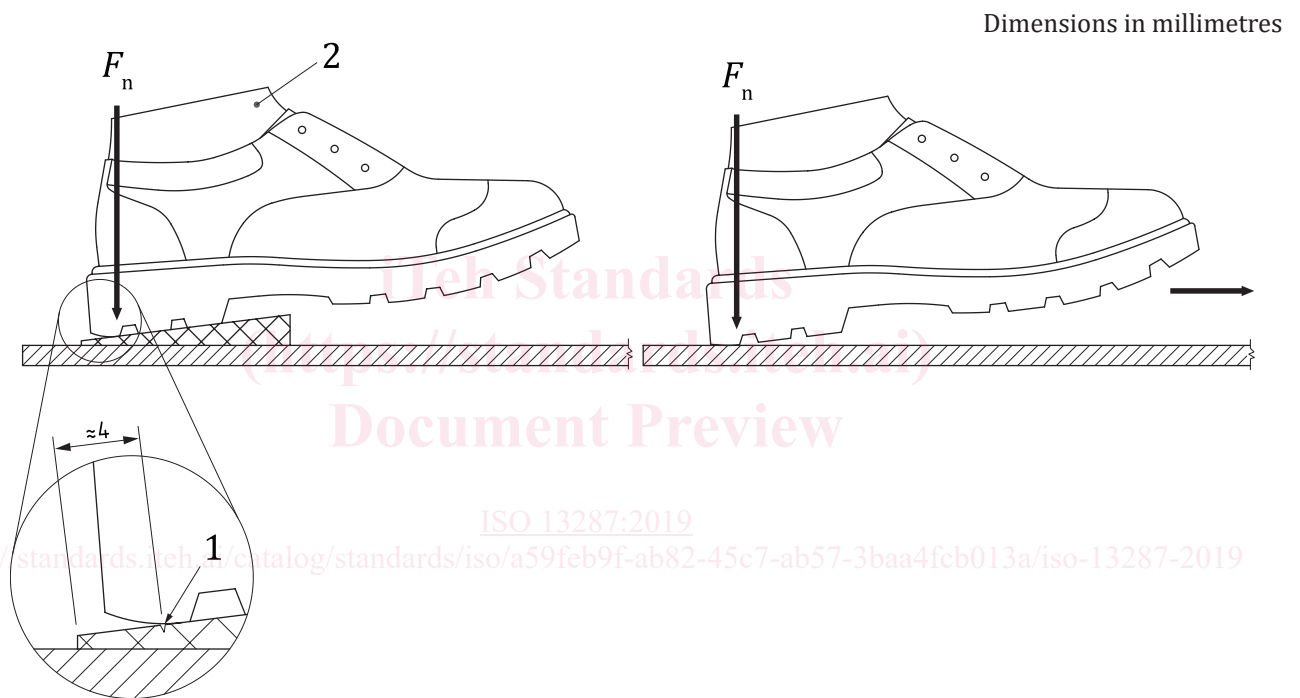

a) Forward heel slip using standard or manufacturer's shoemaking last