**Rubber, vulcanized or
thermoplastic — Determination of
hardness —**

**Part 1:
Introduction and guidance**

iTeh STANDARD PREVIEW
(standards.iteh.ai)
*Caoutchouc vulcanisé ou thermoplastique — Détermination de la
dureté —
Partie 1: Introduction et lignes directrices*

ISO 48-1:2018

<https://standards.iteh.ai/catalog/standards/sist/deadf7a8-12a1-4117-a0e7-d64a1238c370/iso-48-1-2018>



iTeh STANDARD PREVIEW
(standards.iteh.ai)

ISO 48-1:2018

<https://standards.iteh.ai/catalog/standards/sist/deadf7a8-12a1-4117-a0e7-d64a1238c370/iso-48-1-2018>



COPYRIGHT PROTECTED DOCUMENT

© ISO 2018

All rights reserved. Unless otherwise specified, or required in the context of its implementation, no part of this publication may be reproduced or utilized otherwise in any form or by any means, electronic or mechanical, including photocopying, or posting on the internet or an intranet, without prior written permission. Permission can be requested from either ISO at the address below or ISO's member body in the country of the requester.

ISO copyright office
CP 401 • Ch. de Blandonnet 8
CH-1214 Vernier, Geneva
Phone: +41 22 749 01 11
Fax: +41 22 749 09 47
Email: copyright@iso.org
Website: www.iso.org

Published in Switzerland

Contents

	Page
Foreword	iv
Introduction	v
1 Scope	1
2 Normative references	1
3 Terms and definitions	1
4 Indentation hardness	2
5 Types of hardness test	2
6 Significance	3
7 Uses of hardness tests	3
8 Choice of methods	3
9 Test piece	4
10 Standard hardness blocks	4
11 Comparison of hardness scales	4
Bibliography	5

iTeh STANDARD PREVIEW (standards.iteh.ai)

[ISO 48-1:2018](https://standards.iteh.ai/catalog/standards/sist/deadf7a8-12a1-4117-a0e7-d64a1238c370/iso-48-1-2018)

<https://standards.iteh.ai/catalog/standards/sist/deadf7a8-12a1-4117-a0e7-d64a1238c370/iso-48-1-2018>

Foreword

ISO (the International Organization for Standardization) is a worldwide federation of national standards bodies (ISO member bodies). The work of preparing International Standards is normally carried out through ISO technical committees. Each member body interested in a subject for which a technical committee has been established has the right to be represented on that committee. International organizations, governmental and non-governmental, in liaison with ISO, also take part in the work. ISO collaborates closely with the International Electrotechnical Commission (IEC) on all matters of electrotechnical standardization.

The procedures used to develop this document and those intended for its further maintenance are described in the ISO/IEC Directives, Part 1. In particular, the different approval criteria needed for the different types of ISO documents should be noted. This document was drafted in accordance with the editorial rules of the ISO/IEC Directives, Part 2 (see www.iso.org/directives).

Attention is drawn to the possibility that some of the elements of this document may be the subject of patent rights. ISO shall not be held responsible for identifying any or all such patent rights. Details of any patent rights identified during the development of the document will be in the Introduction and/or on the ISO list of patent declarations received (see www.iso.org/patents).

Any trade name used in this document is information given for the convenience of users and does not constitute an endorsement.

For an explanation of the voluntary nature of standards, the meaning of ISO specific terms and expressions related to conformity assessment, as well as information about ISO's adherence to the World Trade Organization (WTO) principles in the Technical Barriers to Trade (TBT) see the following URL: www.iso.org/iso/foreword.html. (standards.iteh.ai)

This document was prepared by Technical Committee ISO/TC 45, *Rubber and rubber products*, Subcommittee SC 2, *Testing and analysis*. ISO 48-1:2018

This first edition of ISO 48-1 cancels and replaces ISO 18517:2015, of which it constitutes a minor revision. The changes compared to the previous edition are as follows:

- a new standard number has been given.
- in the Introduction, an explanation of the purpose of the grouping work has been added.

A list of all parts in the ISO 48 series can be found on the ISO website.

Any feedback or questions on this document should be directed to the user's national standards body. A complete listing of these bodies can be found at www.iso.org/members.html.

Introduction

ISO/TC 45/SC 2 established a principle that it would be helpful for users if standards on the same subject but covering different aspects or methods were grouped together, preferably with an introductory guidance standard, rather than being scattered throughout the numbering system. This has been achieved for some subjects, for example curemeters (ISO 6502) and dynamic properties (ISO 4664).

In 2017, it was decided to group standards for hardness and, subsequently, it was agreed that they would be grouped under the ISO 48 number. The new standards together with the previously numbered standards are listed below.

- ISO 48-1: former ISO 18517
- ISO 48-2: former ISO 48
- ISO 48-3: former ISO 27588
- ISO 48-4: former ISO 7619-1
- ISO 48-5: former ISO 7619-2
- ISO 48-6: former ISO 7267-1
- ISO 48-7: former ISO 7267-2
- ISO 48-8: former ISO 7267-3
- ISO 48-9: former ISO 18898

ITEH STANDARD PREVIEW
(standards.iteh.ai)

[ISO 48-1:2018](https://standards.iteh.ai/catalog/standards/sist/deadf7a8-12a1-4117-a0e7-d64a1238c370/iso-48-1-2018)

<https://standards.iteh.ai/catalog/standards/sist/deadf7a8-12a1-4117-a0e7-d64a1238c370/iso-48-1-2018>

iTeh STANDARD PREVIEW
(standards.iteh.ai)

ISO 48-1:2018

<https://standards.iteh.ai/catalog/standards/sist/deadf7a8-12a1-4117-a0e7-d64a1238c370/iso-48-1-2018>

Rubber, vulcanized or thermoplastic — Determination of hardness —

Part 1: Introduction and guidance

1 Scope

This document provides guidance on the determination of the hardness of vulcanized and thermoplastic rubbers.

It is intended to provide an understanding of the significance of hardness as a material property and to assist in the selection of an appropriate test method.

2 Normative references

There are no normative references in this document.

3 Terms and definitions

For the purposes of this document, the following terms and definitions apply.

ISO and IEC maintain terminological databases for use in standardization at the following addresses:

- ISO Online browsing platform: available at <https://www.iso.org/obp>
- IEC Electropedia: available at <https://www.electropedia.org/>

3.1 international rubber hardness degrees

IRHD

hardness scale chosen so that “0” represents the hardness of material having a Young’s modulus of zero and “100” represents the hardness of a material of infinite Young’s modulus

Note 1 to entry: The following conditions are fulfilled over most of the normal range of hardness:

- a) one international rubber hardness degree always represents approximately the same proportional difference in Young's modulus;
- b) for highly elastic rubbers, the IRHD and Shore A scales are comparable.

3.2 standard hardness

S

hardness, in international rubber hardness degrees, obtained using the procedures described in ISO 48-2 on test pieces of the standard thickness and not less than the minimum lateral dimensions specified

3.3 apparent hardness

hardness, in international rubber hardness degrees, obtained using the procedures described in ISO 48-2 on test pieces of non-standard dimensions

4 Indentation hardness

The term hardness when applied to rubbers refers to a measure of stiffness obtained from an indentation test. An indenter is pressed into the rubber under a given force and the resulting indentation measured as illustrated in [Figure 1](#). In contrast to some methods for other materials, the indentation is measured with the load applied.

In most tests, the indenter is surrounded by a foot which rests on the test piece under a given force. In dead-load tests (see [Clause 5](#)), the measured indentation is the difference between the indentation caused by a small initial force and that caused by a larger final force.

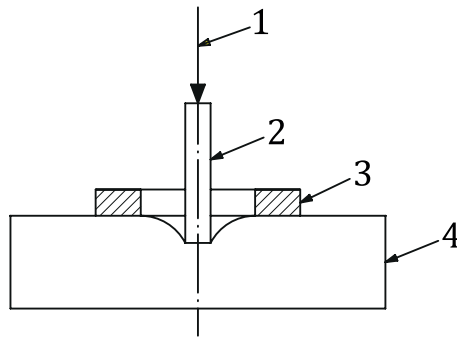

Key

- 1 weight or spring to apply force
- 2 indenter
- 3 pressure foot
- 4 test piece

iTeh STANDARD PREVIEW
(standards.iteh.ai)

Figure 1 — Principle of hardness test
ISO 48-1:2018
<https://standards.iteh.ai/catalog/standards/sist/deadf7a8-12a1-4117-a0e7-d64a1238c370/iso-48-1-2018>

5 Types of hardness test

Distinction is made between dead-load tests, where the indenting force is produced by a weight, and so-called durometers or pocket hardness meters, where the indenting force is applied by a spring.

Dead-load methods using a ball indenter with hardness expressed in international rubber hardness degrees (IRHD) are specified in ISO 48-2. This hardness scale is based on the relationship defined in [3.1](#) and a probit curve relating $\log_{10}(\text{modulus})$ to the hardness in IRHD. This results in a scale from 0 to 100 for infinitely soft to infinitely rigid materials. The definition of IRHD was chosen to give reasonable agreement with the Shore A scale described below.

The “normal” dead-load method is intended for use with rubbers in the range 35 IRHD to 85 IRHD and there are modifications for low-hardness and high-hardness rubbers. Method L covers the hardness range from 10 IRHD to 35 IRHD and method H covers the range from 85 IRHD to 100 IRHD. The micro dead-load method is for use on thin test pieces and uses an indenter with diameter one-sixth of that for the “normal” method.

ISO 48-2 also specifies modified procedures for use on curved test pieces, with the result being expressed as apparent hardness.

A dead-load method for very soft materials using the very low rubber hardness scale (VLRH) is specified in ISO 48-3. This covers a range from about 30 IRHD to below 10 IRHD and the relation between VLRH and depth of indentation is linear.

For rubber rollers, the Pusey and Jones dead-load instrument is specified in ISO 48-8 in addition to ISO 48-2 and durometer methods in ISO 48-6 and ISO 48-7, respectively.

Durometers were originally intended to be hand-held but are now often mounted on a stand with a weight to apply the correct foot pressure. The best known are the Shore gauges, of which there are several different types to cover a range of materials, and which have been produced by a number of manufacturers. Shore A scale durometers for rubbers in the normal hardness range and D scale durometers for hard materials are standardized in ISO 48-4 together with a micro instrument designated AM and an instrument for soft materials designated AO. The type A uses a truncated cone indenter, types D and AM use a radiused cone, while type AO uses a ball indenter. ISO 48-5 specifies a pocket meter with a ball indenter designed to read in the IRHD scale.

6 Significance

In principle, hardness can be related to the modulus of the rubber and empirical formulae can be found in textbooks. A relationship for ball indentation is given in ISO 48-2 together with graphs of hardness against $\log(\text{modulus})$. The relationship is only valid for a perfectly elastic rubber, and in practice, can only be considered as approximate.

Because of the tenuous relation with Young's or shear modulus, hardness cannot be considered as a fundamental material property. However, because of the simplicity and cheapness of hardness testing together with its essentially non-destructive nature, hardness is universally used as a convenient measure of stiffness.

A limitation which is not always appreciated is the discrimination and precision obtainable. Generally, the best that can be achieved is ± 1 IRHD which translates to the order of ± 4 % modulus in the middle of the scale and ± 16 % at very low and high hardnesses.

iTeh STANDARD PREVIEW

7 Uses of hardness tests (standards.iteh.ai)

Hardness is a measure of stiffness or modulus which is an important property of rubbers in almost all applications. Its enormous popularity is due to its practical simplicity, versatility in terms of the test piece required, cheapness, and non-destructive nature. Because of this, it is universally used as a quality control test for trouble shooting, as a classification parameter for both compounds and products and as a requirement in material and product specifications. Hardness is widely used as a convenient, non-destructive measure of the state and uniformity of cure of a range of vulcanized products. It can also be used to track ageing, contamination and porosity, and so is suitable for diagnostic purposes.

8 Choice of methods

When a portable, hand-held instrument is needed, for example for testing products, then a spring-loaded durometer or pocket hardness meter is used. The type A durometer is by far the most popular, but the type AO and the IRHD pocket meter have the advantage of a ball indenter which is less prone to damage than a truncated cone. The IRHD pocket hardness meter also has a very low variation in spring force over the hardness range and the results correspond directly to those obtained with dead-load instruments. For very hard rubbers and thin test pieces, types D and AM, respectively, are appropriate. The Shore D scale is usually associated with plastics materials, but is in common use for harder thermoplastic elastomers and ebonite and is sometimes preferred over Shore A and IRHD scales for rubbers over 90 IRHD.

NOTE Durometers have been produced with a built-in device that guarantees the application of the correct foot pressure regardless of the force applied by the operator.

The dead-load methods are intended to be the preferred approach for standard test pieces in the laboratory, the micro dead-load method being used where only thin pieces of material are available. The high and low hardness scales are intended to improve the discrimination at the extremes of the scale, but it has been shown that, for the high scale at least, there is no advantage (for further details, see Reference [9]). The VLRH method is preferred for very soft materials.

The rationale for using the dead-load instruments is that, a weight gives a constant force and is more stable than a spring. A systematic evaluation of the parameters affecting precision has shown that the