



Designation: D2559 – 10a

Standard Specification for Adhesives for Bonded Structural Wood Products for Use Under Exterior Exposure Conditions¹

This standard is issued under the fixed designation D2559; the number immediately following the designation indicates the year of original adoption or, in the case of revision, the year of last revision. A number in parentheses indicates the year of last reapproval. A superscript epsilon (ϵ) indicates an editorial change since the last revision or reapproval.

This standard has been approved for use by agencies of the Department of Defense.

INTRODUCTION

This specification, which was initially approved in 1966, was developed to ensure that adhesives developed and used in structural glued laminated timber (glulam) are considered suitable for the intended application. This would include, as a maximum level of severity in the case of moisture effects, full and continuous exposure to the weather in a salt water marine environment.

The use of adhesives for structural wood products (that is, Engineered Wood Products) has expanded beyond Glulam to include products such as Structural Composite Lumber, wood I-Joists and various composites adhesively bonded using a variety of materials. Although most structural glued wood products have traditionally specified an adhesive suitable for exterior exposure, the actual exposure of glued wood products to exterior conditions may range from exposure to the weather for brief periods of time, to continuous exposure to a marine environment. The wide range of possible exterior exposures of the adhesively bonded structural wood product requires consideration of differing performance requirements for the adhesive.

A distinction between adhesive certification and product performance requirements is necessary to ensure the broadest possible acceptance of adhesive systems to the engineered wood products industry.

1. Scope*

1.1 This specification covers adhesives suitable for the bonding of wood, including treated wood, into structural wood products for general construction or other uses where a high-strength, durable adhesive bond is required.

1.2 This specification includes test methods that may be referenced by specific product standards for the evaluation and approval of structural wood adhesives. Methods are included to evaluate adhesives intended for use in exterior exposure, which are characterized and defined by two distinct service classes as described in 1.3.

NOTE 1—Consult the Commentary in Appendix X1 regarding the intent and limitations of each test method contained in this specification.

1.3 *Description of Bondline Performance*—It is recognized that structural wood adhesives are used in various applications and under various levels of severity in terms of moisture content, loading, cyclic and seasonal weather conditions, heat exposure and other use conditions. It is the intent of this

standard to determine the suitability of an adhesive for use under various levels of severity and conditions of use in accordance with specific and appropriate test methods and requirements. For use in this standard, structural wood adhesives are separated into two classes described in terms of conditions of use, and severity of environmental exposure including the amount of moisture.

NOTE 2—This standard does not contain specific tests outlined for different chemical types of adhesives.

1.3.1 *Description of Adhesive Service Class A*—This service class is characterized by its limited exposure to the weather, including low moisture content conditions and is sometimes referred to as a Protected Service or Limited Moisture Exposure environment. In this service class, exposure of adhesive bondlines in structural wood products to exterior environment is limited to those such as during transportation, construction and accidental exposure where the material may be subjected to a limited number of cycles of short-term wetting and drying.

1.3.2 *Description of Adhesive Service Class B*—This service class is described wherein adhesive bondlines in structural wood products are subjected to full and repeated or continuous exposure to the weather including high moisture content

¹ This specification is under the jurisdiction of ASTM Committee D14 on Adhesives and is the direct responsibility of Subcommittee D14.30 on Wood Adhesives.

Current edition approved Sept. 1, 2010. Published October 2010. Originally approved in 1966. Last previous edition approved in 2010 as D2559 – 10. DOI: 10.1520/D2559-10A.

*A Summary of Changes section appears at the end of this standard.

conditions. This exposure may include fresh and saltwater marine applications as well as possible ground contact. This service class has traditionally been referred to as Exterior or Wet Service.

NOTE 3—While the two adhesive service classes for structural wood adhesives are described or characterized in 1.3.1 and 1.3.2 the definitions for Adhesive Service Class A and Adhesive Service Class B adhesives are found in Terminology 3.2.2 and 3.2.3 respectively.

1.4 Strength and durability requirements of the adhesive in Service Class A are based on the performance of the adhesive in laminated wood as measured by:

1.4.1 Resistance to shear by compression loading after conditioning to the target moisture content indicated in 14.2.3 and meeting requirements in 14.4.

1.4.2 Resistance to delamination during exposure to three cycles of vacuum pressure wetting followed by drying at elevated temperature as indicated in 15.3 and meeting requirements in 15.4.

1.4.3 Resistance to creep under static load by subjecting test specimens to a specified shear stress and exposing one set of test specimens to an environment of elevated temperature and ambient humidity and another set to an environment of high humidity and meeting requirements set forth in 16.3.

1.5 Strength and durability requirements of the adhesive in Service Class B are those listed in 1.4 and in addition shall include:

1.5.1 Conducting supplemental durability testing in accordance with Section 17. The supplemental durability testing shall be completed using either Test Method D3434 or CSA O112.9-10, Clause 5.5 as set forth in 17.2 and meeting requirements in 17.3 (Note 4).

NOTE 4—Test Method D3434 and CSA O112.9-10, Clause 5.5 are both considered sufficient to demonstrate a higher level of adhesive durability required and consistent with the indicated service environment. Although both methods are considered sufficient to demonstrate a higher measured level of adhesive durability, no documented level of equivalency with the two methods is stated or implied.

1.5.2 For marine applications the adhesive shall be evaluated in accordance with Section 15 using salt water.

1.5.3 For applications involving chemical treatment, the adhesive shall be evaluated in accordance with Sections 14-17 using representative samples of treated wood.

NOTE 5—When using chemically treated wood, compatibility between the treatment, adhesive, and wood is to be considered and agreed upon between the chemical manufacture and the user.

NOTE 6—Additional durability testing may also be required as specified by individual product standards. Consult the Commentary in Appendix X1 for additional information and guidance as to the type of durability testing that may be appropriate to supplement this specification when characterizing the adhesive for suitability with specific wood products.

1.6 The evaluation of binder adhesives is beyond the scope of this specification.

1.7 The values stated in SI units are to be regarded as the standard. The values in parentheses are for information only.

1.8 The text of this specification references notes, footnotes and a commentary which provide explanatory material. These

notes, footnotes and commentary (excluding those in tables and figures) shall not be considered as requirements of the specification.

1.9 *This standard does not purport to address all of the safety concerns, if any, associated with its use. It is the responsibility of the user of this standard to establish appropriate safety and health practices and determine the applicability of regulatory limitations prior to use.*

2. Referenced Documents

2.1 ASTM Standards:²

- D9 Terminology Relating to Wood and Wood-Based Products
 - D143 Test Methods for Small Clear Specimens of Timber
 - D905 Test Method for Strength Properties of Adhesive Bonds in Shear by Compression Loading
 - D907 Terminology of Adhesives
 - D1165 Nomenclature of Commercial Hardwoods and Softwoods
 - D1583 Test Method for Hydrogen Ion Concentration of Dry Adhesive Films
 - D2555 Practice for Establishing Clear Wood Strength Values
 - D3434 Test Method for Multiple-Cycle Accelerated Aging Test (Automatic Boil Test) for Exterior Wet Use Wood Adhesives
 - D3535 Test Method for Resistance to Creep Under Static Loading for Structural Wood Laminating Adhesives Used Under Exterior Exposure Conditions
 - D4442 Test Methods for Direct Moisture Content Measurement of Wood and Wood-Base Materials
 - D4300 Test Methods for Ability of Adhesive Films to Support or Resist the Growth of Fungi
 - D5055 Specification for Establishing and Monitoring Structural Capacities of Prefabricated Wood I-Joists
 - D5266 Practice for Estimating the Percentage of Wood Failure in Adhesive Bonded Joints
 - D5456 Specification for Evaluation of Structural Composite Lumber Products
 - E6 Terminology Relating to Methods of Mechanical Testing
 - E41 Terminology Relating To Conditioning
 - E691 Practice for Conducting an Interlaboratory Study to Determine the Precision of a Test Method
- ### 2.2 Other Documents:
- CSA O112.9-10 Evaluation of Adhesives for Structural Wood Products (Exterior Exposure)³

3. Terminology

3.1 *Definitions*—Many terms in this specification are defined in Terminologies D9 and D907.

3.2 *Definitions of Terms Specific to This Standard:*

² For referenced ASTM standards, visit the ASTM website, www.astm.org, or contact ASTM Customer Service at service@astm.org. For *Annual Book of ASTM Standards* volume information, refer to the standard's Document Summary page on the ASTM website.

³ Available from Canadian Standards Association (CSA), 5060 Spectrum Way, Mississauga, ON L4W 5N6, Canada, <http://www.shopcsa.ca>.

3.2.1 *Adhesive Service Class, n*—a classification mechanism to describe bondline performance at a specific moisture condition or to definitively indicate the design moisture class for a structural adhesive.

3.2.2 *Adhesive Service Class A, n*—a combination of temperature and humidity conditions that would result in a moisture content in solid lumber not exceeding 16 % for a few weeks per year.

3.2.3 *Adhesive Service Class B, n*—environmental conditions where exposure to a combination of temperature and moisture exposure situations would result in a moisture content in solid lumber that frequently or continuously exceeds 16 %.

3.2.4 *delamination, n*—the separation of layers in a laminate because of failure of the adhesive, either in the adhesive itself or at the interface between the adhesive and the adherend.

3.2.5 *engineered wood product, n*—a product consisting of a combination of smaller wood-based components bonded together using a structural adhesive and designed using engineering methods; an alternative to traditional sawn lumber.⁴

NOTE 7—The following ASTM standards may be referred to for other terms used in this specification: Nomenclature **D1165**, and Terminologies **D9**, **E6**, and **E41**.

3.2.6 *exterior exposure, n*—service environment that cause physical and chemical changes similar to that observed from weathering in which a wood product, including any adhesive bondlines, is subjected to weathering, including but not limited to: rain, snow, heat, cold and ultraviolet radiation and their cyclic or seasonal effects.

3.2.7 *glulam, n*—synonym for *structural-glued-laminated timber*.

3.2.8 *structural-glued-laminated timber, n*—an engineered stress-rated product of a timber laminating plant comprising assemblies of specially selected and prepared wood laminations securely bonded together with adhesives, with the following characteristics: (1) the grain of all laminations is approximately parallel longitudinally; and (2) the laminations may be comprised of pieces end-joined to form any length, of pieces placed or glued edge-to-edge to make wider ones or of pieces bent to curved form during gluing. (Synonym: *glulam*) ANSI/AITC A190.1–2007. American National Standard for Wood Products—Structural Glued Laminated Timber (edited to conform with ASTM format).

3.2.9 *weathering, n*—a complex series of physical and chemical changes occurring in wood products, including but not limited to, checking, dimension stability and chemical decomposition as well as a change in adhesive bondline integrity related to the natural swelling and shrinking stresses when exposing to the natural elements such as air, water, light and man-made pollutants.⁵

4. Significance and Use

4.1 Structural design based on strength of material principles of the structural components, including the adhesive and

the adhesive's potential durability, requires that the suitability for structural exterior exposure be predicted.

4.2 Performance of the adhesive for resistance to shear by compression loading, resistance to delamination during accelerated aging, exposure to wetting and drying, and resistance to creep under load data developed by this test aid in determining if the adhesive is suitable for use in structural wood products under conditions of exterior exposure.

4.3 Minimum test requirements shall be associated with Adhesive Service Class A following test methods in Sections 14-16.

4.4 Additional durability tests are required to fully identify the suitability of the adhesive in a structural wood product when used in Adhesive Service Class B. For additional details, guidance and test requirements refer to 1.4, Section 17, and the Commentary in Appendix X1.

4.5 Test methods specified in the scope of this standard are intended to provide the minimum basis for determining the suitability of an adhesive for use in exterior exposure conditions as defined by the two service classes noted.

NOTE 8—Product-specific standards should be consulted for test methods applicable to desired service conditions, and appropriate criteria in context with anticipated in-service product performance requirements.

4.6 Test methods indicated for approval and certification of adhesives in each of the specified service classes can be useful to adhesive manufacturers, testing laboratories, quality control agencies, architects, specifiers, other professionals and the general public.

4.7 The suitability of adhesive systems for use in the manufacture of engineered wood products for exterior applications is dependent on both the adhesive certification test requirements specified in D2559, and performance requirements provided in specific product standards.

4.8 This specification does not purport to address all test criteria required to fully identify the suitability of the adhesive in a structural wood product.

5. Classification

5.1 The manufacturer shall classify the adhesive as to general type. Typical classifications include: resorcinol, phenol-resorcinol, phenol, melamine, etc.

5.2 The manufacturer may be considered to be the testing facility certifying the adhesive.

6. Ordering Information

6.1 The manufacturer will furnish the adhesive in any suitable form agreeable to the purchaser.

7. Fillers and Extenders

7.1 If amylaceous or protein fillers and extenders are used, the adhesive must not only pass requirements of this specification, but in addition, possess sufficient antifungal properties to inhibit the growth of selected fungal species when tested in accordance with Test Methods **D4300**. The adhesive manufacturer shall state in his bulletin whether such materials are present.

⁴ American Forest and Paper Association, American Wood Council, *Engineered Wood Products – At a Glance*, <http://www.woodaware.info/guideewp.html>.

⁵ Feist, W. C. and Hon, D. N.-S., *Chemistry of Weathering and Protection of Wood*, in R. Rowell (Ed.). *The Chemistry of Solid Wood*, American Chemical Society, Washington, DC, 1984, Chapter 11.

8. Chemical Requirements

8.1 The cured adhesive film shall develop a pH value of not less than 2.5 when tested in accordance with Test Method **D1583**.

9. Physical Requirements

9.1 The adhesive manufacturer shall furnish written instructions stating the general chemical type of adhesive, its storage and mixing procedure, the method of wood preparation, and any other data which is pertinent to the use of the adhesive in the manufacture of laminated wood products.

9.2 The adhesive must pass the tests required by this specification for all limiting conditions recommended in the manufacturer's bulletin. The information furnished by the manufacturer should include each of the following for each species of wood included in his recommendations:

9.2.1 Limits of working life,

9.2.2 Minimum and maximum open and closed assembly times as dictated by temperature, moisture content of the wood, mix age, etc.,

9.2.3 Minimum spread rates for assembly times and use conditions as indicated in **9.2.2**,

9.2.4 Minimum cure time and temperature of bondline for complete cure,

9.2.5 Minimum pressure, and

9.2.6 Maximum and minimum allowable moisture content of the wood.

10. Selection and Preparation of Wood for Testing of Adhesives

10.1 Test the adhesive on the species of wood to be bonded or for which it is recommended including chemically treated wood (see **Note 9**). The wood shall have a maximum slope of grain of 1 in 15 on any face or any edge. The wood shall

contain no knots larger than 3 mm ($\frac{1}{8}$ in.) in diameter and shall be free from decay, machining defects (such as chipped grain, dubbed ends, feed roll polish, coarse knife marks, and feed roll compression), and any drying defects such as case hardening, collapse, splits, or checks. Use only flat-grained wood.

NOTE 9—Grouping of species is not permitted.

10.2 Wood Moisture Content:

10.2.1 *Ambient Curing Adhesives*—Condition the wood at $23 \pm 2^\circ\text{C}$ ($73.4 \pm 3.6^\circ\text{F}$) and a relative humidity of 50 to 70 % (preferably 65 %) until a moisture content of 8 to 14 % or, preferably 9 to 12 %, has been attained.

10.2.2 *Hot Press Curing Adhesives*—Condition the wood at $23 \pm 2^\circ\text{C}$ ($73.4 \pm 3.6^\circ\text{F}$) and a relative humidity of less than 50 % until a moisture content of 3 to 8 % has been attained.

10.3 Freshly surface each lamination before bonding with the adhesive to be tested. Remove at least 0.4 mm ($\frac{1}{64}$ in.) from each face within 24 h of bonding. The machining tolerances for each lamination used in preparing the test samples shall be no greater than ± 0.25 mm (0.01 in.) between laminations and ± 0.20 mm (0.008 in.) within laminations.

11. Preparation of Laminated Wood Test Members

11.1 Ambient-Curing Adhesives:

11.1.1 Prepare six pieces of wood of the same species for each laminated wood member. Each of the six pieces shall have a specific gravity equal to or exceeding the minimum requirement of **Table 1**. Each piece of wood shall be 19-mm (0.75-in.) thick lumber (see **Note 10**) at least 140 mm ($5\frac{1}{2}$ in.) in width and 1 m (40 in.) long. Orient the direction of the annular growth rings when viewed on the end of the laminations in the laminated wood test member so that they are alternated.

NOTE 10—This thickness would normally come from “nominal 1-in. lumber.”

TABLE 1 Required Shear Strength for Structural Laminated Wood Products

NOTE 1—For species other than those given, strength values shall be based on 90 % of the value for shear parallel to grain at 12 % moisture content. The use of 90 % of shear parallel to grain at 12 % moisture content takes into account the various subspecies of a particular wood species. The values for shear parallel to grain may be found in Tables 4-3a through 4-4b of the Wood Handbook, Forest Products Society (1999 edition). Base the minimum allowable specific gravity on volume for wood at 12 % moisture content. For species not listed see **Note 3**. Adjustments for changes in moisture content shall be made in accordance with formula 4-3 (page 4-34) found in the 1999 Wood Handbook.

NOTE 2—It has been documented that bonded shear specimens (Test Method **D905** type specimen) on the average provide higher shear strength values than solid wood specimens (Test Methods **D143** type specimen). It may appear to be inconsistent to compare shear strength data of bonded specimens to data based on 90 % of the solid wood shear strength found in the Wood Handbook. However, the goal of evaluating shear strength of adhesives in Specification D2559 is to demonstrate the shear strength in a laminated product (tested using Test Method **D905** type specimens) meets or exceeds the strength of a solid wood beam when tested by standard procedures for solid wood (Test Methods **D143** type specimen).

NOTE 3—For species not found in the 1999 Wood Handbook, values for shear parallel to grain at 12 % moisture content using solid wood are to be obtained on clear, straight-grained specimens following specific ASTM test methods and procedures. These include Test Methods **D143** and Practice **D2555**. Test Methods **D143** testing is to be performed on a minimum of 28 shear strength specimens.

Species	Required Shear Strength, KPa (psi) ^A			Minimum Allowable Specific Gravity of Solid Wood Used for Each Lamination ^B
	Moisture Content of Wood at Test			
	8 %	12 %	16 %	
Douglas fir	7 600 (1 110)	7 000 (1 020)	6 500 (940)	0.43
Hemlock, western	8 900 (1 290)	8 000 (1 160)	7 200 (1 050)	0.41
Larch, western	9 400 (1 370)	8 400 (1 220)	7 600 (1 100)	0.55
Oak, white	14 300 (2 080)	12 400 (1 800)	11 000 (1 560)	0.68
Pine, southern	10 400 (1 510)	8 600 (1 250)	7 100 (1 040)	0.51
Redwood	6 300 (910)	5 800 (850)	5 400 (790)	0.40

^A Based on 90 % of the shear strength parallel to grain at 12 % moisture content from Table 4-3 of the 1999 Wood Handbook. Use the same shear strength values for a specific species when chemically treated wood is used.

^B Based on weight when oven dry and volume at 12 % moisture content.

11.1.1.1 As an alternative to the preparation of laminated wood test members 1 m (40 in.) in length, prepare duplicate 610-mm (24-in.) laminated wood members to obtain at least an equivalent number of test specimens. This alternative includes the preparation of separate two-ply assemblies for evaluation in accordance with 1.4.1 using Test Method D905 block shear specimens that may be used as an alternate to stair-step specimens.

11.1.2 Apply the adhesive uniformly to the contacting faces of each lamination in accordance with the manufacturer's instructions.

11.1.3 Place the laminated wood members under pressure for a period of time and at the bondline temperature specified by the manufacturer of the adhesive.

11.1.4 *Conditioning*—Condition the laminated wood members at $23 \pm 2^\circ\text{C}$ ($73.4 \pm 3.6^\circ\text{F}$) and a relative humidity of 50 to 70 % (preferably 65 %) for the minimum time recommended by the manufacturer for each curing temperature used during the pressure period, and test immediately.

11.2 *Hot-Press Curing Adhesives:*

11.2.1 Prepare six pieces of wood of the same species for each laminated test member. Each of the six pieces shall have a specific gravity equal to or exceeding the minimum requirement of Table 1. Each piece of wood shall be 19 mm (0.75 in.) thick lumber (see Note 11) at least 140 mm (5½ in.) in width and 1 m (40 in.) long as allowed in 11.1.1.1. Orient the direction of the annular growth rings when viewed on the end of the laminations in the laminated wood test member so that they are alternated.

NOTE 11—This thickness would normally come from “nominal 1 in. lumber.”

11.2.1.1 As an alternative to the preparation of laminated wood test members 1 m (40 in.) in length, prepare duplicate 610-mm (24-in.) laminated wood members to obtain at least an equivalent number of test specimens. This alternative includes the preparation of separate two-ply assemblies for evaluation in accordance with 1.4.1 using Test Method D905 block shear specimens that may be used as an alternate to stair-step specimens.

11.2.2 Apply the adhesive uniformly to the contacting faces of each lamination in accordance with the manufacturer's instructions.

11.2.3 Hot press three-layer assemblies at the pressure, press temperature, and to the bondline temperature specified by the manufacturer of the adhesive. These three-layer assemblies, after conditioning in accordance with 11.1.4, are assembled into six laminated wood test members using a Specification D2559 approved ambient-curing adhesive for the center bondline in accordance with 11.1.3.

11.2.4 *Conditioning*—Condition the laminated wood members at $23 \pm 2^\circ\text{C}$ ($73.4 \pm 3.6^\circ\text{F}$) and a relative humidity of 50 to 70 % (preferably 65 %) for the minimum time recommended by the manufacturer for each curing temperature used during the pressure period, and test immediately.

12. Number of Tests

12.1 Prepare six laminate wood members for tests, one at each of the limiting conditions listed, but all other factors, as itemized in 9.1 and 9.2, shall be in accordance with the manufacturer's instructions.

12.1.1 Liquid adhesives:

12.1.1.1 Minimum open assembly time with minimum closed assembly time,

12.1.1.2 Maximum open assembly time with maximum closed assembly time, and

12.1.1.3 Minimum open assembly time with maximum closed assembly time.

12.1.2 Film adhesives:

12.1.2.1 Minimum cure time,

12.1.2.2 Minimum cure temperature, and

12.1.2.3 Minimum pressure.

13. Preparation of Test Specimens

13.1 Dress the laminated wood members, prepared in accordance with Sections 11 and 12, on the sides to a uniform width of 127 mm (5 in.) at the completion of the conditioning period. Trim 76 mm (3 in.) off one end of each of these members and discard it. Cut the remaining trimmed members into five sections as shown in Fig. 1. Use the 102-mm (4-in.) sections labeled “A” for conducting tests in resistance to shear by compression loading in accordance with Section 14, and use the 254-mm (10-in.) sections labeled “B” for conducting resistance to delamination tests in accordance with Section 15. Discard the remaining waste trim portion.

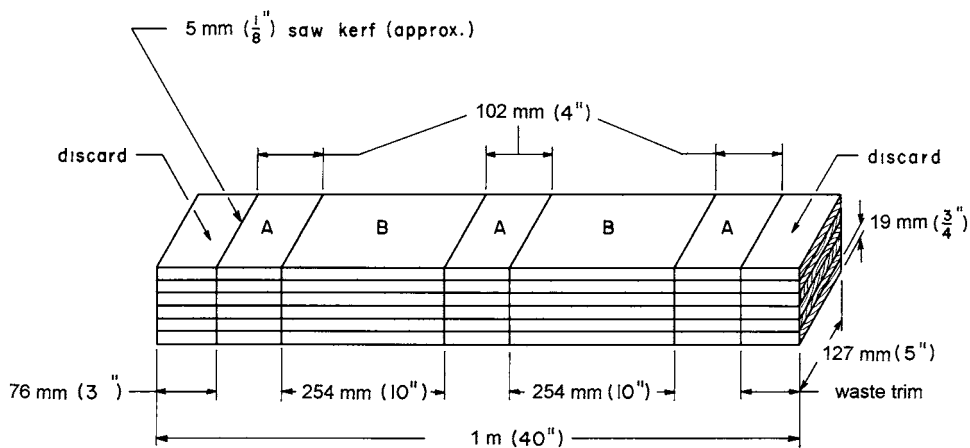

FIG. 1 Laminated Test Beam

13.1.1 If duplicate laminated wood members are made in accordance with 11.1.1.1 or 11.2.1.1 to obtain at least an equivalent number of test specimens, then trim 51 mm (2 in.) off each end. Utilize the remaining trimmed member, 508 mm (20 in.) in length by cutting two 254-mm (10-in.) sections labeled “B” or one 254-mm section “B” and two 102-mm (4-in.) sections “A” as shown in Fig. 1. If two “B” sections are prepared then make separate specimens for shear testing by preparing two-layer laminated wood members and specimens in accordance with Test Method D905 and 11.1.1.1 and 11.2.1.1. Make and test these specimens from the same species of wood, at exactly the same time, and under the same conditions as required for other test samples in this specification.

TEST METHODS — ADHESIVE SERVICE CLASS A

14. Resistance to Shear by Compression Loading

14.1 *Apparatus*—The testing machine capacity is to be of about 66900 N (15 000 lb) in compression or of sufficient capacity to test the species of wood in use. Equip the testing machine with a shearing tool containing a self-aligning seat to ensure uniform lateral distribution of the load. The machine shall be capable of maintaining a uniform rate of loading such that the load is applied with a continuous motion of the movable head to a maximum rate load not to exceed 13-mm (0.50-in.)/min. The shearing tool shown in Fig. 1 of Test Method D905 has been found satisfactory. Locate the testing machine in an atmosphere such that the moisture content of the test pieces developed in accordance with 11.1.4 is not noticeably altered during testing.

14.2 *Samples:*

14.2.1 Prepare at least six samples for testing in shear by compression loading. When stair-step shear samples are used, cut two from each of the 102-mm (4-in.) sections labeled “A” in Fig. 1. When separate two-ply laminated wood samples are made in accordance with 11.1.1.1 or 11.2.1.1 make at least six test samples and cut at least five test specimens from each as specified by the dimensions of Figs. 2 and 3 of Test Method D905.

14.2.2 The stair-step shear specimens shall conform to the form and dimensions shown in Fig. 2. Take care in preparing the test specimens to assure that the grain direction in the wood is parallel to the direction of loading during test. The loaded surfaces shall be smooth and parallel to each other and perpendicular to the height. When sawing the bonded assembly, exercise care to ensure that the saw cuts to, but not beyond, the adhesive line. Measure the width and height of the specimen at the adhesive line to the nearest 0.25 mm (0.01 in.) to determine the shear area. All requirements above shall apply when individual test specimens are cut from the separately laminated test members of Test Method D905.

14.2.3 Condition the individual test specimens in the conditioning environment described in 11.1.4 and 11.2.4 to a target moisture content of 8, 12, or 16 % for species listed in Table 1. For all other species condition to a target moisture content of 12 %. The allowable variation in the target moisture content before testing is ±1 %. Moisture content is to be determined using Test Methods D4442.

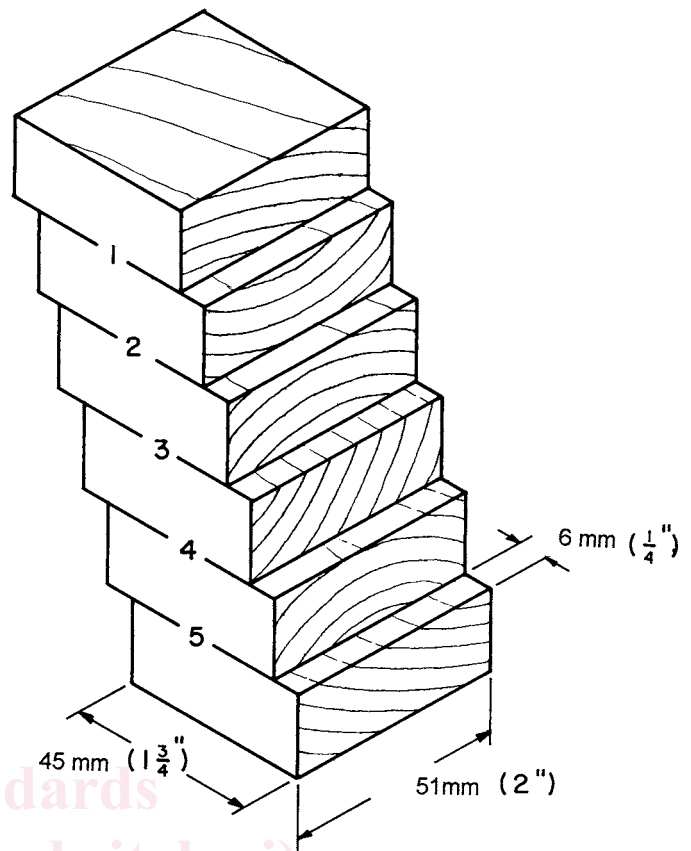

FIG. 2 Stair-Step Shear Specimen

14.3 Test the test specimens cut from the test samples described in 14.2 to failure. Report the shear strength calculated in kilopascals (kPa) (pounds per square inch (psi)) based on the bonded area between two laminations rounded to the nearest 0.0645 mm² (0.01 in.²), for each test specimen together with the estimated percentage wood failure. Practice D5266 has been found useful in estimating the percentage of wood failure in adhesive bonded joints.

14.4 *Requirements:*

14.4.1 The average shear strength for each group of laminated wood members made at one manufacturing condition as specified in Section 12, and tested as described above shall be not less than the values specified in Table 1 at the appropriate moisture content of the wood.

14.4.2 The average wood failure for each group of laminated wood members made at one condition and tested as prescribed in Section 14 shall be not less than 75 % for all species listed in Table 1.

14.5 *Retest:*

14.5.1 If the strength requirements of 14.4 are not satisfied, but the wood failure value is 95 % or more, retest the adhesive.

15. Resistance to Delamination During Accelerated Exposure

15.1 *Apparatus:*

15.1.1 An autoclave or similar pressure vessel capable of withstanding at least 550 kPa (80 psi) is required for impregnating the specimens with water. Equip the vessel with a