

# DRAFT INTERNATIONAL STANDARD

## ISO/DIS 4035

ISO/TC 2/SC 12

Secretariat: DIN

Voting begins on:  
2022-04-20

Voting terminates on:  
2022-07-13

---

---

## Fasteners — Hexagon thin nuts (style 0)

*Fixations — Écrous bas hexagonaux (style 0)*

ICS: 21.060.20

iTeh STANDARD PREVIEW  
(standards.iteh.ai)

[ISO/FDIS 4035](https://standards.iteh.ai/catalog/standards/sist/af656c8c-8102-4d89-9491-e67f2e2c985a/iso-fdis-4035)

<https://standards.iteh.ai/catalog/standards/sist/af656c8c-8102-4d89-9491-e67f2e2c985a/iso-fdis-4035>

This document is circulated as received from the committee secretariat.

THIS DOCUMENT IS A DRAFT CIRCULATED FOR COMMENT AND APPROVAL. IT IS THEREFORE SUBJECT TO CHANGE AND MAY NOT BE REFERRED TO AS AN INTERNATIONAL STANDARD UNTIL PUBLISHED AS SUCH.

IN ADDITION TO THEIR EVALUATION AS BEING ACCEPTABLE FOR INDUSTRIAL, TECHNOLOGICAL, COMMERCIAL AND USER PURPOSES, DRAFT INTERNATIONAL STANDARDS MAY ON OCCASION HAVE TO BE CONSIDERED IN THE LIGHT OF THEIR POTENTIAL TO BECOME STANDARDS TO WHICH REFERENCE MAY BE MADE IN NATIONAL REGULATIONS.

RECIPIENTS OF THIS DRAFT ARE INVITED TO SUBMIT, WITH THEIR COMMENTS, NOTIFICATION OF ANY RELEVANT PATENT RIGHTS OF WHICH THEY ARE AWARE AND TO PROVIDE SUPPORTING DOCUMENTATION.

**ISO/CEN PARALLEL PROCESSING**



Reference number  
ISO/DIS 4035:2022(E)

© ISO 2022

iTeh STANDARD PREVIEW  
(standards.iteh.ai)

ISO/FDIS 4035

<https://standards.iteh.ai/catalog/standards/sist/af656c8c-8102-4d89-9491-e67f2e2c985a/iso-fdis-4035>



**COPYRIGHT PROTECTED DOCUMENT**

© ISO 2022

All rights reserved. Unless otherwise specified, or required in the context of its implementation, no part of this publication may be reproduced or utilized otherwise in any form or by any means, electronic or mechanical, including photocopying, or posting on the internet or an intranet, without prior written permission. Permission can be requested from either ISO at the address below or ISO's member body in the country of the requester.

ISO copyright office  
CP 401 • Ch. de Blandonnet 8  
CH-1214 Vernier, Geneva  
Phone: +41 22 749 01 11  
Email: [copyright@iso.org](mailto:copyright@iso.org)  
Website: [www.iso.org](http://www.iso.org)

Published in Switzerland

# Contents

	Page
Foreword.....	iv
<b>1 Scope</b> .....	<b>1</b>
<b>2 Normative references</b> .....	<b>1</b>
<b>3 Terms and definitions</b> .....	<b>1</b>
<b>4 Dimensions</b> .....	<b>2</b>
<b>5 Requirements and reference International Standards</b> .....	<b>3</b>
<b>6 Marking and labelling</b> .....	<b>5</b>
6.1 Marking on product.....	5
6.2 Labelling on package.....	5
<b>7 Designation</b> .....	<b>5</b>
<b>Annex A (normative) Nuts with <math>D &lt; M5</math> and <math>D &gt; M39</math>, not included in ISO 898-2</b> .....	<b>6</b>
<b>Bibliography</b> .....	<b>10</b>

## iTeh STANDARD PREVIEW (standards.iteh.ai)

[ISO/FDIS 4035](https://standards.iteh.ai/catalog/standards/sist/af656c8c-8102-4d89-9491-e67f2e2c985a/iso-fdis-4035)

<https://standards.iteh.ai/catalog/standards/sist/af656c8c-8102-4d89-9491-e67f2e2c985a/iso-fdis-4035>

## Foreword

ISO (the International Organization for Standardization) is a worldwide federation of national standards bodies (ISO member bodies). The work of preparing International Standards is normally carried out through ISO technical committees. Each member body interested in a subject for which a technical committee has been established has the right to be represented on that committee. International organizations, governmental and non-governmental, in liaison with ISO, also take part in the work. ISO collaborates closely with the International Electrotechnical Commission (IEC) on all matters of electrotechnical standardization.

The procedures used to develop this document and those intended for its further maintenance are described in the ISO/IEC Directives, Part 1. In particular the different approval criteria needed for the different types of ISO documents should be noted. This document was drafted in accordance with the editorial rules of the ISO/IEC Directives, Part 2 (see [www.iso.org/directives](http://www.iso.org/directives)).

Attention is drawn to the possibility that some of the elements of this document may be the subject of patent rights. ISO shall not be held responsible for identifying any or all such patent rights. Details of any patent rights identified during the development of the document will be in the Introduction and/or on the ISO list of patent declarations received (see [www.iso.org/patents](http://www.iso.org/patents)).

Any trade name used in this document is information given for the convenience of users and does not constitute an endorsement.

For an explanation on the meaning of ISO specific terms and expressions related to conformity assessment, as well as information about ISO's adherence to the WTO principles in the Technical Barriers to Trade (TBT) see the following URL: Foreword - Supplementary information

The committee responsible for this document is ISO/TC 2, *Fasteners*, Subcommittee SC 12, *Fasteners with metric internal thread*.

This fifth edition cancels and replaces the fourth edition (ISO 4035:2012).

The main changes compared to the previous edition are as follows:

- the use of thin nuts and a warning in relation to lower thread stripping resistance have been added in scope;
- nuts with  $D < M5$  and  $D > M39$  (not included in ISO 898-2) have been dealt with in normative [Annex A](#);
- M7 has been added;
- $d_{w,min}$  for sizes  $d \leq M5$  has been changed from  $s_{min} - IT16$  to  $s_{min} - IT15$  in order to have a larger bearing surface area and thus less contact pressure;
- $d_{a,max}$  and  $d_{w,min}$  have been specified with two decimal places;
- for steel nuts, quenching and tempering condition has been specified in accordance with ISO 898-2;
- for stainless-steel nuts, grades D4 and D6 and property classes 80 have been added;
- non-ferrous metal nuts have been cancelled (as a consequence of the cancellation of ISO 8839);
- specifications for marking and labelling have been added as [Clause 6](#).

Any feedback or questions on this document should be directed to the user's national standards body. A complete listing of these bodies can be found at [www.iso.org/members.html](http://www.iso.org/members.html).

# Fasteners — Hexagon thin nuts (style 0)

## 1 Scope

This document specifies the characteristics of hexagon thin nuts (style 0), in steel and stainless steel, with metric coarse pitch thread M1,6 to M64, and with product grades A and B.

Thin nuts used as jam nuts are to be assembled together with a regular or high nut.

**WARNING — Thin nuts (style 0) have a reduced loadability compared to regular nuts or high nuts, and are not designed to provide resistance to thread stripping (see ISO 898-2).**

If in certain cases other specifications are requested, stainless steel grades and property classes can be selected from ISO 3506-2.

## 2 Normative references

The following documents, in whole or in part, are normatively referenced in this document and are indispensable for its application. For dated references, only the edition cited applies. For undated references, the latest edition of the referenced document (including any amendments) applies.

ISO 225, *Fasteners — Bolts, screws, studs and nuts — Symbols and descriptions of dimensions*

ISO 898-2, *Fasteners — Mechanical properties of fasteners made of carbon steel and alloy steel — Part 2: Nuts with specified property classes*

ISO 965-1, *ISO general purpose metric screw threads — Tolerances — Part 1: Principles and basic data*

<https://standards.iteh.ai/catalog/standards/sist/af656c8c-8102-4d89-9491-e67f2e2c985a/iso-1891-4>, *Fasteners — Vocabulary — Part 4: Control, inspection, delivery, acceptance and quality*

ISO 3269, *Fasteners — Acceptance inspection*

ISO 3506-2, *Fasteners — Mechanical properties of corrosion-resistant stainless steel fasteners — Part 2: Nuts with specified grades and property classes*

ISO 4042, *Fasteners — Electroplated coating systems*

ISO 4759-1, *Tolerances for fasteners — Part 1: Bolts, screws, studs and nuts — Product grades A, B and C*

ISO 6157-2, *Fasteners — Surface discontinuities — Part 2: Nuts*

ISO 8991, *Designation system for fasteners*

ISO 8992, *Fasteners — General requirements for bolts, screws, studs and nuts*

ISO 10683, *Fasteners — Non-electrolytically applied zinc flake coating systems*

ISO 10684, *Fasteners — Hot dip galvanized coatings*

## 3 Terms and definitions

No terms and definitions are listed in this document.

ISO and IEC maintain terminological databases for use in standardization at the following addresses:

— ISO Online browsing platform: available at <https://www.iso.org/obp>

— IEC Electropedia: available at <https://www.electropedia.org/>

## 4 Dimensions

Dimensions for nuts with sizes M5 to M39 shall be in accordance with [Figure 1](#) and with [Tables 1](#) and [2](#). Dimensions for nuts with sizes  $D < M5$  and  $D > M39$  shall be in accordance with [Annex A](#).

Symbols and descriptions of dimensions are defined in ISO 225.

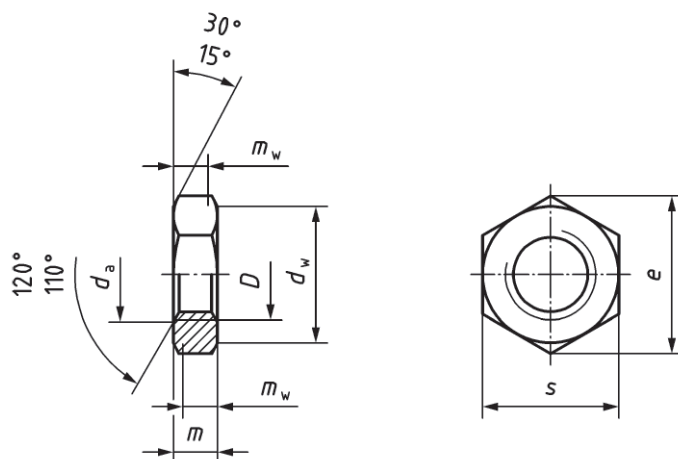

**Figure 1 — Nuts without washer-face**  
(standards.iteh.ai)

ISO/FDIS 4035

<https://standards.iteh.ai/catalog/standards/sist/af656c8c-8102-4d89-9491-e67f2e2c985a/iso-fdis-4035>

**Table 1 — Dimensions for nuts M5 to M18**

Dimensions in millimetres

Thread, $D$		<b>M5</b>	<b>M6</b>	(M7)	<b>M8</b>	<b>M10</b>	<b>M12</b>	(M14)	<b>M16</b>	(M18)
$p^a$		0,8	1	1	1,25	1,5	1,75	2	2	2,5
$d_a$	max.	5,75	6,75	7,75	8,75	10,80	12,96	15,12	17,28	19,44
	min.	5,00	6,00	7,00	8,00	10,00	12,00	14,00	16,00	18,00
$d_w$	min.	7,20	8,88	9,63	11,63	14,63	16,63	19,64	22,49	24,85
$e$	min.	8,79	11,05	12,12	14,38	17,77	20,03	23,36	26,75	29,56
$m$	max.	2,70	3,20	3,70	4,00	5,00	6,00	7,00	8,00	9,00
	min.	2,45	2,90	3,40	3,70	4,70	5,70	6,42	7,42	8,42
$m_w$	min.	1,96	2,32	2,72	2,96	3,76	4,56	5,14	5,94	6,74
$s$	nom. = max.	8,00	10,00	11,00	13,00	16,00	18,00	21,00	24,00	27,00
	min.	7,78	9,78	10,73	12,73	15,73	17,73	20,67	23,67	26,16

NOTE Sizes shown in brackets are non-preferred dimensions.

<sup>a</sup>  $P$  is the pitch of the thread.

**Table 2 — Dimensions for nuts M20 to M39**

Dimensions in millimetres

Thread, $D$		<b>M20</b>	(M22)	<b>M24</b>	(M27)	<b>M30</b>	(M33)	<b>M36</b>	(M39)
$p^a$		2,5	2,5	3	3	3,5	3,5	4	4
$d_a$	max.	21,60	23,76	25,92	29,16	32,40	35,64	38,88	42,12
	min.	20,00	22,00	24,00	27,00	30,00	33,00	36,00	39,00
$d_w$	min.	27,70	31,35	33,25	38,00	42,75	46,55	51,11	55,86
$e$	min.	32,95	37,29	39,55	45,20	50,85	55,37	60,79	66,44
$m$	max.	10,00	11,00	12,00	13,50	15,00	16,50	18,00	19,50
	min.	9,10	9,90	10,90	12,40	13,90	15,40	16,90	18,20
$m_w$	min.	7,28	7,92	8,72	9,92	11,12	12,32	13,52	14,56
$s$	nom. = max.	30,00	34,00	36,00	41,00	46,00	50,00	55,00	60,00
	min.	29,16	33,00	35,00	40,00	45,00	49,00	53,80	58,80

NOTE Sizes shown in brackets are non-preferred dimensions.

<sup>a</sup>  $P$  is the pitch of the thread.

## 5 Requirements and reference International Standards

The requirements specified in the International Standards referenced in [Table 3](#) shall apply. For nuts with  $D < M5$  and  $D > M39$ , [Annex A](#) shall apply.

**Table 3 — Requirements and reference International Standards**

Material		Steel	Stainless steel	
<b>General requirements</b>	International Standard	ISO 8992		
<b>Thread</b>	Tolerance class	6H <sup>a</sup>		
	International Standard	ISO 965-1		
<b>Mechanical properties</b>	Style	0		
	Property class and symbol	M5 ≤ D ≤ M39	04 <sup>b</sup> , 05 <sup>c</sup>	—
		D < M5 and D > M39	<a href="#">Annex A</a>	
	Grade <sup>d</sup> and property class and symbol	—	M5 ≤ D ≤ M24	A2-035, A4-035, A4-040, D4-040, D6-040
			M24 < D ≤ M39	A2-025, A2-035, A4-025, A4-035, D4-035, D6-035
			D < M5 and D > M39	<a href="#">Annex A</a>
International Standard	ISO 898-2	ISO 3506-2		
<b>Tolerances</b>	Product grade	D ≤ M16: A (except for M5 where $d_{w,min} = s_{min} - IT15$ ) D > M16: B		
	International Standard	ISO 4759-1		
<b>Finish - Coating</b>	As processed (no coating) Electroplated coatings as specified in ISO 4042 Non-electrolytically applied zinc flake coatings as specified in ISO 10683 Hot dip galvanized coatings as specified in ISO 10684	Clean and bright and/or Passivated <sup>e</sup>		
	Other finishes, coatings and/or additional requirements shall be agreed between the purchaser and the supplier			
<b>Surface integrity</b>	Limits for surface discontinuities as specified in ISO 6157-2	As agreed <sup>f</sup>		
<b>Acceptability</b>	Acceptance inspection as specified in ISO 3269			

<sup>a</sup> Depending on the type of coating to be applied, another tolerance position of the thread may be specified for the uncoated nuts in accordance with the relevant coating standard.

<sup>b</sup> Shall not be quenched and tempered in accordance with ISO 898-2 (NQT nuts).

<sup>c</sup> Shall be quenched and tempered in accordance with ISO 898-2 (QT nuts).

<sup>d</sup> The most common stainless steel grades are A2 and A4; however, depending on the application, it can be necessary to select other grades in ISO 3506-2 suitable for the service corrosive environment. For use at high temperatures (up to 800 °C), mechanical properties are specified in ISO/FDIS 3506-5. See also ISO 3506-6 for the selection of suitable stainless steel grades.

<sup>e</sup> See e.g. ISO 16048.

<sup>f</sup> See e.g. ISO 6157-2.



## 6 Marking and labelling

### 6.1 Marking on product

Marking shall be:

- for steel nuts, as specified in ISO 898-2,
- for stainless steel nuts, as specified in ISO 3506-2.

### 6.2 Labelling on package

Labelling on the package shall be in accordance with ISO 898-2 or ISO 3506-2, and shall include at least:

- the reference to this document, i.e. ISO 4035,
- the thread size *D*,
- for steel nuts, the symbol of the property class,
- for stainless steel nuts, the grade and symbol of the property class,
- the type of "Finish – Coating",
- the manufacturer's and/or distributor's identification and/or name,
- the manufacturing lot number as specified in ISO 1891-4,
- the quantity of pieces in the package.

## 7 Designation

The designation requirements as specified in ISO 8991 shall apply with:

- for steel nuts, the symbol of the property class as specified in ISO 898-2,
- for stainless steel nuts, the grade and symbol of the property class as specified in ISO 3506-2.

When no specific "Finish – Coating" is specified in the designation, fasteners are delivered in the "as processed" condition and stainless steel fasteners in the "clean and bright" condition.

**EXAMPLE** A hexagon thin nut (style 0) in accordance with this document, with thread size M12, product grade A, property class 05, as processed, is designated as follows:

**Hexagon thin nut ISO 4035 – M12 – 05**

## Annex A (normative)

### Nuts with $D < M5$ and $D > M39$ , not included in ISO 898-2

#### A.1 Design of hexagon thin nuts (style 0)

Hexagon thin nuts (style 0) have been designed in accordance with the following:

- thin nuts with  $M1,6 \leq D \leq M64$  have a minimum height  $m_{\min} \geq 0,45D$ , in accordance with ISO 898-2;
- thin nuts with  $M1,6 \leq D < M64$  have a maximum height  $m_{\max} \geq 0,5D$ ;
- mechanical properties are not included in ISO 898-2 for nuts with  $D < M5$  and  $D > M39$ , they are specified in this [Annex A](#).

#### A.2 Dimensions

Dimensions shall be in accordance with [Figure 1](#) and with [Tables A.1](#) and [A.2](#).

iTeh STANDARD PREVIEW  
(standards.iteh.ai)

[ISO/FDIS 4035](#)

<https://standards.iteh.ai/catalog/standards/sist/af656c8c-8102-4d89-9491-e67f2e2c985a/iso-fdis-4035>