



Designation: D7569 – 10

Standard Practice for Determination of Gas Content of Coal—Direct Desorption Method¹

This standard is issued under the fixed designation D7569; the number immediately following the designation indicates the year of original adoption or, in the case of revision, the year of last revision. A number in parentheses indicates the year of last reapproval. A superscript epsilon (ϵ) indicates an editorial change since the last revision or reapproval.

1. Scope

1.1 This practice describes methods for the direct determination of the gas content of coal by desorption using samples obtained by drill coring methods from the surface. It sets out guidelines for the equipment construction, sample preparation and testing procedure, and method of calculation.

1.2 Indirect methods for the determination of the gas content of coal (not covered in this practice) are based on either the gas absorption characteristics of coal under a given pressure and temperature condition or other empirical data that relate the gas content of coal to such other parameters as coal rank, depth of cover, or gas emission rate.

1.3 This practice covers the following two direct methods, which vary only in the time allowed for the gas to desorb from the core, or sidewall core, before final crushing:

1.3.1 The slow desorption method in which volumetric readings of gas content are taken frequently (for example, every 10 to 15 min) during the first few hours, followed by hourly measurements for several hours, and then measurements on 24-h intervals until no or very little gas is being desorbed for an extended period of time.

1.3.2 The fast desorption method in which after initial desorbed gas measurements to obtain data for lost gas calculations, the canister is opened and the sample is transferred to the coal crusher. The remaining gas volume is measured on a crushed sample.

1.4 This practice is confined to the direct method using core, or sidewall core obtained from drilling. The practice can be applied to drill cuttings samples; however, the use of cuttings is not recommended because the results may be misleading and are difficult to compare to the results obtained from core desorption. The interpretation of the results does not fall within the scope of the practice.

1.5 *Units*—The values stated in either SI units or inch-pound units are to be regarded separately as the standard. The

values stated in each system may not be exact equivalents; therefore, each system shall be used independently of the other. Combining values from the two systems may result in nonconformance with the standard.

1.6 *This standard does not purport to address all of the safety concerns, if any, associated with its use. It is the responsibility of the user of this standard to establish appropriate safety and health practices and determine the applicability of regulatory limitations prior to use.*

2. Referenced Documents

2.1 ASTM Standards:²

- D121 Terminology of Coal and Coke
- D167 Test Method for Apparent and True Specific Gravity and Porosity of Lump Coke
- D1412 Test Method for Equilibrium Moisture of Coal at 96 to 97 Percent Relative Humidity and 30°C
- D2799 Test Method for Microscopical Determination of the Maceral Composition of Coal
- D3172 Practice for Proximate Analysis of Coal and Coke
- D3173 Test Method for Moisture in the Analysis Sample of Coal and Coke
- D3174 Test Method for Ash in the Analysis Sample of Coal and Coke from Coal
- D3176 Practice for Ultimate Analysis of Coal and Coke
- D3180 Practice for Calculating Coal and Coke Analyses from As-Determined to Different Bases
- D3302 Test Method for Total Moisture in Coal
- D5192 Practice for Collection of Coal Samples from Core
- E1272 Specification for Laboratory Glass Graduated Cylinders

2.2 Australian Standard:

- AS 3980 Guide to the determination of gas content of coal—Direct desorption method³

¹ This practice is under the jurisdiction of ASTM Committee D05 on Coal and Coke and is the direct responsibility of Subcommittee D05.21 on Methods of Analysis.

Current edition approved Sept. 1, 2010. Published October 2010. DOI: 10.1520/D7569-10.

² For referenced ASTM standards, visit the ASTM website, www.astm.org, or contact ASTM Customer Service at service@astm.org. For *Annual Book of ASTM Standards* volume information, refer to the standard's Document Summary page on the ASTM website.

³ Available from Standards Australia Limited, 286 Sussex St., Sydney, NSW, 2000, Australia, GPO Box 476, Sydney, NSW, 2001 Australia or via the website: www.standards.org.au.

2.3 ISO Standard:

ISO 6706 Plastics laboratory ware—Graduated measuring cylinders⁴

2.4 DIN Standard:

DIN 12681 Plastics laboratory ware—Graduated measuring cylinders⁵

3. Terminology

3.1 Definitions:

3.1.1 For additional definitions of terms used in this practice, refer to Terminology **D121**.

3.1.2 *absolute permeability, n*—permeability of a rock to a particular fluid when the rock is 100 % saturated with the flowing fluid. **(1)**⁶

3.1.3 *absorbed gas, n*—gas that is molecularly dissolved within a liquid phase or has penetrated into the lattice structure of a solid. **(1)**

3.1.4 *actual lost gas time, n*—lost gas time determined from the time at which the sample being recovered reaches a depth where the hydrostatic pressure of the drilling fluid column equals the original (immediately before sampling) reservoir pressure in the sample to the time at which the sample is sealed in a desorption canister.

3.1.4.1 *Discussion*—Essentially, the actual lost gas time is the amount of time between when the core starts its trip to the surface and it is sealed in the canister. **(1)**

3.1.5 *adsorption, n*—attachment, through physical or chemical bonding, of fluid phase molecules to an interfacial surface.

3.1.5.1 *Discussion*—The adsorbed phase molecules are sequestered at the interfacial surface in a metastable equilibrium state, the stability of which is strongly affected by changes in temperature and pressure. **(1)**

3.1.6 *adsorption isotherm, n*—quantitative relationship, at constant temperature, describing how the concentration of adsorbed phase molecules at an interfacial surface varies as a function of increasing system pressure. **(1)**

3.1.7 *as-received basis, n*—analytical data calculated to the moisture condition of the sample as it arrived at the laboratory and before any processing or conditioning.

3.1.7.1 *Discussion*—If the sample has been maintained in a sealed state so that there has been no gain or loss, the as-received basis is equivalent to the moisture basis as sampled. **(D3180, D5192, D1412, D3302)**

3.1.8 *canister, n*—container that can be sealed into which a coal sample is placed to allow desorption to occur.

3.1.8.1 *Discussion*—The reduction in pressure to atmospheric pressure (at surface) causes the sample to release gas into the canister. By measuring the amount of gas released and the weight of the sample, the gas content can be determined.

Gas content is conventionally reported in units of cubic centimetres/gram (cm³/g), cubic metres/tonne (m³/ton), or standard cubic feet/ton (scf/ton). **(1)**

3.1.9 *continuous coring, v*—refers to continuous coring with wireline recovery. **(1)**

3.1.10 *conventional core, n*—“large” diameter core (8.9 cm or 3.5 in. diameter or larger) in which the core barrel is recovered to the surface after drilling a fixed interval by pulling the drill string. **(1)**

3.1.11 *core, n—in drilling*, a cylindrical section of rock (coal) that is usually 5 to 10 cm in diameter taken as part of the interval penetrated by a core bit and brought to the surface for geologic examination, representative sampling, and laboratory analyses. **(D121, D5192)**

3.1.12 *cuttings, n—in drilling*, rock fragments that break away because of the action of the drill bit and are transported to the surface by the drilling circulation system (mud or air).

3.1.12.1 *Discussion*—Cuttings may be screened and collected from the circulation medium for lithologic characterization or analytical tests. **(2)**

3.1.13 *delivery tube, n*—flexible tube connecting a desorption canister to a volumetric displacement apparatus. **(1)**

3.1.14 *desorption, n*—detachment of adsorbed molecules from an interfacial surface (see *adsorption*). **(1)**

3.1.15 *desorption data analysis software, n*—software used for analyzing desorption data. **(1)**

3.1.16 *desorption rate, n*—volumetric rate at which gas desorbs from a sample. **(1)**

3.1.17 *diffusion, n*—process whereby particles of liquids or gases move from a region of higher to lower concentration independent of the pressure gradient. **(1)**

3.1.18 *diffusivity, n*—ratio of the diffusion coefficient to the square of a typical diffusion distance. **(1)**

3.1.19 *direct desorption method, n*—method for representing desorption of gas from coal or other materials in which gas storage as a result of adsorption is significant.

3.1.19.1 *Discussion*—It mathematically presumes constant temperature diffusion from a sphere initially at uniform gas concentration. The solution of the basic equation adopted suggests that the measured desorbed gas volume is proportional to the square root of time since the start of desorption (time zero). The direct method is the most widely used method for estimating lost gas volume. **(1)**

3.1.20 *dry, ash-free basis, n*—data calculated to a theoretical base of no moisture or ash associated with the sample.

3.1.20.1 *Discussion*—Numerical values as established by Test Methods **D3173** and **D3174** are used for converting the as-determined data to a moisture- and ash-free basis. **(D3180)**

3.1.21 *fast desorption method, n*—after initial measurements to obtain the basis for lost gas calculations, the canister is opened and the sample is transferred to a coal-crushing device that is modified so that the remaining desorbed gas volume from the crushed coal sample can be measured.

(AS 3980)

⁴ Available from the International Organization for Standardization (ISO), 1, rue de Varembe, Case Postale 56, CH-1211 Geneva 20, Switzerland or via the website: <http://www.iso.org/>.

⁵ Available from Deutsches Institut für Normung e. V., 10772 Berlin or via the website: <http://www2.din.de>.

⁶ The boldface numbers in parentheses refer to the list of references at the end of this standard.

3.1.22 *free gas, n*—unabsorbed gas within the pores and natural fractures. (1)

3.1.23 *gas-in-place, n*—amount of gas present in a seam or an interval of discrete thickness or in multiple seams or intervals determined from the gas content, bulk density, thickness, and drainage area.

3.1.23.1 *Discussion*—Estimates of gas-in-place usually reflect total gas content, which in addition to methane, may include others gases such as carbon dioxide or nitrogen. (1)

3.1.24 *gas saturated, adv*—state in which the gas content (determined from direct or indirect desorption measurements) is equal to the gas storage capacity (determined from isotherms). (1)

3.1.25 *gas storage capacity, n*—maximum amount of gas or gas mixtures (normalized according to the relevant basis) that can be held by a sample at various reservoir pressures, reservoir temperature, and a specific moisture (water) content. (1)

3.1.26 *head space volume, n*—void space in a canister containing a sample.

3.1.26.1 *Discussion*—Canister desorption measurements are corrected for the effect of expansion or contraction of gases in the canister head space in response to temperature and pressure fluctuations. (1)

3.1.27 *indirect method for the determination of the gas content of coal, n*—method based on either the gas absorption characteristics of coal under a given pressure and temperature condition or other empirical data that relate the gas content of coal to such other parameters as coal rank, depth of cover, or gas emission rate.

3.1.28 *in-situ basis, adj*—a basis in which gas content is determined from a plot of gas content versus bulk density (determined from open-hole high-resolution bulk density log data). (1)

3.1.29 *isotherm (sorption isotherm), n*—quantitative relationship, at constant temperature, that describes how the concentration of adsorbed phase molecules at an interfacial surface varies as a function of system pressure. (1)

3.1.30 *lost gas time, n*—time between when the sample gas pressure falls below the reservoir pressure during sample recovery (time zero) and the time when the sample is sealed in a desorption canister. (1)

3.1.31 *lost gas volume, n*—volume of gas that is released from a sample (generally under conditions of decreasing temperature and pressure) before it can be placed in a canister and measured (between the time when the sample gas pressure falls below the reservoir pressure during sample recovery and the time when the sample is sealed in a desorption canister). (1)

3.1.32 *macropore, n*—pores in the coal larger than 50 nm. (3)

3.1.33 *manometer, n*—see *volumetric displacement apparatus*.

3.1.34 *measured gas volume, n*—measured volume of gas that is released from a sample into a desorption canister, reported at standard temperature and pressure conditions. (1)

3.1.35 *mesopores, n*—pores in the coal larger than 2 nm and less than 50 nm. (3)

3.1.36 *micropores, n*—pores with a width of less than 2 nm. (3)

3.1.37 *modified direct method, n*—modification of the direct method by the U.S. Bureau of Mines according to Diamond and Levine (4) and Diamond and Schatzel (5) to account precisely for changes in the concentration of gaseous species during desorption, with particular applications to situations in which small amounts of gas are evolved. (1)

3.1.38 *quick connect fittings, n*—pipe fittings designed for easy and rapid connection and disconnection.

3.1.39 *raw basis, n*—basis for gas content calculation whereby the gas volume is divided by the actual sample weight regardless of the moisture content or the presence of non-coal in the canister sample. (1)

3.1.40 *residual gas volume, n*—volume of the total sorbed gas that remains in the sample after desorption into a canister has effectively ceased (after termination of canister desorption).

3.1.40.1 *Discussion*—Residual gas volume, as defined and reported, can be very different for slow desorption and fast desorption methods. Early termination of desorption followed by sample crushing will obviously lower desorbed quantities of gas and increase the residual values. Maceral composition, lithotype composition, and the coal bench being sampled may all affect permeability on small-scale samples. (1)

3.1.41 *sidewall core, n*—small diameter core taken down-hole by wireline methods using percussion or mechanical methods to drill into the side of the borehole.

3.1.41.1 *Discussion*—The percussion method cores by explosively firing hollow core barrels into a coal seam and then retrieving the coal plug to the surface. The mechanical method uses hollow rotary drills to core into the coal seam and then pull the core plugs back into the tool and then they are retrieved.

3.1.42 *slow desorption method, n*—volumetric readings of canister gas content are taken frequently (for example, every 10 to 15 min) during the first few hours, followed by hourly measurements for several hours, and then measurements on 24-h intervals until no or very little gas is being desorbed for an extended period of time.

3.1.42.1 *Discussion*—Some coals can desorb in excess of one year and a desorption base line may be established with measured gas volumes consistently below 10 cm³ per reading. At this slow desorption rate, no gas is expected to be lost when transferring the sample from the desorption canister to the residual gas canister.

3.1.42.2 *Discussion*—If the measured gas volume of a canister falls at or below 10 cm³ per reading (where measurement error becomes too great), then that canister may be elevated to the next time measurement period. This procedure is continued until measured gas volumes are consistently below 10 cm³ per reading. (AS 3980, (6))

3.1.43 *sorbed gas, n*—coalbed gas retained by adsorption or absorption processes or both. (1)

3.1.44 *sorption time, n*—time required for 63.2 % of the total sorbed gas (including residual gas) to be released.

3.1.44.1 *Discussion*—It is reported in either hours or days (since time zero) depending on the relative rate at which gas is released from a desorption sample. (1)

3.1.45 *sorption standard temperature and pressure conditions (STP), n*—various standards exist.

3.1.45.1 *Discussion*—Historically, the petroleum industry almost universally has used Imperial units of 60°F (15.56°C or 288.6K) as the reference temperature and 14.7 psia (101.3 kPa) as the reference pressure. See Ref 7. SI systems have used 0, 20, and 25°C (32, 68, and 77°F) most commonly, depending on the data and the area of specialty. The American Petroleum Institute (API, see Ref 8) has opted for 15°C (59°F) because it is close to 60°F (15.56°C). The Society of Petroleum Engineers (Refs 9 and 10) suggests that the choice between 0 and 15°C (32 and 59°F) is arbitrary. Government gas reserve reporting regulations may mandate which system to use, Imperial or SI (metric) (Ref 10). For coal gas desorption purposes, a standard of 15°C has been adopted simply to conform to API standards. It may be desirable to have a flexible temperature standard for various applications. (1)

3.1.46 *time zero, n*—time at which a sample falls below the reservoir or desorption pressure during sample recovery.

3.1.46.1 *Discussion*—Time zero is generally marked when the sample lifts off the bottom of the hole. However, more study of the sample retrieval process is required to determine better the depth that the sample desorption process actually begins. (1)

3.1.47 *total gas volume, n*—sum of lost gas, measured gas, and residual gas volumes (all measured on the same sample volume). (1)

3.1.48 *U.S. Bureau of Mines (USBM) lost gas time, n*—lost gas time determined from time zero, where time zero is defined as the time when the sample reaches a depth halfway to the surface. (1)

3.1.49 *volumetric displacement apparatus (manometer), n*—device, maintained at ambient conditions, for measuring the amount of gas desorbed into a canister. (1)

4. Summary of Practice

4.1 This practice describes standardized guidelines for the determination of the gas content of coal by desorption using samples obtained by drill coring methods.

4.2 Immediately after the coal core sample reaches the surface and after the depth of the sample, state of the core, and proportion of coal to non-coal material are recorded, the sample is transferred into a canister and the canister is sealed. Multiple samples from a coal bed should be collected to obtain a gas content representative of the whole coal bed.

4.3 Desorbed gas content (in cubic centimetres) can be measured using a volume displacement apparatus by the slow or fast desorption method, or a combination of the two methods, depending primarily upon the urgency of having gas content data. In the slow desorption method, gas measurements are continued until measured gas volumes are consistently

below 10 cm³ per reading, which for some coals may take more than a year's time to desorb to this level. In the fast desorption method, when sufficient measurements are made to obtain data for lost gas calculations (usually more than 4 h of frequent measurements), the canister is opened and the sample is transferred to the coal crusher. The remaining gas volume is measured on a crushed sample. For gas composition or gas isotope analyses or both, the gas is sampled during desorption.

4.4 All data are entered and maintained on predesigned data forms and spreadsheets. Lost gas, desorbed gas, and residual gas contents are added to obtain total gas content that, after recalculation on sample weigh basis, yields total gas content expressed in cm³/g, m³/ton (SI units), or scf/ton (Imperial units).

5. Significance and Use

5.1 Canister desorption is a widely used technique to measure the gas content of coal. The gas content data when normalized to volume/weight and multiplied by coal mass is used to estimate the gas in place in an area around the cored well.

6. Apparatus

6.1 *Background*—In desorption studies of methane content in coal beds, the goal is to capture quickly the coal sample in a pressure-tight container purged of the air-bearing headspace gas using an inert gas or water to stabilize the sample. Towards this goal, a container (canister) shall be designed and constructed/fabricated for core that would be easy to handle, fill, and close rapidly forming a reliably gastight seal, and facilitate rapid desorbing gas measurements. The primary coal core desorption equipment consists of desorption canisters made of sealed aluminum or plastic and a volumetric displacement apparatus or manometer; these items can be purchased from suppliers that use custom designs (1, 11) (Fig. 1) or locally constructed with off-the-shelf materials and parts (12-14) (Fig. 2).

6.2 *Materials and Construction of Desorption Canisters*—Canister materials in widespread use today are aluminum, plastic-coated aluminum, and plastic, usually polyvinyl chloride (PVC) materials. The use of stainless steel, although advantageous because of its inert qualities, is not in widespread use because of the high cost of materials and labor. The use of canisters made of unsealed aluminum is not recommended in this practice because of the potential for significant reaction with coal gases and related formation or drilling fluids after the canister is closed. In general, all components of the desorption canister should be made of, or treated to be, nonreactive with regard to the coal or the normally low pH fluids associated with the coal and hydrogen sulfide (H₂S) or other corrosive gases that may evolve during desorption. The canisters should be made leak-proof by using a sealing device or cap such as a neoprene and plastic plug held in place by a wing nut or clamp, a threaded PVC plug sealed by an O-ring, or a coated aluminum cap sealed with a neoprene gasket. One end of the canister should have a permanent cap glued in place (Fig. 2). To prevent leaks, the removable cap area shall be cleaned of coal particles after the coal sample is placed in the canister and

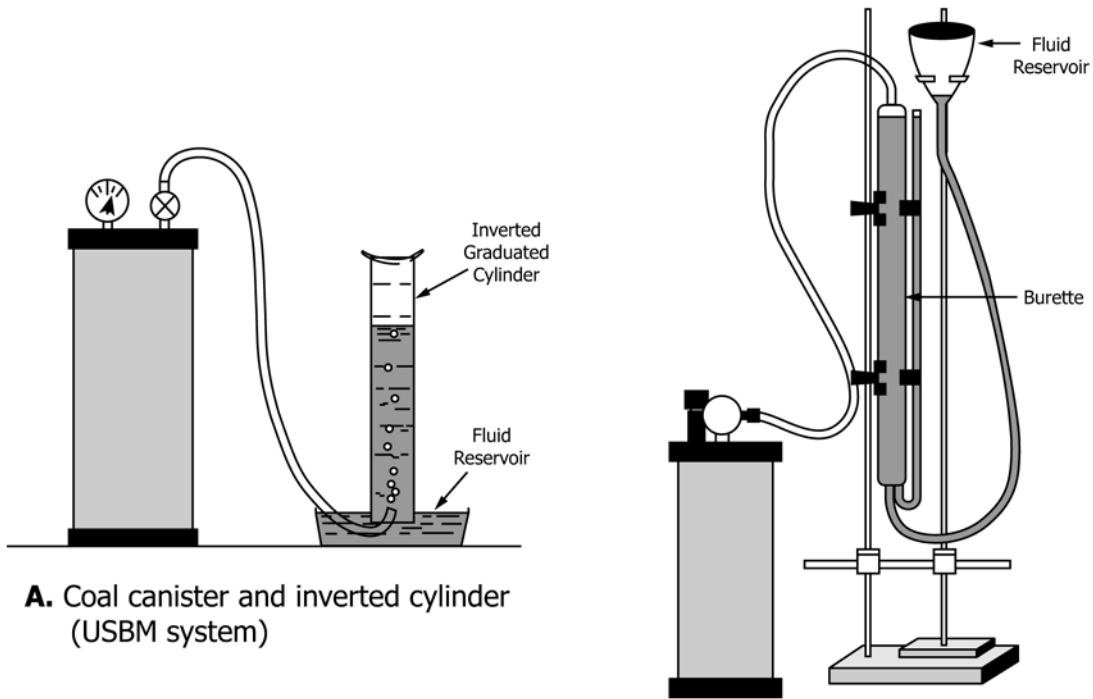

A. Coal canister and inverted cylinder (USBM system)

B. Improved design for volumetric measurement system

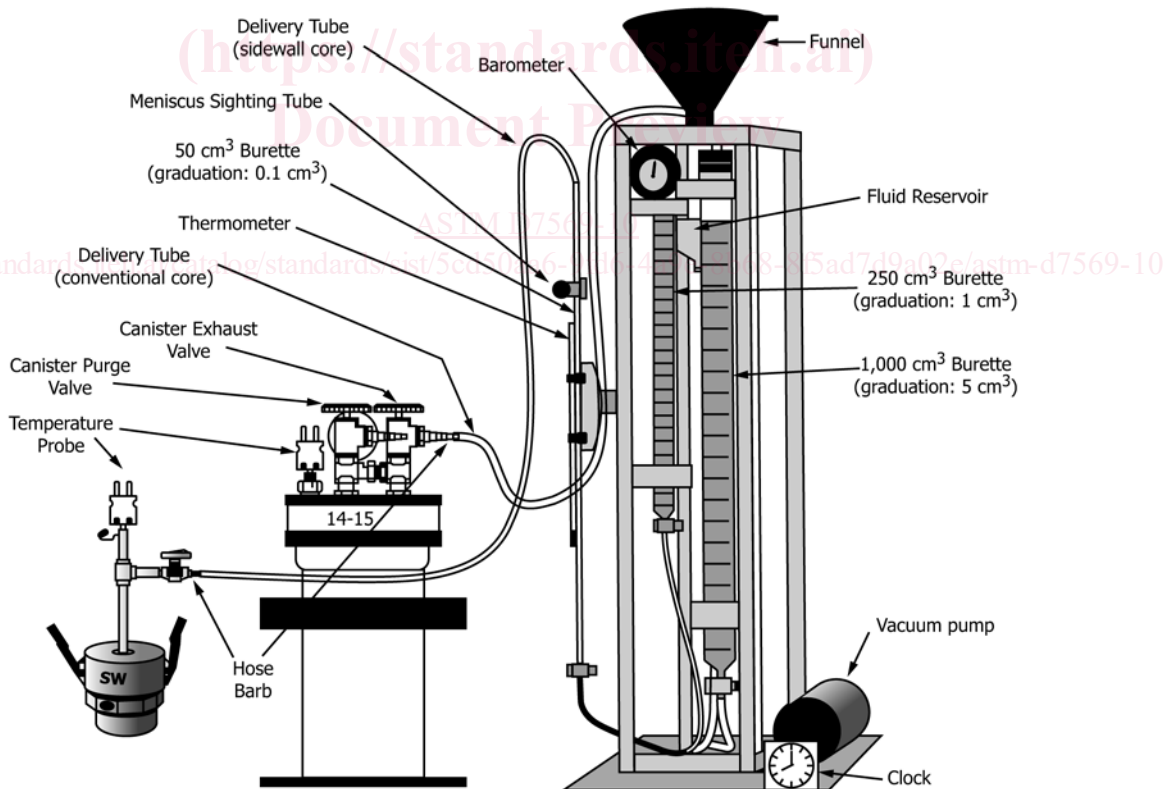

C. Typical industry design for sidewall and core canisters, and volumetric displacement apparatus

FIG. 1 Progressive Development of Canister and Volumetric Displacement Apparatus Design (Courtesy of Gas Technology Institute [see Refs 1, 4, and 10])

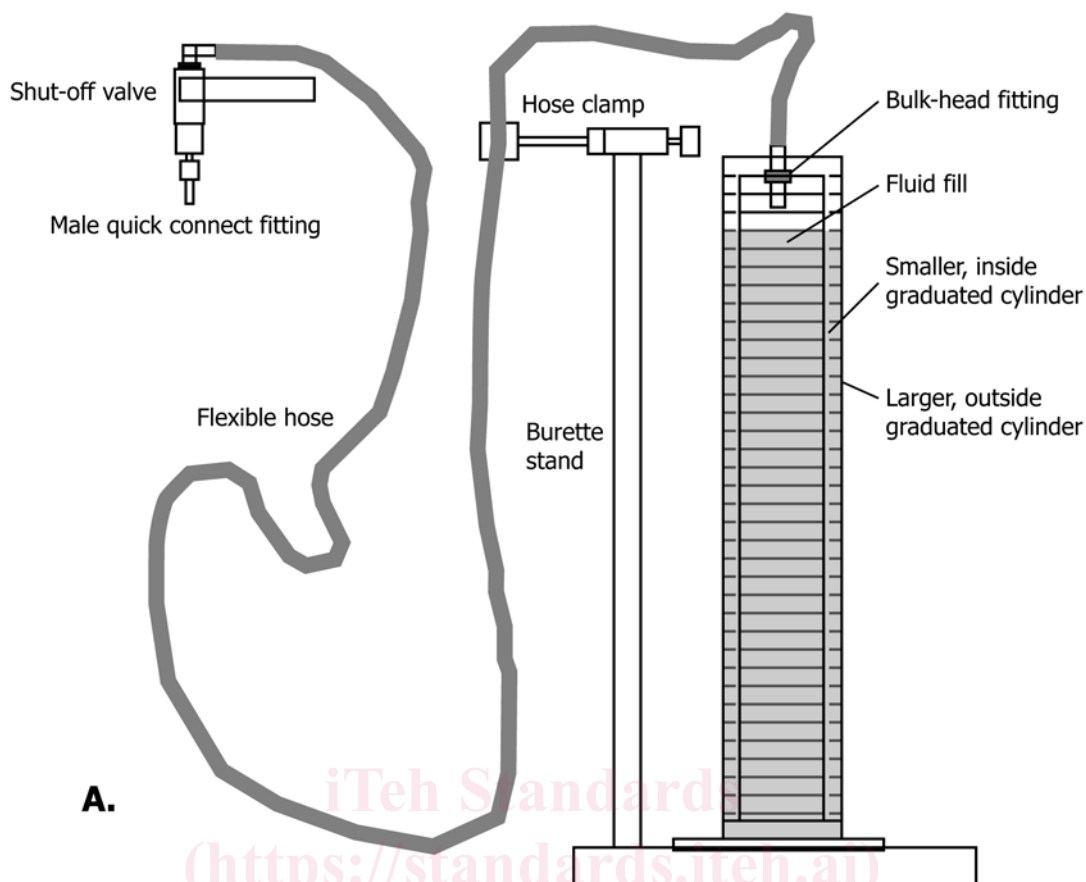

A.

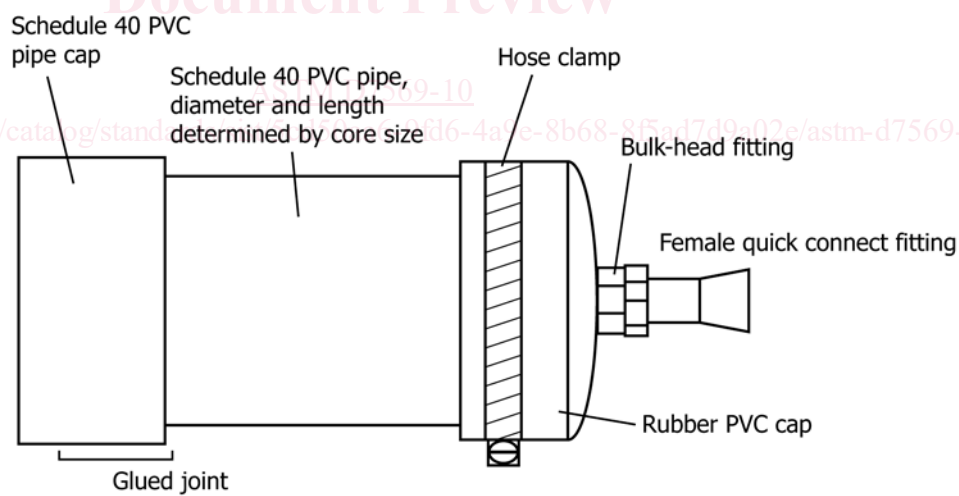

B.

FIG. 2 Custom-Made (A) Volumetric Displacement Apparatus and (B) Canister Constructed from Off-the Shelf Materials (see Refs 12 and 13)

before the canister is closed. The use of PVC for gas desorption canisters was first done in the 1980s by the USBM (5, 15).

6.3 *Equipment for Making Measurements*—During desorption, the closed canister is periodically connected via a hose and quick-connect system to a volumetric displacement apparatus (manometer) to measure the desorbed volume of gas. At the time of measurement, the barometric pressure (P) and

ambient temperature (T) in the volumetric displacement apparatus are recorded. National Institute of Standards and Technology (NIST) traceable calibrated digital barometers and thermometers are recommended for these P and T measurements. If the canister headspace is not filled with water to make its volume zero, then it is necessary to measure headspace gas temperature to correct for expansion or contraction of the