



SLOVENSKI STANDARD
SIST EN 16228-3:2014+A1:2022

01-marec-2022

Oprema za vrtanje in temeljenje - Varnost - 3. del: Oprema za vodoravno usmerjeno vrtanje (HDD) (vključno z dopnilom A1)

Drilling and foundation equipment - Safety - Part 3: Horizontal directional drilling equipment (HDD)

Geräte für Bohr- und Gründungsarbeiten - Sicherheit - Teil 3: Geräte für das gerichtete Horizontalbohrverfahren (HDD)

Machines de forage et de fondation - Sécurité - Partie 3 : Machines de forage horizontal dirigé (HDD)

Ta slovenski standard je istoveten z: EN 16228-3:2014+A1:2021

<https://standards.iteh.ai/catalog/standards/sist/1c261ded-5755-4955-9679-0ac5df8f648a/sist-en-16228-3-2014a1-2022>

ICS:

25.080.40	Vrtalniki	Drilling machines
53.100	Stroji za zemeljska dela	Earth-moving machinery
93.020	Zemeljska dela. Izkopavanja. Gradnja temeljev. Dela pod zemljo	Earthworks. Excavations. Foundation construction. Underground works

SIST EN 16228-3:2014+A1:2022

en,fr,de

**iTeh STANDARD
PREVIEW
(standards.iteh.ai)**

SIST EN 16228-3:2014+A1:2022

<https://standards.iteh.ai/catalog/standards/sist/fc261dcd-5755-4955-9679-0ac5df8f648a/sist-en-16228-3-2014a1-2022>

EUROPEAN STANDARD

EN 16228-3:2014+A1

NORME EUROPÉENNE

EUROPÄISCHE NORM

December 2021

ICS 93.020

Supersedes EN 16228-3:2014

English Version

Drilling and foundation equipment - Safety - Part 3: Horizontal directional drilling equipment (HDD)

Machines de forage et de fondation - Sécurité - Partie 3
: Machines de forage horizontal dirigé (HDD)

Geräte für Bohr- und Gründungsarbeiten - Sicherheit -
Teil 3: Geräte für das gerichtete
Horizontalbohrverfahren (HDD)

This European Standard was approved by CEN on 6 March 2014 and includes Amendment 1 approved by CEN on 22 November 2021.

CEN members are bound to comply with the CEN/CENELEC Internal Regulations which stipulate the conditions for giving this European Standard the status of a national standard without any alteration. Up-to-date lists and bibliographical references concerning such national standards may be obtained on application to the CEN-CENELEC Management Centre or to any CEN member.

This European Standard exists in three official versions (English, French, German). A version in any other language made by translation under the responsibility of a CEN member into its own language and notified to the CEN-CENELEC Management Centre has the same status as the official versions.

CEN members are the national standards bodies of Austria, Belgium, Bulgaria, Croatia, Cyprus, Czech Republic, Denmark, Estonia, Finland, France, Germany, Greece, Hungary, Iceland, Ireland, Italy, Latvia, Lithuania, Luxembourg, Malta, Netherlands, Norway, Poland, Portugal, Republic of North Macedonia, Romania, Serbia, Slovakia, Slovenia, Spain, Sweden, Switzerland, Turkey and United Kingdom.

<https://standards.iteh.ai/catalog/standards/sist/fc261dcd-5755-4955-9679-0ac5df8f648a/sist-en-16228-3-2014a1-2022>



EUROPEAN COMMITTEE FOR STANDARDIZATION
COMITÉ EUROPÉEN DE NORMALISATION
EUROPÄISCHES KOMITEE FÜR NORMUNG

CEN-CENELEC Management Centre: Rue de la Science 23, B-1040 Brussels

Contents	Page
European foreword.....	4
Introduction	6
1 Scope.....	7
2 Normative references.....	7
3 Terms and definitions	8
4 List of additional significant hazards.....	10
5 Safety requirements and/or protective measures	11
5.1 General.....	11
5.2 Stability.....	11
5.2.1 General.....	11
5.2.2 Ground pressure.....	11
5.3 Brakes.....	12
5.3.1 Brakes for travelling.....	12
5.3.2 Brakes for slewing.....	12
5.4 Winches, draw-works and ropes.....	12
5.4.1 General.....	12
5.4.2 Roller and leaf chains	12
5.5 Indicating devices for inclination.....	12
5.6 Operating position(s)	12
5.6.1 General.....	12
5.6.2 Cab/Cabin.....	12
5.6.3 Driving, tramming and operating(s) position	13
5.6.4 Falling Object Protection (FOPS).....	13
5.7 Access to operating positions, intervention and servicing points	13
5.8 Retrieval, transportation, lifting and towing of horizontal directional drills and their parts.....	13
5.9 Travel speed.....	13
5.10 Control devices.....	13
5.10.1 General.....	13
5.10.2 Pedestrian controlled horizontal directional drills	14
5.10.3 Protective measures for stopping of rotation and feed.....	14
5.11 Equipment for information and warning.....	14
5.11.1 General.....	14
5.11.2 Warning devices	14
5.12 Guards and protective devices	14
5.12.1 General.....	14
5.12.2 Design.....	14
5.12.3 Foot barrier	15
5.12.4 Danger zones at rear of machine.....	15
5.12.5 Elevating drill frame	15
5.12.6 Breakout clamps.....	15
5.12.7 Ground fixation device.....	15
5.12.8 Horizontal directional drills with a drill rod/pipe storage magazine	15
5.12.9 Horizontal directional drills without a mechanical drill/pipe handling system.....	16
5.12.10 Ⓐ Restricted operating mode Ⓐ	16

5.13	Immobilisation system	16
5.14	Drill frame extensions	17
5.15	A1 Noise A1	17
6	Verification of the safety requirements and/or protective measures	17
6.1	General	17
6.2	Fitness for purpose testing.....	20
7	Information for use.....	20
7.1	General	20
7.2	Operator's manual.....	20
7.3	Warning signs	21
Annex A (informative) Symbols and signs		22
A.1	General	22
A.2	Symbols for base machine and drilling rack.....	22
A.3	Symbols for front vice	23
A.4	Symbols for rod cradle.....	24
A.5	Symbols for drill head.....	25
A.6	Symbols for earth anchor.....	26
A.7	Symbols for rod clamp	27
A.8	Symbols for rod loader	29
A.9	Symbols for Drilling Fluid Supply.....	31
Annex B (normative) Noise test code		35
B.1	General	35
B.2	Operating conditions.....	35
Annex ZA (informative) A1 Relationship between this European Standard and the essential requirements of Directive 2006/42/EC aimed to be covered A1		36
Bibliography		40

EN 16228-3:2014+A1:2021 (E)

European foreword

This document (EN 16228-3:2014+A1:2021) has been prepared by Technical Committee CEN/TC 151 “Construction equipment and building material machines - Safety”, the secretariat of which is held by DIN.

This European Standard shall be given the status of a national standard, either by publication of an identical text or by endorsement, at the latest by June 2022 and conflicting national standards shall be withdrawn at the latest by June 2022.

Attention is drawn to the possibility that some of the elements of this document may be the subject of patent rights. CEN shall not be held responsible for identifying any or all such patent rights.

This document supersedes A1 EN 16228-3:2014 A1.

This document includes Amendment 1 approved by CEN on 22 November 2021.

The start and finish of text introduced or altered by amendment is indicated in the text by tags A1 A1.

This document has been prepared under a Standardization Request given to CEN by the European Commission and the European Free Trade Association, and supports essential requirements of EU Directive(s) / Regulation(s).

For relationship with EU Directive(s) / Regulation(s), see informative Annex ZA, which is an integral part of this document.

This European Standard is divided into several parts and covers drilling and foundation equipment.

Part 1 contains requirements that are/may be common to all drilling and foundation equipment. Other parts contain additional requirements for specific machines that supplement or modify the requirements of part 1. Compliance with the clauses of part 1 together with those of a relevant specific part of this standard giving requirements for a particular machine provides one means of conforming with the essential health and safety requirements of the Directive concerned.

When a relevant specific part does not exist, part 1 can help to establish the requirements for the machine, but will not by itself provide a means of conforming to the relevant essential health and safety requirements of the Directive.

This European Standard, EN 16228, *Drilling and foundation equipment – Safety*, consists of the following parts:

- *Part 1: Common requirements*
- A1 *Part 2: Mobile drill rigs for civil and geotechnical engineering in soil or soil and rock mixture* A1
- *Part 3: Horizontal directional drilling equipment (HDD)*
- *Part 4: Foundation equipment*
- *Part 5: Diaphragm walling equipment*
- *Part 6: Jetting, grouting and injection equipment*

— *Part 7: Interchangeable auxiliary equipment*

Any feedback and questions on this document should be directed to the users' national standards body. A complete listing of these bodies can be found on the CEN website.

According to the CEN-CENELEC Internal Regulations, the national standards organisations of the following countries are bound to implement this European Standard: Austria, Belgium, Bulgaria, Croatia, Cyprus, Czech Republic, Denmark, Estonia, Finland, France, Germany, Greece, Hungary, Iceland, Ireland, Italy, Latvia, Lithuania, Luxembourg, Malta, Netherlands, Norway, Poland, Portugal, Republic of North Macedonia, Romania, Serbia, Slovakia, Slovenia, Spain, Sweden, Switzerland, Turkey and the United Kingdom.

**iTeh STANDARD
PREVIEW
(standards.iteh.ai)**

SIST EN 16228-3:2014+A1:2022

<https://standards.iteh.ai/catalog/standards/sist/fc261dcd-5755-4955-9679-0ac5df8f648a/sist-en-16228-3-2014a1-2022>

Introduction

This document is a type C standard as stated in EN ISO 12100.

The machinery concerned and the extent to which hazards, hazardous situations and events are covered are indicated in the scope of this document.

When provisions of this type C document are different from those, which are stated in type A or B documents, the provisions of this type C document take precedence over the provisions of the other documents, for machines that have been designed and built according to the provisions of this type C document.

iTeh STANDARD PREVIEW (standards.iteh.ai)

SIST EN 16228-3:2014+A1:2022

<https://standards.iteh.ai/catalog/standards/sist/fc261dcd-5755-4955-9679-0ac5df8f648a/sist-en-16228-3-2014a1-2022>

1 Scope

This European Standard, together with part 1, deals with all significant hazards for horizontal directional drilling equipment (HDD) when they are used as intended and under the conditions of misuse which are reasonably foreseeable by the manufacturer associated with the whole life time of the machine (see Clause 4).

The requirements of this part are complementary to the common requirements formulated in **A1** EN 16228-1:2014+A1:2021 **A1**.

This document does not repeat the requirements from **A1** EN 16228-1:2014+A1:2021 **A1**, but adds or replaces the requirements for application for horizontal directional drills.

A machine is considered a horizontal directional drill if it is designed to drill in a shallow arc for the installation of pipes, conduits, and cables and typically has a drill string entry angle of less than 45° relative to the operating surface of the earth.

2 Normative references

The following documents, in whole or in part, are normatively referenced in this document and are indispensable for its application. For dated references, only the edition cited applies. For undated references, the latest edition of the referenced document (including any amendments) applies.

A1 EN 474-1:2006+A6:2019 **A1**, *Earth-moving machinery — Safety — Part 1: General requirements*

A1 EN 12999:2011+A2:2018 **A1**, *Cranes — Loader cranes*

A1 EN 16228-1:2014+A1:2021 **A1**, *Drilling and foundation equipment — Safety — Part 1: Common requirements*

EN ISO 2867:2011, *Earth-moving machinery — Access systems (ISO 2867:2011)*
<https://standards.iteh.ai/catalog/standards/sist/fc261dcd->

EN ISO 3411:2007, *Earth-moving machinery — Physical dimensions of operators and minimum operator space envelope (ISO 3411:2007)*

EN ISO 3449:2008, *Earth-moving machinery — Falling-object protective structures — Laboratory tests and performance requirements (ISO 3449:2005)*

EN ISO 3471:2008, *Earth-moving machinery — Roll-over protective structures — Laboratory tests and performance requirements (ISO 3471:2008)*

EN ISO 5353:1998, *Earth-moving machinery, and tractors and machinery for agriculture and forestry — Seat index point (ISO 5353:1995)*

EN ISO 6682:2008, *Earth-moving machinery — Zones of comfort and reach for controls (ISO 6682:1986, including Amd 1:1989)*

EN ISO 7731:2008, *Ergonomics — Danger signals for public and work areas — Auditory danger signals (ISO 7731:2003)*

EN ISO 12100:2010, *Safety of machinery — General principles for design — Risk assessment and risk reduction (ISO 12100:2010)*

A1 EN ISO 14120:2015, *Safety of machinery — Guards — General requirements for the design and construction of fixed and movable guards (ISO 14120:2015)* **A1**

EN 16228-3:2014+A1:2021 (E)

ISO 9244:2008, *Earth-moving machinery — Machine safety labels — General principles*

ISO 9533:2010, *Earth-moving machinery — Machine-mounted audible travel alarms and forward horns — Test methods and performance criteria*

ISO 11112:1995,¹ *Earth-moving machinery — Operator's seat — Dimensions and requirements*

ISO 15818:2017, *Earth-moving machinery — Lifting and tying-down attachment points — Performance requirements*

ISO 16754:2008, *Earth-moving machinery — Determination of average ground contact pressure for crawler machines*

ISO 17063:2003, *Earth-moving machinery — Braking systems of pedestrian-controlled machines — Performance requirements and test procedures*

3 Terms and definitions

For the purposes of this document, the terms and definitions given in EN ISO 12100:2010, EN 16228-1:2014+A1:2021 and the following apply.

NOTE Terminology for horizontal directional drills is specified in ISO 21467.

3.1 horizontal directional drill
machine that uses a steerable cutting head attached to the end of a drill string for creating a bore through the earth in a horizontal direction

Note 1 to entry: Drilling can include fluid injection through the drill string to the cutting head, tracking of the bore by use of sensors or a transponder near the cutting head and subsequent enlargement of the bore by back-reaming.

3.2 drill string for HDD
length of rods joined together which transmit forces from the drill frame to the cutting head or back-reamer that cuts the earth and which is also used to rotate the cutting head to position it for steering

Note 1 to entry: This terms is hereafter referred to as "drill string".

3.3 drill frame
structure on the horizontal directional drill that transmits rotational and linear forces to the drill string

3.4 ground fixation device
device by which the horizontal directional drill is secured to the ground

3.5 exit side
location remote from the base machine where the drill string exits the ground

¹) This document is impacted by Amendment 1 published in 2001.

3.6**back-reaming**

process of enlarging the bore by pulling back a tool of larger diameter than that previously used to form the bore

3.7**back-reamer**

tool of larger diameter than that previously used to form the bore

3.8**hose track**

carrier that protects, guides, and maintains proper bend radius of hydraulic hoses, electrical cables, and air hoses during movement between the stationary and moving portion of the horizontal directional drill

3.9**drill rod/pipe receiver**

structure or a method that supports the drill rod/pipe on horizontal directional drills that are not equipped with mechanical drill rod/pipe loaders

3.10**operator zone of control**

visible length of the drill pipe when seated in the operator's seat with a profile of 60° each side based on the nasal binocular field of vision assuming a fixed head and fixed eyes measured from the central position with respect to the head but the length extends only to the inside edge of the drill rod/pipe storage magazine and not beyond

Note 1 to entry: See Figure 1.

[SIST EN 16228-3:2014+A1:2022](https://standards.iteh.ai/catalog/standards/sist/fc261dcd-5755-4955-9679-0ac5df8f648a/sist-en-16228-3-2014a1-2022)

<https://standards.iteh.ai/catalog/standards/sist/fc261dcd-5755-4955-9679-0ac5df8f648a/sist-en-16228-3-2014a1-2022>

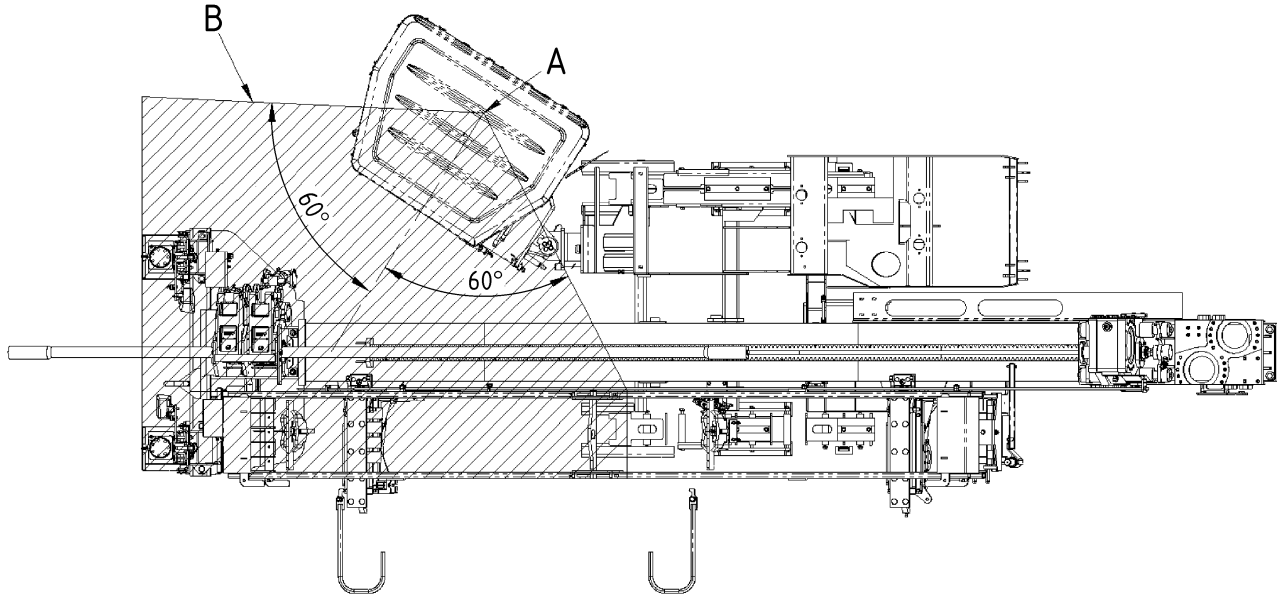
**Key**

- A seat index point
B operator zone of control

Figure 1 — Operator zone of control

4 List of additional significant hazards

Clause 4 of **EN 16228-1:2014+A1:2021** applies with the following Table 1.

Table 1 of **EN 16228-1:2014+A1:2021** and Table 1 of this document contain all hazards, hazardous situations and events, identified by risk assessments as significant for horizontal directional drilling equipment and which require action to eliminate or reduce risk.

Hazards generally occur under the following conditions:

- a) in transportation to and from the work site;
- b) in rigging and dismantling on the work site;
- c) in service on the work site;
- d) when tramming between working positions on the job site;
- e) out of service on the work site;
- f) maintenance;
- g) in storage at the plant depot or on the work site.

Table 1 — List of additional significant hazards and associated requirements

No.	Hazard	Relevant clause(s) in this standard
1	Mechanical Hazards	5.10.3
1.1	Drawing in or trapping	5.3
1.2	Entanglement	5.10.3, 5.12.3, 5.13
1.3	Crushing due to machine operation	5.6, 5.7, 5.9, 5.10.2
1.4	Crushing due to product movement	5.6
1.5	Crushing during rod/pipe connection operation	5.12.8, 5.12.9.1
1.6	Crushing during manual drill rod handling	5.12.9
2	Hazardous events due to unexpected movement	5.3
2.1	Movement of drill string/tooling at Exit side	5.13
2.2	Movement of product connected to drill string at exit side	5.13
2.3	Movement of machine from anchored position	5.2
2.4	Movement of machine (tramming) while in drilling position	5.6, 5.8
3	Hazards due to electrical contact	5.11
4	Hazards generated by noise, resulting in:	
4.1	Hearing losses and physiological disorders	Ⓐ ₁ 5.15, Ⓐ ₁ Annex B
4.2	Accidents due to interference with speech communication and warning signals	Ⓐ ₁ 5.15, Ⓐ ₁ Annex B
5	Visibility of work area	5.6.2.2, 5.11.2, 5.12.5

5 Safety requirements and/or protective measures

5.1 General

Horizontal directional drills shall comply with the requirements of Ⓐ₁ EN 16228-1:2014+A1:2021 Ⓐ₁, as far as not modified or replaced by the requirements of this part.

5.2 Stability

5.2.1 General

Ⓐ₁ EN 16228-1:2014+A1:2021, 5.2.3 Ⓐ₁ applies with the following modification(s).

The stability angle shall not be less than 10° in any direction when tramming and not less than 5° under any other conditions. Ⓐ₁ This shall be achieved by having a sufficiently heavy machine and a sufficient weight distribution (centre of gravity) and/or by the use of ground fixation devices. Ⓐ₁ Stability shall be determined by calculation or by physical test.

5.2.2 Ground pressure

Ⓐ₁ EN 16228-1:2014+A1:2021, 5.2.3.7 Ⓐ₁ applies with following modification.