



# SLOVENSKI STANDARD SIST-TS CEN/TS 1317-7:2024

01-januar-2024

Nadomešča:  
SIST ENV 1317-4:2002

---

## Oprema cest - 7. del: Ugotavljanje zmogljivosti in preskusne metode za zaključnice in prehodne elemente varnostnih ograj

Road restraint systems -Part 7: Performance characterisation and test methods for terminals of safety barriers

Rückhaltesysteme an Straßen - Leistungsklassen, Abnahmekriterien für Anprallprüfungen und Prüfverfahren für Anfangs- und Endkonstruktionen von Schutzeinrichtungen

Dispositifs de retenue routiers Caractérisation des performances et méthodes d'essai pour les extrémités de file de barrières de sécurité

Ta slovenski standard je istoveten z: **CEN/TS 1317-7:2023**

---

### ICS:

13.200	Preprečevanje nesreč in katastrof	Accident and disaster control
93.080.30	Cestna oprema in pomožne naprave	Road equipment and installations

**SIST-TS CEN/TS 1317-7:2024** en,fr,de



TECHNICAL SPECIFICATION  
SPÉCIFICATION TECHNIQUE  
TECHNISCHE SPEZIFIKATION

**CEN/TS 1317-7**

November 2023

ICS 93.080.30

Supersedes ENV 1317-4:2001

English Version

**Road restraint systems -Part 7: Performance  
characterisation and test methods for terminals of safety  
barriers**

Dispositifs de retenue routiers - Caractérisation des performances et méthodes d'essai pour les extrémités de file de barrières de sécurité

Rückhaltesysteme an Straßen - Leistungsklassen, Abnahmekriterien für Anprallprüfungen und Prüfverfahren für Anfangs- und Endkonstruktionen von Schutzeinrichtungen

This Technical Specification (CEN/TS) was approved by CEN on 4 September 2023 for provisional application.

The period of validity of this CEN/TS is limited initially to three years. After two years the members of CEN will be requested to submit their comments, particularly on the question whether the CEN/TS can be converted into a European Standard.

CEN members are required to announce the existence of this CEN/TS in the same way as for an EN and to make the CEN/TS available promptly at national level in an appropriate form. It is permissible to keep conflicting national standards in force (in parallel to the CEN/TS) until the final decision about the possible conversion of the CEN/TS into an EN is reached.

CEN members are the national standards bodies of Austria, Belgium, Bulgaria, Croatia, Cyprus, Czech Republic, Denmark, Estonia, Finland, France, Germany, Greece, Hungary, Iceland, Ireland, Italy, Latvia, Lithuania, Luxembourg, Malta, Netherlands, Norway, Poland, Portugal, Republic of North Macedonia, Romania, Serbia, Slovakia, Slovenia, Spain, Sweden, Switzerland, Türkiye and United Kingdom.

Document Preview

[SIST-TS CEN/TS 1317-7:2024](https://standards.iteh.ai/catalog/standards/sist/12e9dde8-eddb-4c9e-84c3-20a6c5efb0aa/sist-ts-cen-ts-1317-7-2024)

<https://standards.iteh.ai/catalog/standards/sist/12e9dde8-eddb-4c9e-84c3-20a6c5efb0aa/sist-ts-cen-ts-1317-7-2024>



EUROPEAN COMMITTEE FOR STANDARDIZATION  
COMITÉ EUROPÉEN DE NORMALISATION  
EUROPÄISCHES KOMITEE FÜR NORMUNG

**CEN-CENELEC Management Centre: Rue de la Science 23, B-1040 Brussels**

<b>Contents</b>	<b>Page</b>
<b>European foreword</b> .....	<b>4</b>
<b>Introduction</b> .....	<b>5</b>
<b>1 Scope</b> .....	<b>6</b>
<b>2 Normative references</b> .....	<b>6</b>
<b>3 Terms and definitions</b> .....	<b>6</b>
<b>4 Abbreviations</b> .....	<b>11</b>
<b>5 Terminal performance</b> .....	<b>11</b>
<b>5.1 General</b> .....	<b>11</b>
<b>5.2 Determination of the Datum Point and Structural Length</b> .....	<b>11</b>
<b>5.3 Restraint and direction categories</b> .....	<b>12</b>
<b>5.3.1 General</b> .....	<b>12</b>
<b>5.3.2 Impact points</b> .....	<b>16</b>
<b>5.4 Tests for ranges of terminals</b> .....	<b>18</b>
<b>5.5 Impact severity</b> .....	<b>21</b>
<b>5.6 Static, dynamic and total permanent displacements of terminal</b> .....	<b>21</b>
<b>5.7 Impact test acceptance criteria</b> .....	<b>22</b>
<b>5.7.1 General</b> .....	<b>22</b>
<b>5.7.2 Terminal behaviour</b> .....	<b>23</b>
<b>5.7.3 Test vehicle behaviour</b> .....	<b>23</b>
<b>5.7.4 Test vehicle deformation</b> .....	<b>27</b>
<b>5.7.5 Severity index</b> .....	<b>27</b>
<b>5.8 Anchorage capacity</b> .....	<b>27</b>
<b>6 Test methods</b> .....	<b>28</b>
<b>6.1 Test site</b> .....	<b>28</b>
<b>6.2 Test vehicles</b> .....	<b>28</b>
<b>6.3 Test item</b> .....	<b>28</b>
<b>6.3.1 General</b> .....	<b>28</b>
<b>6.3.2 Installation</b> .....	<b>28</b>
<b>6.4 Accuracies and limit deviations of impact speeds and approach angle</b> .....	<b>29</b>
<b>6.4.1 Vehicle impact speed</b> .....	<b>29</b>
<b>6.4.2 Vehicle approach angle</b> .....	<b>29</b>
<b>6.4.3 Combined limit deviation of speed and angle</b> .....	<b>29</b>
<b>6.5 Vehicle impact point</b> .....	<b>29</b>
<b>6.6 Vehicle instrumentation</b> .....	<b>29</b>
<b>6.7 Photographic coverage</b> .....	<b>30</b>
<b>6.8 Test report</b> .....	<b>31</b>
<b>Annex A (normative) Detailed test report template</b> .....	<b>32</b>
<b>Annex B (informative) Objective of each of the impact tests and guidelines for determination of impact points and exit box</b> .....	<b>39</b>
<b>Annex C (informative) Assessment of the anchorage capacity</b> .....	<b>46</b>
<b>C.1 General</b> .....	<b>46</b>
<b>C.2 Static calculation of anchorage capacity of terminals – basic assumptions</b> .....	<b>46</b>

<b>C.2.1</b>	<b>General .....</b>	<b>46</b>
<b>C.2.2</b>	<b>Anchorage by friction.....</b>	<b>46</b>
<b>C.2.3</b>	<b>Anchorage by anchors in pavement.....</b>	<b>46</b>
<b>C.2.4</b>	<b>Anchorage of devices (e.g. posts) driven through or in pavement .....</b>	<b>46</b>
<b>C.2.5</b>	<b>Anchorage of devices (e.g. posts) driven in soil.....</b>	<b>46</b>
<b>C.2.6</b>	<b>Anchorage not covered by C.2.2 to C.2.4.....</b>	<b>48</b>
<b>C.3</b>	<b>Measurement of anchorage capacity of terminals.....</b>	<b>48</b>
	<b>Bibliography .....</b>	<b>49</b>

**iTeh Standards**  
**(<https://standards.iteh.ai>)**  
**Document Preview**

[SIST-TS CEN/TS 1317-7:2024](https://standards.iteh.ai/catalog/standards/sist/12e9dde8-eddb-4c9e-84c3-20a6c5efb0aa/sist-ts-cen-ts-1317-7-2024)

<https://standards.iteh.ai/catalog/standards/sist/12e9dde8-eddb-4c9e-84c3-20a6c5efb0aa/sist-ts-cen-ts-1317-7-2024>

**CEN/TS 1317-7 :2023 (E)****European foreword**

This document (CEN/TS 1317-7 :2023) has been prepared by Technical Committee CEN/TC 226 “Road equipment”, the secretariat of which is held by AFNOR.

Attention is drawn to the possibility that some of the elements of this document may be the subject of patent rights. CEN shall not be held responsible for identifying any or all such patent rights.

This document supersedes ENV 1317-4:2001.

This document does not (and cannot) replace ENV 1317-4:2001 in isolation, only with CEN/TR 1317-10 and CEN/TS 1317-9.

In comparison with the edition, the following technical modifications have been made:

- terminal with performances on both sides defined in 3.3 (double-sided terminals)
- structural beginning of a terminal defined in 3.5 (datum point)
- structural length of a terminal defined in 3.7
- energy absorbing terminal defined in 3.10
- non-energy absorbing terminal defined in 3.11
- determination of the axial force to the barrier determined in 5.1
- methods for the determination of the Datum Point and the Structural Length are given in 5.2
- more restraint categories and different names are given for terminals in Table 1
- more vehicle impact tests are defined in Table 3
- the term “ranges of terminals” supersedes “system type tested terminals” in 5.4
- limit of 6.0m to the total permanent displacement of terminal on the departure side in Table 8
- for the terminal behaviour, consideration of totally detached parts of the terminal with mass greater than 2.0 kg in 5.7.2
- for the test vehicle behaviour, the wheel of a vehicle is not considered crossing one of the lines of the redirection zone, if the velocity of the centre of mass of the vehicle, at the moment of encroaching the line, is less than 11 km/h and advice for the measurement of exit speed are given in 5.7.3
- definition of new terminal energy absorption categories are given in Table 10
- the anchorage capacity of the terminal is measured in 5.8
- different layout of cameras for different approaches are given in 6.7
- objective of the impact tests and guidelines for determination of impact points and exit box is detailed in informative Annex B
- the assessment of the anchorage capacity is detailed in the informative Annex C

This document is to be read in conjunction with EN 1317-1:2010 and EN 1317-2:2010 and EN 1317-5:2007+A2:2012 and CEN/TR 1317-10.

Any feedback and questions on this document should be directed to the users’ national standards body. A complete listing of these bodies can be found on the CEN website.

## Introduction

The design purpose of safety barriers installed on roads is to contain errant vehicles that either leave the carriageway or are likely to encroach into the path of oncoming vehicles. EN 1317-2:2010 deals with the impact performance of a safety barrier to which a terminal may be attached.

Terminals, which are defined as the beginning and/or end treatment of a safety barrier, are required to have specified impact performances without introducing additional hazards for passenger cars.

The description of a terminal conforming to this document incorporates the relevant categories and restraint categories of the product.

Turned down terminals are particular end-treatments that have, historically, been designed to 'anchor' and 'end' sections of safety barrier. Turned down terminals consisting of modified components of the barrier do not generally offer a significant level of energy absorbing capacity but can be tested according to this technical specification if required.

NOTE Some National Road Authorities have in the past years developed national rules that, when satisfied, allow the use of such systems within their national jurisdiction without the need of further testing.

In this document reference is made to the use of virtual testing according to EN 16303:2020. Therefore it may be necessary to arrange further rules for the use of virtual testing.

# iTeh Standards (<https://standards.iteh.ai>) Document Preview

[SIST-TS CEN/TS 1317-7:2024](https://standards.iteh.ai/catalog/standards/sist/12e9dde8-eddb-4c9e-84c3-20a6c5efb0aa/sist-ts-cen-ts-1317-7-2024)

<https://standards.iteh.ai/catalog/standards/sist/12e9dde8-eddb-4c9e-84c3-20a6c5efb0aa/sist-ts-cen-ts-1317-7-2024>

## CEN/TS 1317-7 :2023 (E)

### 1 Scope

This document specifies requirements, test/assessment methods and acceptance criteria for safety barrier terminals to be used in a permanent or temporary manner on roads and in vehicle circulation areas.

### 2 Normative references

The following documents are referred to in the text in such a way that some or all of their content constitutes requirements of this document. For dated references, only the edition cited applies. For undated references, the latest edition of the referenced document (including any amendments) applies.

EN 1317-1:2010, *Road restraint systems - Part 1: Terminology and general criteria for test methods*

EN 1317-2:2010, *Road restraint systems - Part 2: Performance classes, impact test acceptance criteria and test methods for safety barriers including vehicle parapets*

EN 16303:2020, *Road restraint systems - Validation and verification process for the use of virtual testing in crash testing against vehicle restraint system*

### 3 Terms and definitions

For the purposes of this document, the following terms and definitions apply.

ISO and IEC maintain terminological databases for use in standardization at the following addresses:

- IEC Electropedia: available at <https://www.electropedia.org/>
- ISO Online browsing platform: available at <https://www.iso.org/obp>

#### 3.1 terminal

treatment of the beginning and/or end of a safety barrier to reduce hazards for passenger cars that would result from the use of an un-treated beginning or end of the barrier (or other construction)

Note 1 to entry: Usually a terminal provides anchorage for the barrier system.

Note 2 to entry: A terminal may include a length of connecting barrier if it is required as part of the working mechanism of the terminal

Note 3 to entry: The performance of a terminal in general is dependent on the barrier connected.

#### 3.2 ST single sided terminal

terminal which has a performance under impact determined in accordance with the present document on one side

#### 3.3 DT double-sided terminal

terminal which has performance in accordance with this European Standard, on both sides



**3.4****turned down terminal**

end treatment or terminal consisting mainly of a longitudinal element lowered continuously close to the ground

Note 1 to entry Historically, turned down terminals have been designed to ‘anchor’ and ‘end’ sections of safety barrier in addition to providing better safety at the beginning of barriers.”

Note 2 to entry: Turned down terminals consisting of modified components of the barrier do not generally offer a significant level of energy absorbing capacity but can be tested according to this technical specification if required by national rules.

**3.5****datum point**

structural beginning of a terminal i.e. the first point at which the terminal offers significant resistance to a frontal impact

**3.6****total length of a terminal****L<sub>t</sub>**

total length of the terminal including structural and non-structural components including the length of connecting barrier required as part of the working mechanism of the terminal

**3.7****structural length of a terminal****L<sub>s</sub>**

longitudinal distance from the terminal datum point to the end of the terminal including the length of connecting barrier required as part of the working mechanism of the terminal

Note 1 to entry: The structural length as well as the total length of a terminal is measured in the direction of the traffic side of the barrier. Both lengths are shown diagrammatically in Figure 3.

**3.8****length of attached barrier****L<sub>b</sub>**

length L<sub>b</sub> of a barrier meeting the requirements of EN 1317-1 and EN 1317-2 and fixed to a terminal for the crash test including connections

**3.9****length of terminal deformation****L<sub>d</sub>**

maximum dynamic longitudinal displacement of the terminal datum point after Approach 1 test

**3.10****energy absorbing terminal****EAT**

terminal which in the test Approach 1 (or 2 for T50, T80/3, T80/2 and T80/1) does not allow the most forward point of the test vehicle to cross the vehicle exit line R (see Figure 7) at a speed higher or equal to 11 km/h

**CEN/TS 1317-7 :2023 (E)****3.11****non-energy absorbing terminal****NEAT**

terminal which in the test Approach 1 (or 2 for T50, T80/3, T80/2 and T80/1) allows the most forward point of the test vehicle to cross the vehicle exit line R (see Figure 7) at a speed higher or equal to 11 km/h

**3.12****range of terminals**

multiple performance product that can be assembled to form different models from the same set of components, to obtain performances in different categories, with the same working mechanism for the system and for its components

**3.13****wheel track**

distance between the centres of tyre contact of the two wheels of an axle, projected on to the YZ plane

Note 1 to entry: See Figure 1.

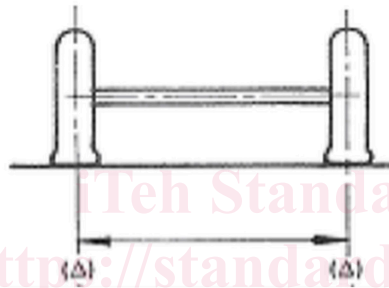
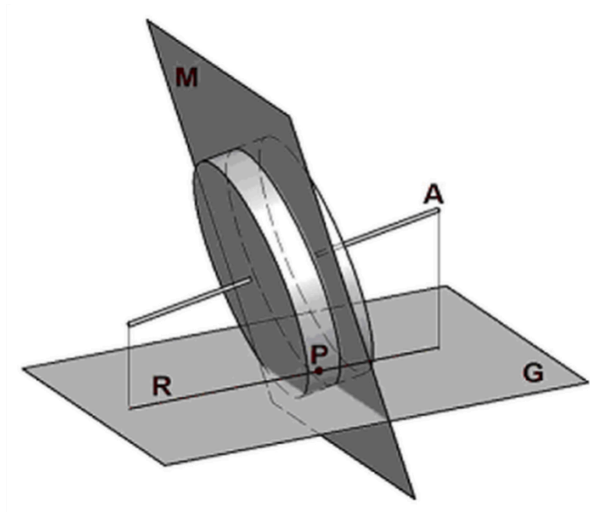

**Figure 1 — Example of wheel track**

**3.14****centre of tyre contact**

P centre of tyre contact

Note 1 to entry: See Figure 2

**Key**

- A wheel spin axis
- G ground plane
- M wheel mid plane
- R projection of A on G
- P centre of tyre contact

**Figure 2 — Centre of tyre contact****3.15****critical impact point  
CIP**

impact point identified to reasonably represent the worst case performance under test conditions

**3.16****uni-directional terminal – approach****UTA**

terminal designed and tested to perform at the approach end of a barrier only

**3.17****uni-directional terminal – departure****UTD**

terminal designed and tested to perform at the departure end of a barrier only

**3.18****bi-directional terminal****BDT**

terminal designed and tested to perform at either the approach end or the departure end of a barrier

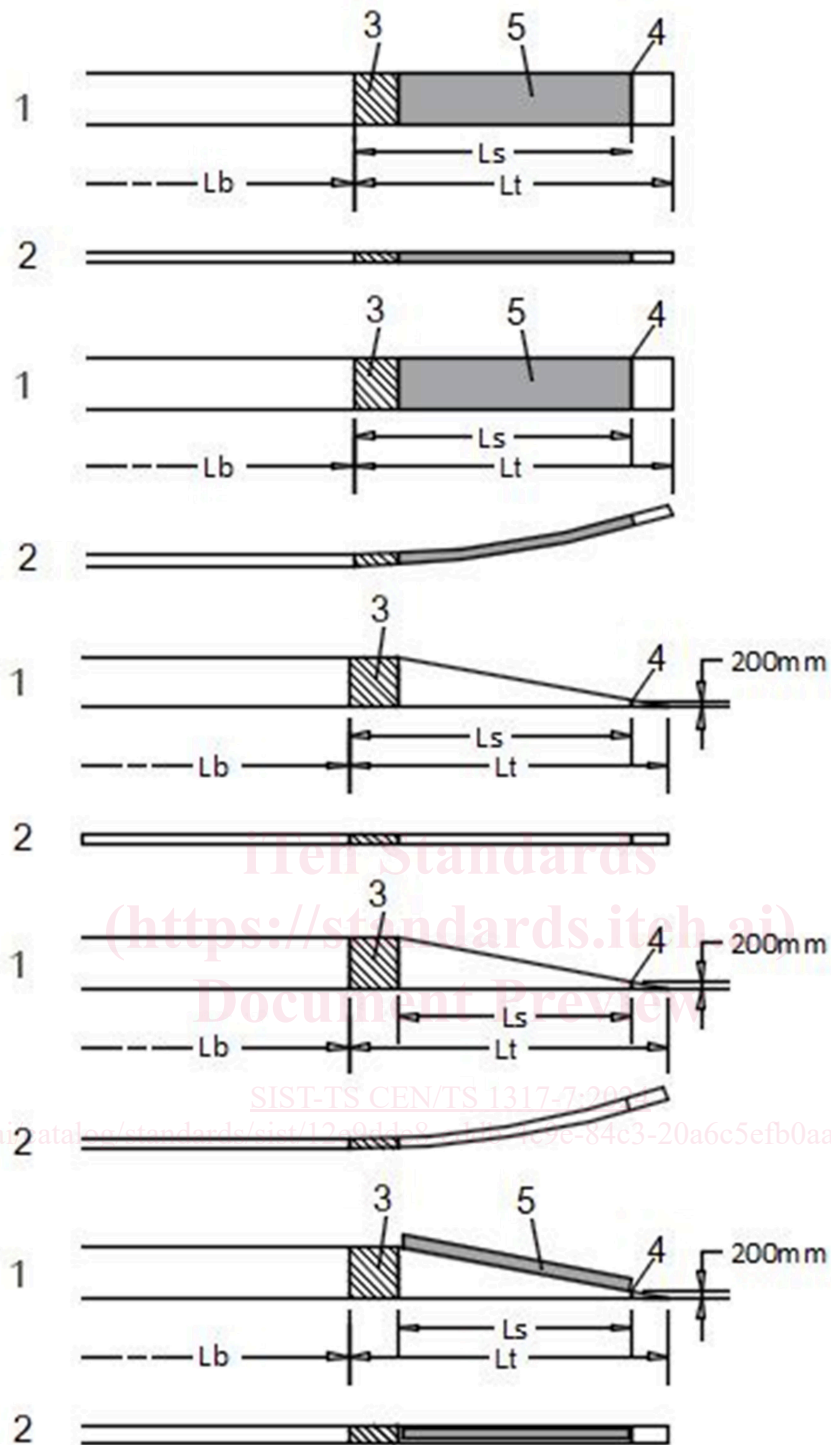
**Key**

- 1 side view
- 2 plan view
- 3 minimum length of connecting barrier required as part of the working mechanism of the terminal
- 4 datum point
- 5 energy absorbing element

**Figure 3 — Diagram of a Terminal**

## 4 Abbreviations

For the purposes of this document, the following abbreviations apply.

ASI	Acceleration severity index
ATD	Anthropomorphic Test Device
BDT	Bi-directional terminal
CIP	Critical Impact Point
DT	Double sided terminal
EAT	Energy Absorbing Terminal
Lb	Length of barrier connected to a terminal
Ld	Length of terminal deformation
Ls	Structural length of a terminal
Lt	Total length of a terminal
NEAT	Non-energy Absorbing Terminal
ST	Single sided terminal
THIV	Theoretical head impact velocity
UTA	Uni-directional terminal approach
UTD	Uni-directional terminal departure
VCDI	Vehicle cockpit deformation index

For the purposes of this document, test vehicle mass codes are

- 1 900 kg,
- 2 1 300 kg,
- 3 1 500 kg.

## 5 Terminal performance

### 5.1 General

Axial forces to the barrier should be measured or evidence should be given by static calculation or by virtual testing using models according to EN 16303:2020, if it is intended to use the terminal with different barriers, unless the terminal does not transfer any load to the connecting barrier.

### 5.2 Determination of the Datum Point and Structural Length

The structural length of the terminal ( $L_s$ ) should be determined by the test house, after the Approach 1 test has been performed if this approach is required (or, after that of Approach 2 if no Approach 1 test is required) before the other required tests are performed. Some designs of terminal might incorporate a non-structural beginning (nose) which offers no significant influence (for example resistance) to an impact. The first point at which the terminal offers significant influence (for example resistance) to an impact with Approach 1 is defined as the datum point. For restraint categories T50 and T80/1/2/3, this information can be derived from Approach 2.

The datum point should be chosen by the test house according to the definition given in 3.5 and identified as described above and justified in the test report. If the datum point cannot be chosen directly from the

## CEN/TS 1317-7 :2023 (E)

design of the terminal or the manufacturer does not agree to the chosen datum point the datum point should be determined by the test house on the basis of the results of the Approach 1 test if this approach is required (or, on that of Approach 2 if no Approach 1 test is required). For energy absorbing terminals the datum point is the foremost point of the test item where the test vehicle has lost 5 % of the nominal impact speed.

For turned down terminals, the terminal datum point should be defined as the first point 200 mm above ground level.

**NOTE** The speed of the test vehicle could be derived from the vehicle instrumentation or from high speed video and the corresponding vehicle position from high speed video or another suitable method can be used.

If a part of the barrier overlaps with the terminal or is required to deform in a controlled manner as part of the normal functioning of the terminal, then this length of the barrier should be included in  $L_s$ . For turned down terminals the length of the terminal should be the longitudinal length from the beginning of the terminal to the first point of the barrier with unchanged design (including full height of the barrier).

The total length of the terminal ( $L_t$ ) should conform to the design specification. For tests, the terminal should be installed with the terminal manufacturer's minimum specified length of safety barrier ( $L_b$ ) so as to demonstrate the full performance of the terminal but not shorter than 20 m. For tests that were carried out in accordance with ENV 1317-4:2001 before this document was published, a shorter length is acceptable, provided the full performance of the terminal is demonstrated. The same barrier type should be used within all of the testing for a particular terminal product.

### 5.3 Restraint and direction categories

#### 5.3.1 General

Terminals should be tested in accordance with Table 1 and Table 3. The restraint categories given in Table 1 are classified according to an increasing containment capacity.

A successfully tested installation at a given restraint category, should be considered as having met conditions of lower restraint categories with the same direction category (see Table 2).

The impact test configurations are specified in Table 3.

**NOTE 1** Some of the performances of terminals are common to crash cushions. Accordingly, some of the tests specified for terminals in the present document have the same impact conditions specified in EN 1317-3:2010 for crash cushions. Nevertheless, some other tests are different. The main differences between terminals and crash cushions are:

- for terminals:
  - o a terminal is designed to be installed at the beginning and/or at the end of a barrier whereas a crash cushion is intended to avoid or attenuate vehicle impacts with different types of obstacle,
  - o a terminal should be joined to a barrier, with a smooth alignment with no risk of snagging or pocketing,
  - o in general a terminal is designed to provide an anchorage to the barrier and to have adequate reaction to the axial tensile force from the barrier under impact.

The above three points might also apply to crash cushions connected to a barrier.

- for crash cushions:
  - o a crash cushion can be connected to the obstacle that it protects,
  - o a crash cushion is always energy absorbing while a terminal can be NEAT.