**Organization and digitization of
information about buildings and civil
engineering works, including building
information modelling (BIM) —
Information management using
building information modelling —**

**Part 3:
Operational phase of the assets**

*Organisation et numérisation des informations relatives aux
bâtiments et ouvrages de génie civil y compris modélisation des
informations de la construction (BIM) — Gestion de l'information par
la modélisation des informations de la construction —*

Partie 3: Phase d'exploitation des actifs



iTeh STANDARD PREVIEW
(standards.iteh.ai)

ISO 19650-3:2020

<https://standards.iteh.ai/catalog/standards/sist/21b02de5-11d8-4e50-aceb-baa4c2b8a082/iso-19650-3-2020>



COPYRIGHT PROTECTED DOCUMENT

© ISO 2020

All rights reserved. Unless otherwise specified, or required in the context of its implementation, no part of this publication may be reproduced or utilized otherwise in any form or by any means, electronic or mechanical, including photocopying, or posting on the internet or an intranet, without prior written permission. Permission can be requested from either ISO at the address below or ISO's member body in the country of the requester.

ISO copyright office
CP 401 • Ch. de Blandonnet 8
CH-1214 Vernier, Geneva
Phone: +41 22 749 01 11
Email: copyright@iso.org
Website: www.iso.org

Published in Switzerland

Contents

Page

Foreword	v
Introduction	vi
1 Scope	1
2 Normative references	1
3 Terms, definitions, and symbols	1
3.1 Terms and definitions.....	1
3.2 Symbols for process diagrams.....	2
4 Information management associated with the operational phase of assets	2
4.1 Information management process associated with the operational phase of assets.....	2
4.2 Relationship between this document and ISO 19650-2.....	4
5 Information management process to support the operational phase of assets	4
5.1 Information management process — assessment and need.....	4
5.1.1 Appoint individuals to undertake the information management function.....	4
5.1.2 Establish organizational information requirements.....	4
5.1.3 Identify the assets for which information shall be managed.....	5
5.1.4 Establish the asset information requirements.....	5
5.1.5 Identify the foreseeable trigger events for which information shall be managed..	5
5.1.6 Establish the asset information standard.....	6
5.1.7 Establish the asset information production methods and procedures.....	6
5.1.8 Establish the reference information and shared resources.....	6
5.1.9 Establish the common data environment.....	7
5.1.10 Establish links to enterprise systems.....	7
5.1.11 Establish the asset information model.....	7
5.1.12 Establish processes to maintain the AIM.....	8
5.1.13 Establish the asset information protocol.....	8
5.1.14 Activities for assessment and need.....	9
5.2 Information management process — Invitation to tender/request to provide service.....	9
5.2.1 Decide the type of activity providing information.....	9
5.2.2 Establish the appointing party's exchange information requirements.....	10
5.2.3 Assemble reference information and shared resources.....	10
5.2.4 Establish response requirements and evaluation criteria.....	10
5.2.5 Compile information for the invitation to tender/request to provide service.....	11
5.2.6 Activities for invitation to tender/request to provide service.....	11
5.3 Information management process — Response to invitation to tender/request to provide service.....	12
5.3.1 Nominate individuals to undertake the information management function.....	12
5.3.2 Establish the delivery team's (pre-appointment) BIM execution plan.....	12
5.3.3 Assess task team capability and capacity.....	12
5.3.4 Establish the delivery team's capability and capacity.....	13
5.3.5 Establish the delivery team's mobilization plan.....	13
5.3.6 Establish the delivery team's risk register.....	13
5.3.7 Compile the delivery team's response.....	13
5.3.8 Activities for response to invitation to tender/request to provide service.....	14
5.4 Information management process — Appointment.....	14
5.4.1 Confirm the delivery team's BIM execution plan.....	14
5.4.2 Establish the delivery team's detailed responsibility matrix.....	15
5.4.3 Establish the lead appointed party's EIR (ISO 19650-3).....	15
5.4.4 Establish the task information delivery plan(s).....	15
5.4.5 Establish the master information delivery plan.....	15
5.4.6 Complete lead appointed party's appointment.....	16
5.4.7 Complete appointed party's appointment.....	16
5.4.8 Activities for appointment.....	16

5.5	Information management process — Mobilization	17
5.5.1	Mobilize resources	17
5.5.2	Mobilize information technology	17
5.5.3	Test the asset information production methods and procedures	18
5.5.4	Maintain resources in readiness for a trigger event	18
5.5.5	Activities for mobilization	18
5.6	Information management process — Production of information	19
5.6.1	Check availability of reference information and shared resources	19
5.6.2	Generate information	19
5.6.3	Undertake quality assurance check	19
5.6.4	Review information and approve for sharing	20
5.6.5	Review information model	20
5.6.6	Authorize information model for delivery to the appointing party	20
5.6.7	Activities for production of information	21
5.7	Information management process — Information model acceptance by appointing party	22
5.7.1	Submit information model for appointing party acceptance	22
5.7.2	Review and accept the information model	22
5.7.3	Activities for information model acceptance by appointing party	22
5.8	Information management process — AIM aggregation	23
5.8.1	Aggregate an accepted information model into the AIM	23
5.8.2	Review and continue maintenance of the AIM	23
5.8.3	Activities for AIM aggregation	23
Annex A (informative) Guidance related to the information management process		25
Bibliography		30

ITeH STANDARD PREVIEW
 (standards.iteh.ai)

<https://standards.iteh.ai/catalog/standards/sist/21b02de5-11d8-4e50-aceb-baa4c2b8a082/iso-19650-3-2020>

Foreword

ISO (the International Organization for Standardization) is a worldwide federation of national standards bodies (ISO member bodies). The work of preparing International Standards is normally carried out through ISO technical committees. Each member body interested in a subject for which a technical committee has been established has the right to be represented on that committee. International organizations, governmental and non-governmental, in liaison with ISO, also take part in the work. ISO collaborates closely with the International Electrotechnical Commission (IEC) on all matters of electrotechnical standardization.

The procedures used to develop this document and those intended for its further maintenance are described in the ISO/IEC Directives, Part 1. In particular, the different approval criteria needed for the different types of ISO documents should be noted. This document was drafted in accordance with the editorial rules of the ISO/IEC Directives, Part 2 (see www.iso.org/directives).

Attention is drawn to the possibility that some of the elements of this document may be the subject of patent rights. ISO shall not be held responsible for identifying any or all such patent rights. Details of any patent rights identified during the development of the document will be in the Introduction and/or on the ISO list of patent declarations received (see www.iso.org/patents).

Any trade name used in this document is information given for the convenience of users and does not constitute an endorsement.

For an explanation of the voluntary nature of standards, the meaning of ISO specific terms and expressions related to conformity assessment, as well as information about ISO's adherence to the World Trade Organization (WTO) principles in the Technical Barriers to Trade (TBT), see www.iso.org/iso/foreword.html.

This document was prepared by ISO/TC 59, *Buildings and civil engineering works*, SC 13, *Organization and digitization of information about buildings and civil engineering works, including building information modelling (BIM)*, in collaboration with the European Committee for Standardization (CEN) Technical Committee CEN/TC 442, *Building Information Modelling (BIM)*, in accordance with the Agreement on technical cooperation between ISO and CEN (Vienna Agreement).

A list of all parts in the ISO 19650 series can be found on the ISO website.

Any feedback or questions on this document should be directed to the user's national standards body. A complete listing of these bodies can be found at www.iso.org/members.html.

Introduction

0.1 Purpose and application

This document is designed to enable an appointing party (such as an asset owner, asset operator or outsourced asset management provider) to establish their requirements for information during the operational phase of an asset. This document is also designed to enable them to provide the appropriate collaborative environment to fulfil commercial goals. Within this environment, multiple appointed parties can produce information in an effective and efficient manner.

This document is primarily intended for use by the following:

- those involved in the management of an asset and facility (see 0.2);
- those involved in the specification of appointments and the facilitation of collaborative working during the entire life cycle of an asset;
- those involved in delivering asset management and facility management during the operational phase of an asset (see 0.2); and
- those involved in specifying the information required for operational purposes that needs to be captured during the delivery phase of an asset.

If this document is being applied in relation to a particular asset then this should be reflected in the relevant appointments.

This document is applicable to assets of all sizes and all levels of complexity. This includes portfolios of buildings, campuses, infrastructure networks, individual buildings and pieces of infrastructure such as roads, bridges, footpaths, streetlights, water pipes or sewers. The requirements in this document should be applied in a way that is proportionate and appropriate to the scale and complexity of the asset.

Continuity of information management over the lifetime of an asset is important and it is recommended that all feasible steps (including transfer of the asset information model) are taken to ensure this whenever an asset is transferred from one owner to another.

[Figure 1](#) shows the application of information management during the operational phase (shaded) in conjunction with the delivery phase (unshaded apart from points A and B where information is transferred). [Figure 1](#) also shows how information management according to the ISO 19650 series takes place within the context of asset and project management which itself takes place within the context of organizational management. ISO 9001, ISO 55000 and ISO 21500, indicated in [Figure 1](#), are not requirements for applying this document.

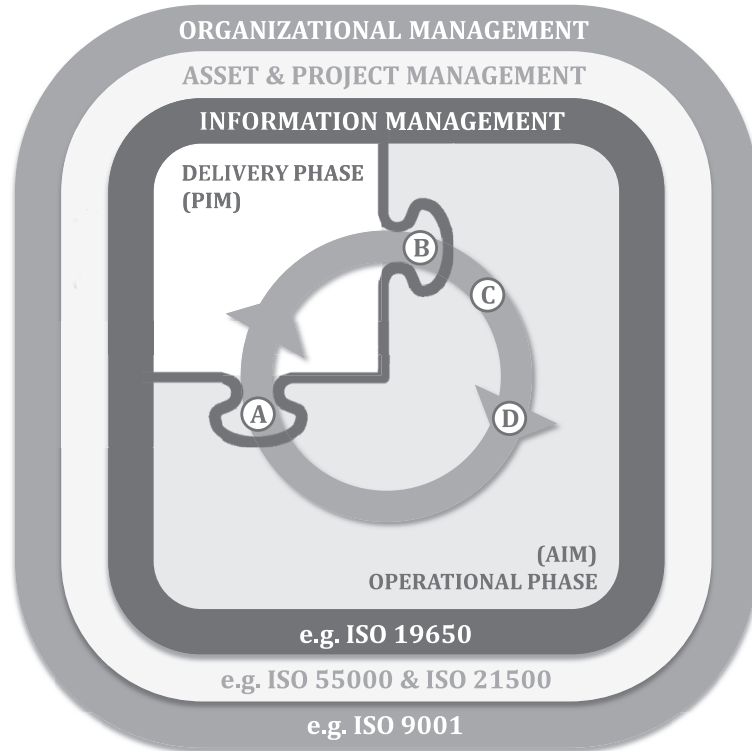

Key

AIM asset information model

PIM project information model

A start of delivery phase — transfer of relevant information from AIM to PIM

B start of operational phase — transfer of relevant information from PIM to AIM

C post-occupancy/implementation evaluation or performance review

D trigger events during the operational phase

NOTE Information can be transferred between PIM and AIM during the delivery phase as well as at points A and B.

iTeh STANDARD PREVIEW
(standards.iteh.ai)

Figure 1 — Scope of this document

The concepts and principles from ISO 19650-1, concerning different forms of information requirements, have been applied in this document. The application of these concepts and principles has been tailored to respond to the particular nature of asset management activities. In support of this, a simplified illustration of the progression of information requirements is shown in [Figure 2](#).

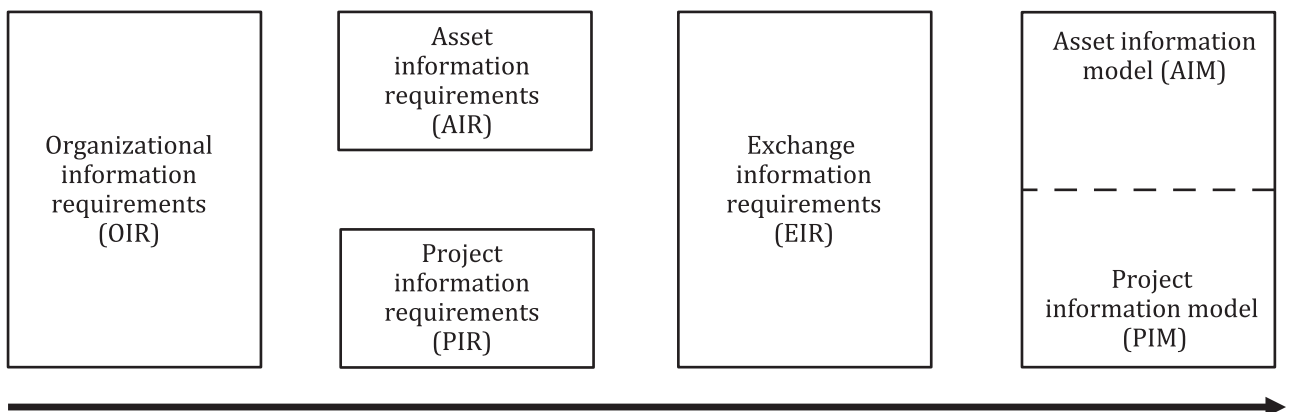

Figure 2 — Simplified illustration of the progression of information requirements

The information management process specified in this document can be applied to trigger events that are foreseen and scheduled in advance as well as to trigger events that are not scheduled in advance or cannot be foreseen. These two types of trigger event differ in terms of when the preparatory activities of identifying and appointing the lead appointed party can take place.

Examples of the first type of trigger event are: annual maintenance tasks, strategic estate reviews and call-off arrangements for common-place repairs. For this type of trigger event, it is possible and sensible to select and appoint the lead appointed party well before any of these trigger events takes place.

For the second type of trigger event there are two distinct scenarios. The first is the deliberate decision to initiate a project such as the construction of a bridge or underpass. Here, the information management process could follow either ISO 19650-2 or this document. The decision will depend on the scale and complexity and the requirements on those involved are stated in 4.2. The second scenario includes trigger events that are so rare or unpredictable that having appointments in place can be inappropriate or not possible. The selection and appointment occur after the trigger event takes place. Examples include unexpected breakdowns of equipment, accidents and extreme floods.

Finally, there is the separate situation of an asset being acquired from an existing owner, where information is exchanged as part of the transaction.

All these situations are catered for in the arrangement of [Clause 5](#). [Annex A](#) provides guidance to support some of the requirements contained in [Clause 5](#). [Clause 5](#) also includes illustrations of the breakdown of each step in the information management process and a reminder of where each step comes in the overall process, in [Figures 5](#) to [12](#).

0.2 Asset management and facility management

Asset management and facility management have developed as two distinct management disciplines, despite both of them being concerned with managing the physical assets and services of an organization. Asset management and facility management have developed their own standards and language of preferred terms.

This document recognizes that both asset management and facility management play their own part in the lifecycle of an asset, but for simplicity the main body of this document use the term asset management to cover both disciplines.

0.3 Use of phrase “shall consider”

This document makes use of the phrase “shall consider”, particularly in [Clause 5](#). This phrase is used to introduce a list of items that the person in question needs to think about carefully in connection with the primary requirement described in the subclause. The amount of thought involved, the time taken to complete it, and the need for supporting evidence will depend on the complexity of the asset, the experience of the person(s) involved, and the requirements of any national policy on building information modelling. On a relatively small or straightforward asset, it can be possible to complete, or dismiss as not relevant, some of these “shall consider” items very quickly.

One way to help identify which of the “shall consider” statements are relevant can be to review each statement and create templates for assets of different sizes and complexity.

0.4 National annex with relevant national standards

There are several standards required for the successful implementation of this document, relating to specific regions or countries, that are currently not suitable for inclusion within an international standard. As such, national standards bodies are encouraged to compile and document the standards, relevant to the region or country they represent, within a national annex. National annexes can also provide localized guidance and advice on how to implement this document for assets and trigger events of varying complexity.

0.5 Relationship with other standards

The concepts and principles relating to the application of the requirements within this document are provided in ISO 19650-1. Requirements for a security-minded approach to managing asset information are provided in ISO 19650-5.

For those occasions when the operational phase of an asset leads into a delivery phase, the requirements provided in ISO 19650-2 should be used in conjunction with this document.

General information on a management system for asset management, including terminology applicable to asset management, can be found in ISO 55000. General information on a management system for facility management can be found in ISO 41001 and ISO 41011.

Consideration of the concepts and principles contained within both ISO 19650-1 and ISO 55000 can assist appointing parties with the implementation of the requirements of this document and the development of asset management in their organization.

0.6 Benefits of this document

The aim of this document is to support all parties towards achieving their business objectives through effective and efficient production, use and management of information during the operational and end of life phases of assets where building information modelling is used.

International cooperation in the preparation of this document has identified a common information management process that can be applied to the broadest range of assets. This applies to the broadest range of organizations, across the broadest range of cultures, under the broadest range of appointment routes.

The benefits of the information management process should be kept under review during the operational phase of the asset life cycle and this should be done through regular formal reviews of the costs and benefits of the entire process to all parties.

0.7 Interfaces between parties and teams for the purpose of information management

For the purpose of this document, [Figure 3](#) shows the interfaces between parties and teams with respect to information management in the operational phase and should not be seen as indicating contractual relationships.

The appointing party referred to in [Figure 3](#) can be the owner of the asset, the operator of the asset (for example through a long-term concession agreement), or the outsourced asset or facility manager (typically appointed for a period of several years).

Delivery teams for the operational phase typically join and leave the asset/facility management and operation team at any appropriate time during the life cycle of the asset. Where information is produced by a task team within the appointing party's organization, for example a maintenance department, that task team should still comply with the requirements of this document as an appointed party or as a lead appointed party.

[Figure 3](#) shows that delivery teams for asset management and operation activities can be of varying size and complexity and can include different numbers of task teams. Where multiple delivery teams are appointed at the same time, the appointing party can require them to coordinate their production of information with each other.

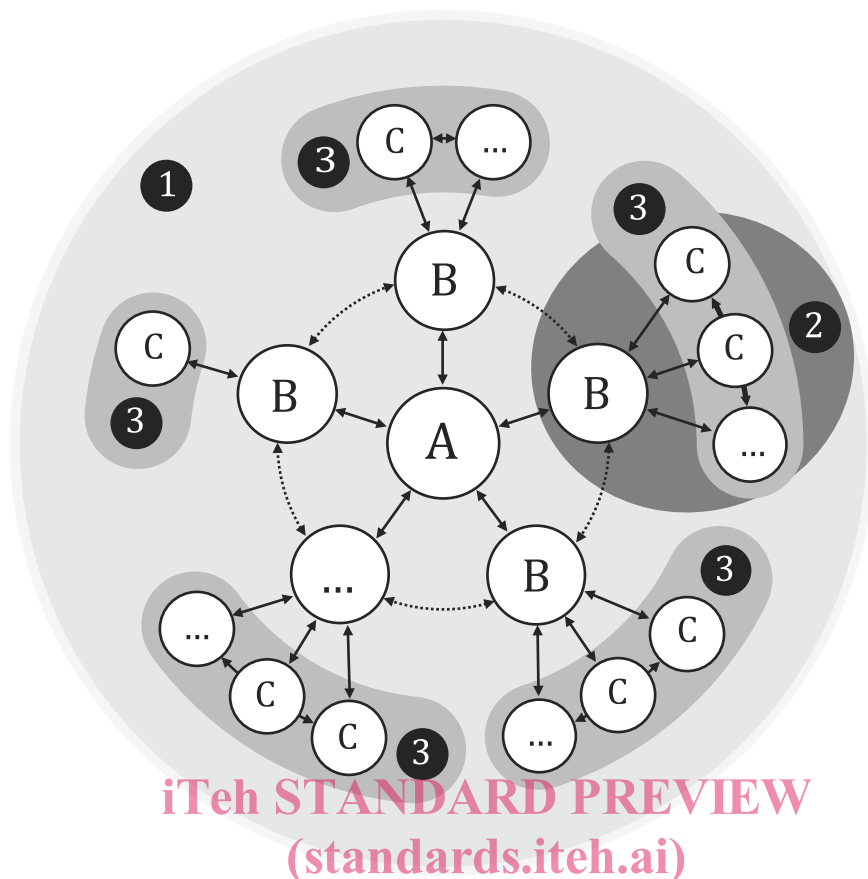

iTeh STANDARD PREVIEW
(standards.iteh.ai)

Key

- A appointing party
- B lead appointed party
- C appointed party
- ... variable amount
- 1 asset/facility management and operation team
- 2 illustration of a delivery team
- 3 task teams
- ↔ information requirements and information exchange
- ↔ information coordination between lead appointed parties if required by appointing party

ISO 19650-3:2020
<https://standards.iteh.ai/catalog/standards/sist/21b02de5-11d8-4e50-aceb-baa4c2b8a082/iso-19650-3-2020>

Figure 3 — Interface between parties and teams for the purpose of information management

Organization and digitization of information about buildings and civil engineering works, including building information modelling (BIM) — Information management using building information modelling —

Part 3: Operational phase of the assets

1 Scope

This document specifies requirements for information management, in the form of a management process, within the context of the operational phase of assets and the exchanges of information within it, using building information modelling.

This document can be applied to all types of assets and by organizations of all types and sizes involved in the operational phase of assets.

The requirements in this document can be achieved through direct actions carried out by the organization in question or can be delegated to another party.

2 Normative references

The following documents are referred to in the text in such a way that some or all of their content constitutes requirements of this document. For dated references, only the edition cited applies. For undated references, the latest edition of the referenced document (including any amendments) applies.

ISO 12006-2, *Building construction — Organization of information about construction works — Part 2: Framework for classification*

ISO 19650-1:2018, *Organization and digitization of information about buildings and civil engineering works, including building information modelling (BIM) — Information management using building information modelling — Part 1: Concepts and principles*

ISO 19650-2, *Organization and digitization of information about buildings and civil engineering works, including building information modelling (BIM) — Information management using building information modelling — Part 2: Delivery phase of the assets*

ISO 19650-5, *Organization and digitization of information about buildings and civil engineering works, including building information modelling (BIM) — Information management using building information modelling — Part 5: Security-minded approach to information management*

3 Terms, definitions, and symbols

3.1 Terms and definitions

For the purposes of this document, the terms and definitions given in ISO 19650-1 and the following apply.

ISO and IEC maintain terminological databases for use in standardization at the following addresses:

— ISO Online browsing platform: available at <https://www.iso.org/obp>

— IEC Electropedia: available at <http://www.electropedia.org/>

**3.1.1
asset management**

coordinated activity of an organization to realize value from assets

Note 1 to entry: Realization of value will normally involve a balancing of costs, risks, opportunities and performance benefits.

Note 2 to entry: Activity can also refer to the application of the elements of the asset management system.

Note 3 to entry: The term “activity” has a broad meaning and can include, for example, the approach, the planning, the execution and implementation of a plan.

[SOURCE: ISO 55000:2014, 3.3.1, modified — In Note 3 to entry, "the plans and their implementation" have been replaced by "the execution and implementation of a plan".]

**3.1.2
facility management
facilities management**

organizational function which integrates people, place and process within the built environment with the purpose of improving the quality of life of people and the productivity of the core business

[SOURCE: ISO 41011:2017, 3.1.1, modified — The abbreviated term "FM" has been removed.]

3.2 Symbols for process diagrams



start



trigger event



end



collapsed sub-process



decision

iTeh STANDARD PREVIEW
(standards.iteh.ai)

<https://standards.iteh.ai/catalog/standards/sist/21b02de5-11d8-4e50-aceb-baa4c2b8a082/iso-19650-3-2020>

NOTE The symbols used within this document have been adapted from symbols defined within ISO/IEC 19510.

4 Information management associated with the operational phase of assets

4.1 Information management process associated with the operational phase of assets

The information management process (Figure 4) shall be applied throughout the operational phase of each asset identified through the use of 5.1.3, and in the case of an existing asset shall be applied to all legacy information relating to that asset.

The information management process shall operate within or link with such enterprise systems or organizational functions as necessary to optimize its implementation.

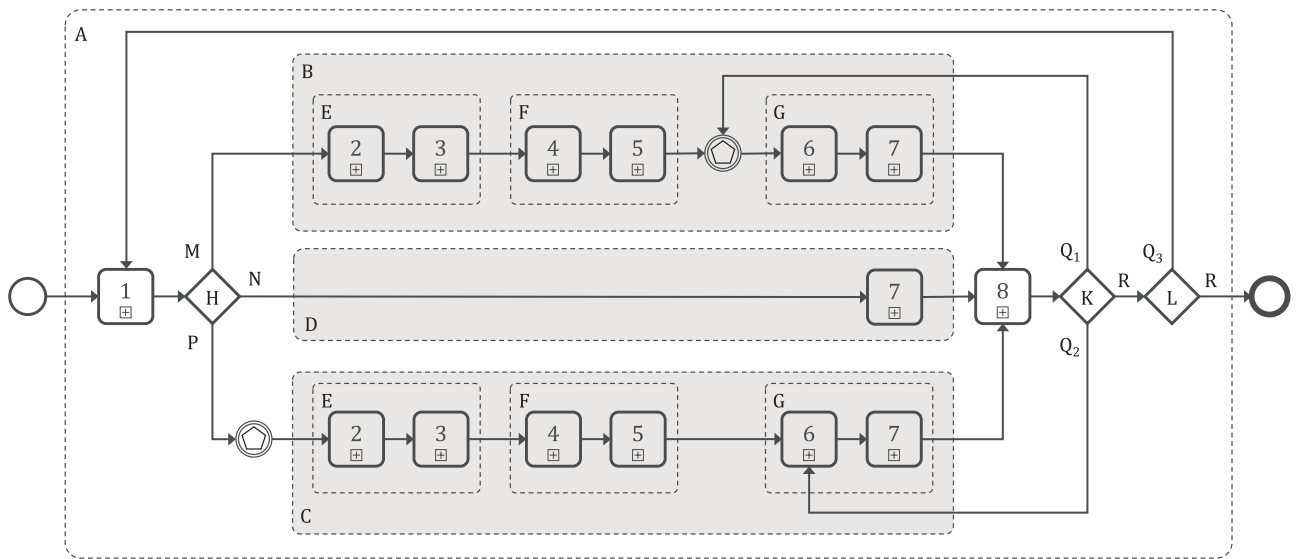

Key

Information management activities	Activity groupings	Decision points, questions and actions
1 assessment and need	A activities undertaken during the operational phase of assets	H type of trigger event providing information
2 invitation to tender/request to provide service	B activities undertaken for each appointment made before trigger event	K continuation of the appointment
3 response to invitation to tender/request to provide service	C activities undertaken for each appointment made after trigger event or delivery phase using ISO 19650-2	L continuation of this information management process
4 appointment	D activities undertaken when acquiring an asset	M via an appointment made before a trigger event
5 mobilization	E activities undertaken during the procurement stage (of each appointment)	N received from another appointing party/asset owner
6 production of information	F activities undertaken during the information planning stage (of each appointment)	P via an appointment made after a trigger event or delivery phase using ISO 19650-2
7 information model acceptance by appointing party	G activities undertaken during the information production stage (of each appointment)	Q ₁ yes — lead appointed party waits for next trigger event
8 AIM aggregation		Q ₂ yes — lead appointed party progresses to next delivery milestone
		Q ₃ yes — appointing party still has responsibility for the asset
		R no

NOTE 1 This process is intended to reduce the quantity of information to be reconciled at step 8 and reduces the effort of doing so.

NOTE 2 There can be several lead appointed parties responding to the same trigger event — see A.3 for examples of trigger events.

NOTE 3 Activities identified by C can apply during the operational or the delivery phases of the lifecycle. Activities identified by B and D apply during the operational phase of the lifecycle.

NOTE 4 Sub-processes within the information management activities 1 to 8 are shown in Figures 5 to 12.

Figure 4 — Information management process to support the operational phase of assets