

---

---

**Internal combustion engines — Piston  
pins —**

**Part 1:  
General specifications**

*Moteurs à combustion interne — Axes de pistons —*

*Partie 1: Spécifications générales*

<https://standards.iteh.ai>  
**Document Preview**

[ISO 18669-1:2021](https://standards.iteh.ai/catalog/standards/iso/f72bbda3-569b-4c9d-ab80-a1dec3a3b409/iso-18669-1-2021)

<https://standards.iteh.ai/catalog/standards/iso/f72bbda3-569b-4c9d-ab80-a1dec3a3b409/iso-18669-1-2021>



iTeh Standards  
(<https://standards.iteh.ai>)  
Document Preview

[ISO 18669-1:2021](https://standards.iteh.ai/catalog/standards/iso/f72bbda3-569b-4c9d-ab80-a1dec3a3b409/iso-18669-1-2021)

<https://standards.iteh.ai/catalog/standards/iso/f72bbda3-569b-4c9d-ab80-a1dec3a3b409/iso-18669-1-2021>



**COPYRIGHT PROTECTED DOCUMENT**

© ISO 2021

All rights reserved. Unless otherwise specified, or required in the context of its implementation, no part of this publication may be reproduced or utilized otherwise in any form or by any means, electronic or mechanical, including photocopying, or posting on the internet or an intranet, without prior written permission. Permission can be requested from either ISO at the address below or ISO's member body in the country of the requester.

ISO copyright office  
CP 401 • Ch. de Blandonnet 8  
CH-1214 Vernier, Geneva  
Phone: +41 22 749 01 11  
Email: [copyright@iso.org](mailto:copyright@iso.org)  
Website: [www.iso.org](http://www.iso.org)

Published in Switzerland

# Contents

Page

<b>Foreword</b> .....	<b>v</b>
<b>1 Scope</b> .....	<b>1</b>
<b>2 Normative references</b> .....	<b>1</b>
<b>3 Terms and definitions</b> .....	<b>1</b>
3.1 General.....	1
3.2 Geometrical and manufacturing features of piston pins.....	1
3.2.1 Bore types.....	1
3.2.2 Outside-edge configurations.....	2
3.2.3 Other features.....	3
<b>4 Symbols</b> .....	<b>3</b>
<b>5 Nomenclature</b> .....	<b>4</b>
5.1 Outside, inside and end features.....	4
5.2 Outside edge and inside chamfer configurations.....	6
5.2.1 Chamfered outside-edge configuration.....	6
5.2.2 Double-chamfered outside-edge configuration.....	6
5.2.3 Radiused outside-edge configuration.....	7
5.2.4 Chamfer-locking outside-edge configuration.....	7
5.3 Outside-edge drop-off configuration.....	8
<b>6 Codes</b> .....	<b>9</b>
<b>7 Designation of piston pins</b> .....	<b>10</b>
7.1 Designation elements and order.....	10
7.1.1 Mandatory elements.....	10
7.1.2 Additional elements.....	10
7.2 Designation examples.....	10
<b>8 Piston pin types, dimensions and tolerances</b> .....	<b>11</b>
8.1 Manufacturing types.....	11
8.2 Dimensions and tolerances.....	11
8.2.1 Outside diameter and form and location tolerances.....	11
8.2.2 Inside diameter tolerance.....	13
8.2.3 Length ( $l_1$ ) and gauge length ( $l_5$ ) tolerances.....	13
8.2.4 Outside-edge form.....	14
8.2.5 Inside-edge profile.....	15
8.2.6 Tapered bore dimensions.....	16
8.2.7 Centre-web dimensions (see <a href="#">Figure 17</a> ).....	18
<b>9 Material and heat treatment</b> .....	<b>18</b>
9.1 Type of material.....	18
9.2 Core hardness / core strength.....	19
9.3 Carburised and nitrided case depth.....	20
9.4 Surface hardness.....	21
9.5 Volume change.....	21
<b>10 Common features</b> .....	<b>22</b>
10.1 Roughness of surfaces.....	22
10.1.1 Roughness of machined surfaces.....	22
10.1.2 Roughness of coated surfaces.....	22
10.1.3 Roughness of extruded and seamless drawn bore surfaces.....	23
10.2 Marking of piston pins.....	23
10.3 Miscellaneous.....	23
10.3.1 Cleanliness.....	23
10.3.2 Corrosion protection.....	23
10.3.3 Residual magnetism.....	23
10.3.4 Packaging.....	23

<b>11</b>	<b>Quality requirements</b>	<b>24</b>
11.1	Material characteristics	24
11.1.1	Decarburisation	24
11.1.2	Cementite network	24
11.1.3	Nitride coating	24
11.1.4	Grinder burn	24
11.2	Material defects	24
11.2.1	Cracks	24
11.2.2	Forming streaks	24
11.3	Visual defects	25
	<b>Bibliography</b>	<b>26</b>

**iTeh Standards**  
**(<https://standards.iteh.ai>)**  
**Document Preview**

[ISO 18669-1:2021](https://standards.iteh.ai/catalog/standards/iso/f72bbda3-569b-4c9d-ab80-a1dec3a3b409/iso-18669-1-2021)

<https://standards.iteh.ai/catalog/standards/iso/f72bbda3-569b-4c9d-ab80-a1dec3a3b409/iso-18669-1-2021>

## Foreword

ISO (the International Organization for Standardization) is a worldwide federation of national standards bodies (ISO member bodies). The work of preparing International Standards is normally carried out through ISO technical committees. Each member body interested in a subject for which a technical committee has been established has the right to be represented on that committee. International organizations, governmental and non-governmental, in liaison with ISO, also take part in the work. ISO collaborates closely with the International Electrotechnical Commission (IEC) on all matters of electrotechnical standardization.

The procedures used to develop this document and those intended for its further maintenance are described in the ISO/IEC Directives, Part 1. In particular, the different approval criteria needed for the different types of ISO documents should be noted. This document was drafted in accordance with the editorial rules of the ISO/IEC Directives, Part 2 (see [www.iso.org/directives](http://www.iso.org/directives)).

Attention is drawn to the possibility that some of the elements of this document may be the subject of patent rights. ISO shall not be held responsible for identifying any or all such patent rights. Details of any patent rights identified during the development of the document will be in the Introduction and/or on the ISO list of patent declarations received (see [www.iso.org/patents](http://www.iso.org/patents)).

Any trade name used in this document is information given for the convenience of users and does not constitute an endorsement.

For an explanation of the voluntary nature of standards, the meaning of ISO specific terms and expressions related to conformity assessment, as well as information about ISO's adherence to the World Trade Organization (WTO) principles in the Technical Barriers to Trade (TBT), see [www.iso.org/iso/foreword.html](http://www.iso.org/iso/foreword.html).

This document was prepared by Technical Committee ISO/TC 22, *Road vehicles*, Subcommittee SC 34, *Propulsion, powertrain and powertrain fluids*.

This third edition cancels and replaces the second edition (ISO 18669-1:2013), which has been technically revised.

The main changes compared to the previous edition are as follows:

- [Clause 2](#) added,
- [Table 4](#) “Waviness” added,
- [Table 18](#) “Roughness machined surfaces” changed,
- Subclause [10.1.2](#) “Roughness of coated surfaces” added,
- [Table 20](#) “Material defects” changed,
- [Table 21](#) “Visual defects” changed,
- editorial changes.

A list of all parts in the ISO 18669 series can be found on the ISO website.

Any feedback or questions on this document should be directed to the user's national standards body. A complete listing of these bodies can be found at [www.iso.org/members.html](http://www.iso.org/members.html).



# Internal combustion engines — Piston pins —

## Part 1: General specifications

### 1 Scope

This document specifies the essential dimensional characteristics of piston pins with a nominal outer diameter from 8 mm up to and including 100 mm, for reciprocating internal combustion engines for road vehicles and other applications. In certain applications, except road vehicles, and provided that mutual agreement is made between the customer and the manufacturer, this document can be used with suitable modifications.

In addition, it establishes a vocabulary, a pin-type classification, material description based on mechanical properties, common features and quality requirements.

The use of this document can require a manufacturer and customer statistical process control agreement.

### 2 Normative references

There are no normative references in this document.

### 3 Terms and definitions

For the purposes of this document, the following terms and definitions apply.

ISO and IEC maintain terminological databases for use in standardization at the following addresses:

- ISO Online browsing platform: available at <https://www.iso.org/obp>
- IEC Electropedia: available at <https://www.electropedia.org/>

#### 3.1 General

##### 3.1.1

##### **piston pin**

precision cylindrical component that connects the piston to the connecting rod and has a smooth hard peripheral surface

#### 3.2 Geometrical and manufacturing features of piston pins

##### 3.2.1 Bore types

##### 3.2.1.1

##### **cylindrical bore**

pin having a straight cylindrical bore

**3.2.1.2**

**centre web**

pin bore with centre web

pin inside diameter formed symmetrically from each end leaving a web in the pin centre

Note 1 to entry: The web is subsequently removed leaving a step as shown in [Figure 3](#).

**3.2.1.3**

**tapered bore**

pin with conical-shaped inside diameter near the ends that reduces the weight of the *piston pin* ([3.1.1](#))

**3.2.1.4**

**machined bore**

pin with inside diameter produced solely by machining

**3.2.1.5**

**seamless drawn tube**

hollow steel product which does not contain any line junctures resulting from the method of manufacture

**3.2.1.6**

**end web**

pin bore with end web

pin inner diameter formed from one end leaving a web near the opposite end

Note 1 to entry: The web is punched out. The pin is then drawn over a mandrel and a forming line may result as shown in [Figure 4](#).

**3.2.2 Outside-edge configurations**

**3.2.2.1**

**chamfer**

outside-edge bevelled feature that is sometimes used to mate with a round retainer ring

Note 1 to entry: Referred to as “locking chamfer” when a round wire retainer ring is located on the chamfer angle and used to secure the pin in the piston.

**3.2.2.2**

**outside-edge form angle**

$\delta$

region of outside-edge form that provides a smooth transition to the peripheral surface to facilitate ease of assembly

**3.2.2.3**

**outside-edge form angle end face**

$\gamma$

region of outside-edge form that provides a smooth transition to the end face

**3.2.2.4**

**drop-off**

non-functional machining feature that creates a transition between the outside edge and the peripheral surface

Note 1 to entry: See [Figure 12](#).

**3.2.2.5**

**inside-edge chamfer**

bevelled edge between the bore surface and the end faces of the *piston pin* ([3.1.1](#))



**3.2.2.6****gauge point**

locating point on the pin outside-edge *chamfer* (3.2.2.1) from where the gauge diameter ( $d_5$ ) and gauge length ( $l_5$ ) are measured

**3.2.3 Other features****3.2.3.1****volume change**

change detected as a permanent outside-diameter dimensional deviation at reference temperature after being heated to a test temperature for a specified period of time

**3.2.3.2****slag line**

linear flaw of non-metallic inclusions

**4 Symbols**

Symbol	Description
$a$	Wall thickness
$b$	Outside-edge drop-off length
$c$	Outside-edge drop-off height
$d_1$	Outside diameter
$d_2$	Inside diameter
$d_3$	Tapered bore diameter
$d_4$	Centre-web diameter
$d_5$	Gauge diameter
$d_6$	End face diameter
$e$	Tapered bore runout
$f$	Outside-edge length
$g$	Outside-edge chamfer length
$H_s$	Limit hardness
$h_1$	End face concavity
$h_2$	End face step
$k$	Tapered bore relief
$l_1$	Length
$l_3$	Tapered bore length
$l_4$	Centre-web length
$l_5$	Gauge length
$r$	Outside-edge radius
$R_m$	Core strength
$s$	End face runout
$t_1$	Inside-edge chamfer length
$t_2$	Outside-edge form length
$\alpha$	Tapered bore angle
$\beta$	Outside-edge chamfer angle
$\gamma$	Outside-edge form angle end face
$\delta$	Outside-edge form angle

## 5 Nomenclature

### 5.1 Outside, inside and end features

Terms commonly used to describe pins with a cylindrical bore are shown in [Figure 1](#).

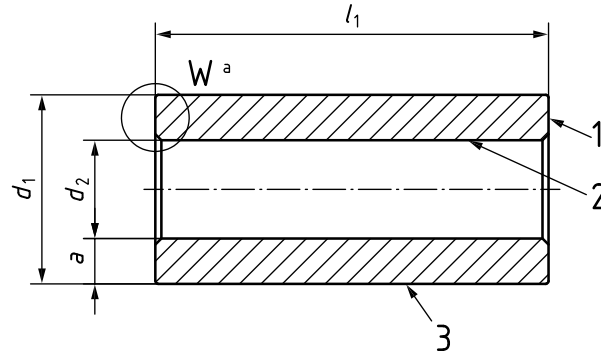

**Key**

- 1 end face
- 2 bore surface
- 3 peripheral surface
- $d_1$  outside diameter
- $d_2$  inside diameter
- $l_1$  length
- $a$  wall thickness
- <sup>a</sup> For detail W see [Figure 2](#).

iTeh Standards  
 (https://standards.itih.ai)  
 Document Preview

**Figure 1 — Pin with cylindrical bore**

Terms commonly used to describe end face concavity are shown in [Figure 2a](#)).  
<https://standards.iteh.ai/catalog/standards/iso/18669-1/2021-05/98746934-8866-41dec3a3b409/iso-18669-1-2021>

Terms commonly used to describe end face step are shown in [Figure 2b](#)).

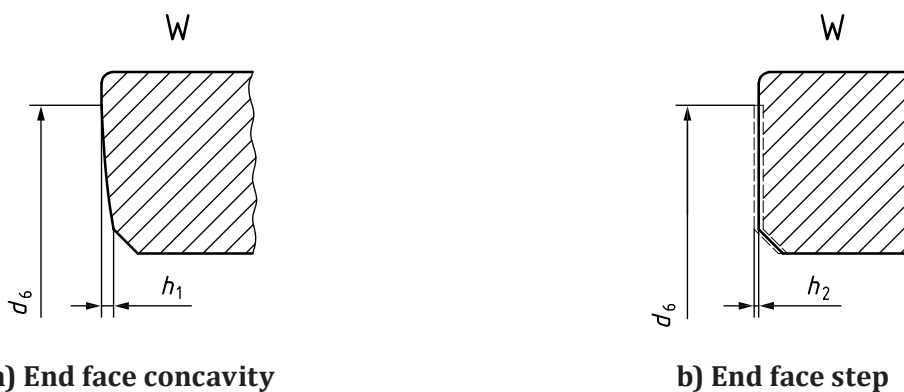

**Key**

- $h_1$  end face concavity
  - $h_2$  end face step
  - $d_6$  end face diameter
- End face concavity and end face step are not recommended for end face locking.

**Figure 2 — Detail W of [Figure 1](#)**

Terms commonly used to describe pins with a centre web are shown in [Figure 3](#).

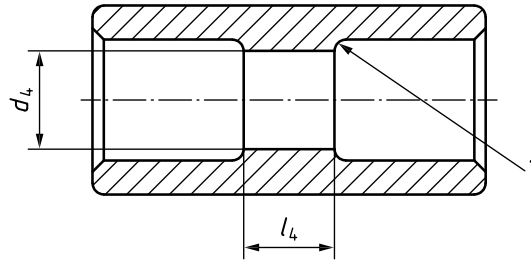

**Key**

- 1 centre-web radius
- $l_4$  centre-web length
- $d_4$  centre-web diameter

**Figure 3 — Pin with cold-formed centre web**

Terms commonly used to describe pins with a cold-formed end web are shown in [Figure 4](#).

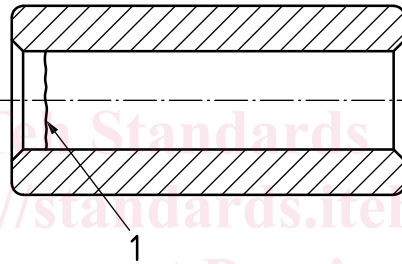

**Key**

- 1 end-web forming line

**Figure 4 — Pin with cold-formed end web**

Terms commonly used to describe pins with a tapered bore are shown in [Figure 5](#).

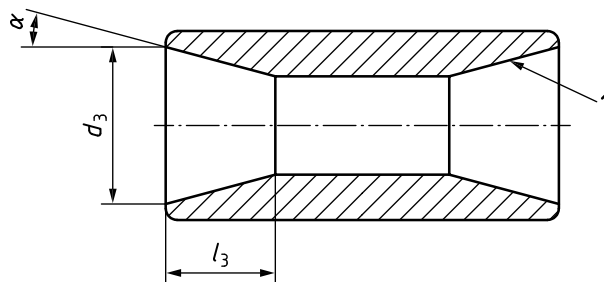

**Key**

- 1 tapered bore surface
- $\alpha$  tapered bore angle
- $d_3$  tapered bore diameter
- $l_3$  tapered bore length

**Figure 5 — Pin with tapered bore**