**Fire-resistance tests — Elements of
building construction —**

Part 2:
**Requirements and recommendations
for measuring furnace exposure on
test samples**

iTen Standards
(<https://standards.iteh.ai>)
Document Preview

[ISO 834-2:2019](https://standards.iteh.ai/catalog/standards/iso/0b25a466-6f63-406f-878e-cd520baabc37/iso-834-2-2019)

<https://standards.iteh.ai/catalog/standards/iso/0b25a466-6f63-406f-878e-cd520baabc37/iso-834-2-2019>



iTeh Standards
(<https://standards.iteh.ai>)
Document Preview

[ISO 834-2:2019](https://standards.iteh.ai/catalog/standards/iso/0b25a466-6f63-406f-878e-cd520baabc37/iso-834-2-2019)

<https://standards.iteh.ai/catalog/standards/iso/0b25a466-6f63-406f-878e-cd520baabc37/iso-834-2-2019>



COPYRIGHT PROTECTED DOCUMENT

© ISO 2019

All rights reserved. Unless otherwise specified, or required in the context of its implementation, no part of this publication may be reproduced or utilized otherwise in any form or by any means, electronic or mechanical, including photocopying, or posting on the internet or an intranet, without prior written permission. Permission can be requested from either ISO at the address below or ISO's member body in the country of the requester.

ISO copyright office
CP 401 • Ch. de Blandonnet 8
CH-1214 Vernier, Geneva
Phone: +41 22 749 01 11
Fax: +41 22 749 09 47
Email: copyright@iso.org
Website: www.iso.org

Published in Switzerland

Contents

	Page
Foreword	iv
Introduction	v
1 Scope	1
2 Normative references	1
3 Terms and definitions	1
4 Test equipment	1
4.1 Supporting construction.....	1
4.2 Instrumentation.....	6
5 Test method	11
6 Report	11
Annex A (informative) Commentary	13
Bibliography	14

iTeh Standards
(<https://standards.itih.ai>)
Document Preview

[ISO 834-2:2019](https://standards.itih.ai/catalog/standards/iso/0b25a466-6f63-406f-878e-cd520baabc37/iso-834-2-2019)

<https://standards.itih.ai/catalog/standards/iso/0b25a466-6f63-406f-878e-cd520baabc37/iso-834-2-2019>

Foreword

ISO (the International Organization for Standardization) is a worldwide federation of national standards bodies (ISO member bodies). The work of preparing International Standards is normally carried out through ISO technical committees. Each member body interested in a subject for which a technical committee has been established has the right to be represented on that committee. International organizations, governmental and non-governmental, in liaison with ISO, also take part in the work. ISO collaborates closely with the International Electrotechnical Commission (IEC) on all matters of electrotechnical standardization.

The procedures used to develop this document and those intended for its further maintenance are described in the ISO/IEC Directives, Part 1. In particular, the different approval criteria needed for the different types of ISO documents should be noted. This document was drafted in accordance with the editorial rules of the ISO/IEC Directives, Part 2 (see www.iso.org/directives).

Attention is drawn to the possibility that some of the elements of this document may be the subject of patent rights. ISO shall not be held responsible for identifying any or all such patent rights. Details of any patent rights identified during the development of the document will be in the Introduction and/or on the ISO list of patent declarations received (see www.iso.org/patents).

Any trade name used in this document is information given for the convenience of users and does not constitute an endorsement.

For an explanation of the voluntary nature of standards, the meaning of ISO specific terms and expressions related to conformity assessment, as well as information about ISO's adherence to the World Trade Organization (WTO) principles in the Technical Barriers to Trade (TBT) see www.iso.org/iso/foreword.html.

This document was prepared by Technical Committee ISO/TC 92, *Fire safety*, Subcommittee SC 2, *Fire containment*.

This first edition cancels and replaces ISO/TR 834-2:2009, which has been technically revised.

A list of all parts in the ISO 834 series can be found on the ISO website.

Any feedback or questions on this document should be directed to the user's national standards body. A complete listing of these bodies can be found at www.iso.org/members.html.

Introduction

The purpose of this document is to describe a procedure to measure the exposure of a test sample to a furnace during a test conducted in accordance with ISO 834 (all parts). The furnace exposure is determined by measuring temperature, air velocity and oxygen concentration at various locations. The procedure includes the use of low-cost, readily available, lightweight materials to represent the test sample. The recommended materials minimize the influence of variable moisture content among samples.

iTeh Standards
(<https://standards.iteh.ai>)
Document Preview

[ISO 834-2:2019](https://standards.iteh.ai/catalog/standards/iso/0b25a466-6f63-406f-878e-cd520baabc37/iso-834-2-2019)

<https://standards.iteh.ai/catalog/standards/iso/0b25a466-6f63-406f-878e-cd520baabc37/iso-834-2-2019>

Fire-resistance tests — Elements of building construction —

Part 2: Requirements and recommendations for measuring furnace exposure on test samples

1 Scope

This document establishes general principles for measuring the uniformity of furnace exposure of samples tested in accordance with the requirements of ISO 834-1. This document specifies the type and location of instrumentation used to measure the temperature, velocity and oxygen content near the surface of simulated test samples. The surface of the simulated sample facing the furnace is gypsum board secured to cold-formed steel supports.

This document does not include requirements for furnace performance. An intended use of data generated by the application of this document and the rationale for the instrumentation described in this document are contained in the informative [Annex A](#).

2 Normative references

The following documents are referred to in the text in such a way that some or all of their content constitutes requirements of this document. For dated references, only the edition cited applies. For undated references, the latest edition of the referenced document (including any amendments) applies.

ISO 834-1, *Fire-resistance tests — Elements of building construction — Part 1: General requirements*

<https://standards.iteh.ai/catalog/standards/iso/0b25a466-6f63-406f-878e-cd520baabc37/iso-834-2-2019>

3 Terms and definitions

For the purposes of this document, the following terms and definitions apply.

ISO and IEC maintain terminological databases for use in standardization at the following addresses:

- ISO Online browsing platform: available at <https://www.iso.org/obp>
- IEC Electropedia: available at <http://www.electropedia.org/>

3.1

effective area of furnace opening

furnace opening within the boundaries of the monitoring instrumentation

4 Test equipment

4.1 Supporting construction

4.1.1 The supporting construction shall consist of cold-formed steel supports faced with two layers of gypsum board a minimum of 15 mm thick intended for use in fire-barrier assemblies on the side facing the furnace and with a single-layer structural panel a minimum of 15 mm thick on the side facing away from the furnace.

NOTE 1 Some examples of gypsum boards used in fire barrier assemblies include Type X by ASTM C1396, Type F by EN 520 and as described in JIS A 6901.

NOTE 2 Cement boards, gypsum boards, plywood and oriented strand boards are considered typical structural panels.

4.1.2 Construction details with respect to the location of the support channels, gypsum board and the structural panels are shown in Figures 1 to 6. Figures 1 to 3 apply to horizontal supporting constructions. Figures 4 to 6 apply to vertical supporting constructions.

4.1.2.1 The construction details assume a horizontal furnace opening of 3 m by 4 m and a vertical furnace opening of 3 m by 3 m. Modifications to dimensions for other furnace opening dimensions and allowances for compatibility with locally available materials and practices are acceptable.

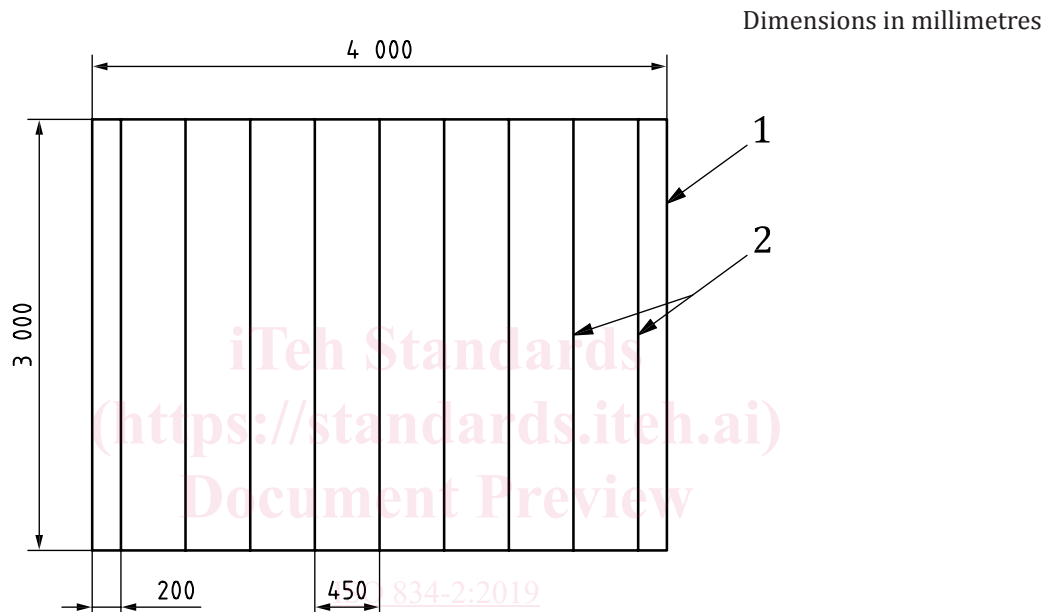

<https://standards.itih.ai/catalog/standards/iso/0b25a466-6f63-406f-878e-cd520baabc37/iso-834-2-2019>

Key

- 1 perimeter of supporting construction
- 2 support channels, nine, spaced 450 mm on centre

Figure 1 — Details of horizontal supporting construction — Layout of support channels

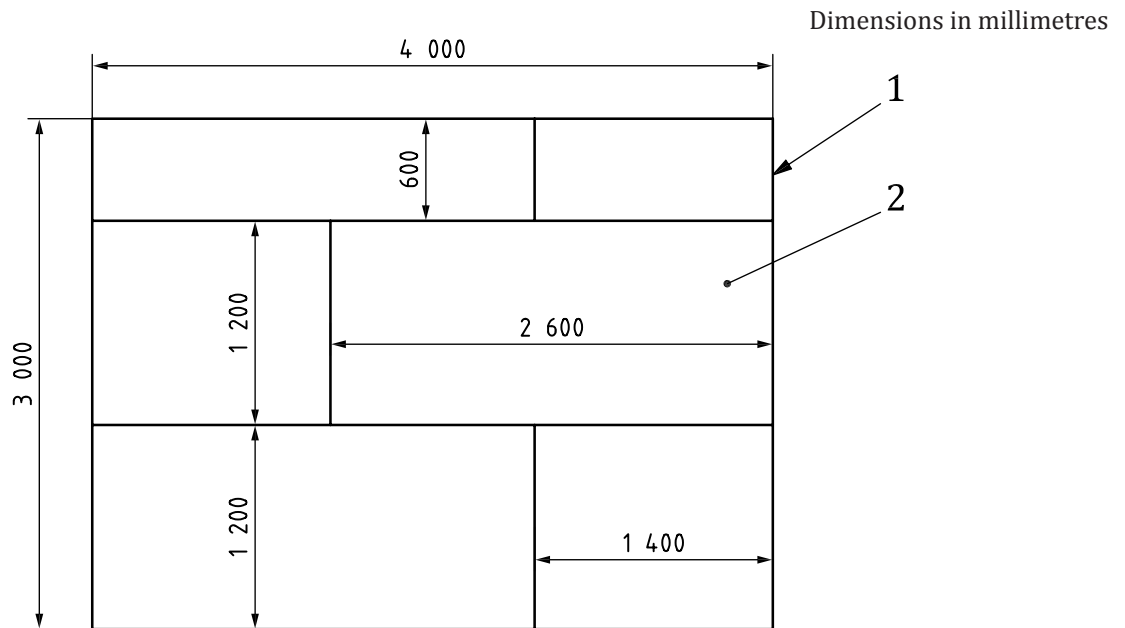

Key

- 1 perimeter of supporting construction
- 2 inner (first) layer of gypsum board or structural panels on unexposed surface

Figure 2 — Details of horizontal supporting construction — Layout of inner layer of gypsum board and structural panels

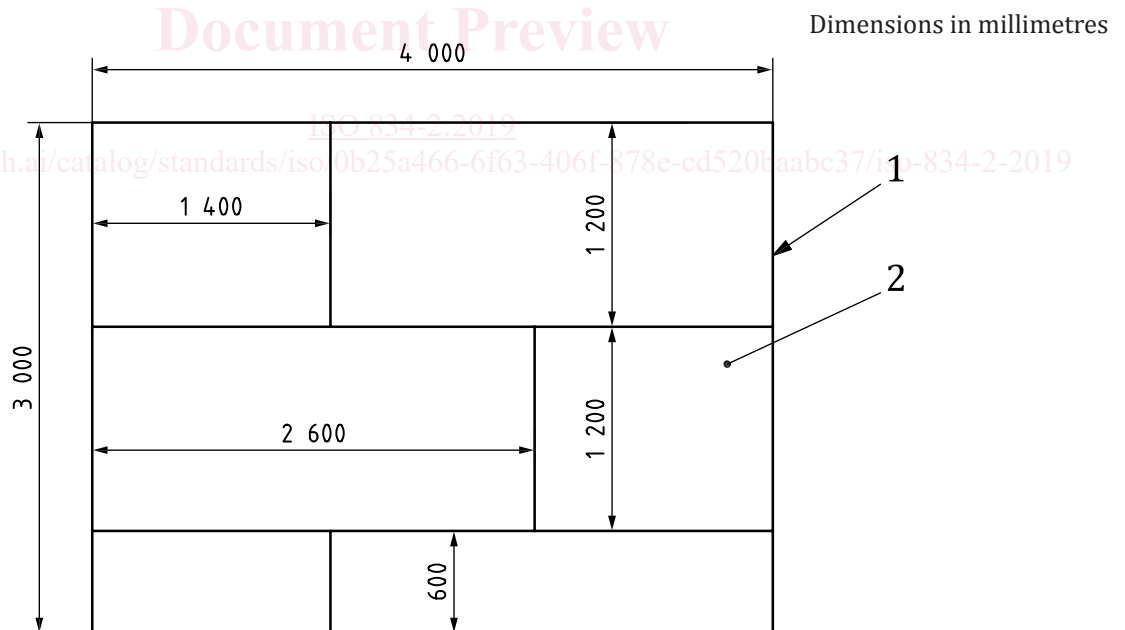

Key

- 1 perimeter of supporting construction
- 2 outer (second) layer of gypsum board

Figure 3 — Details of horizontal supporting construction — Layout of outer layer of gypsum board

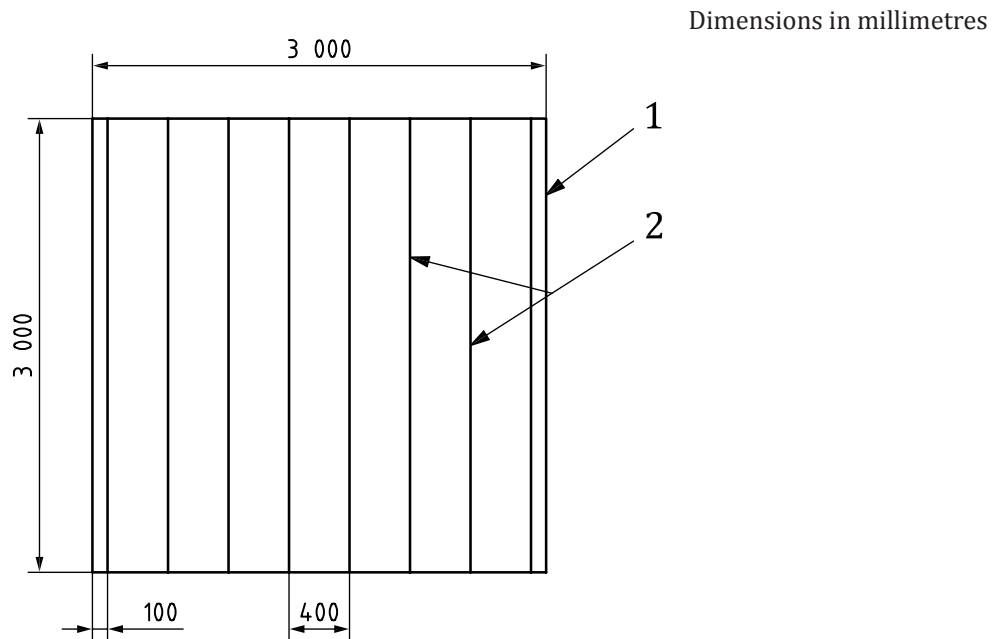

Key

- 1 perimeter of supporting construction
- 2 support channels, eight, spaced 400 mm on centre

Figure 4 — Details of vertical supporting construction — Layout of support channels

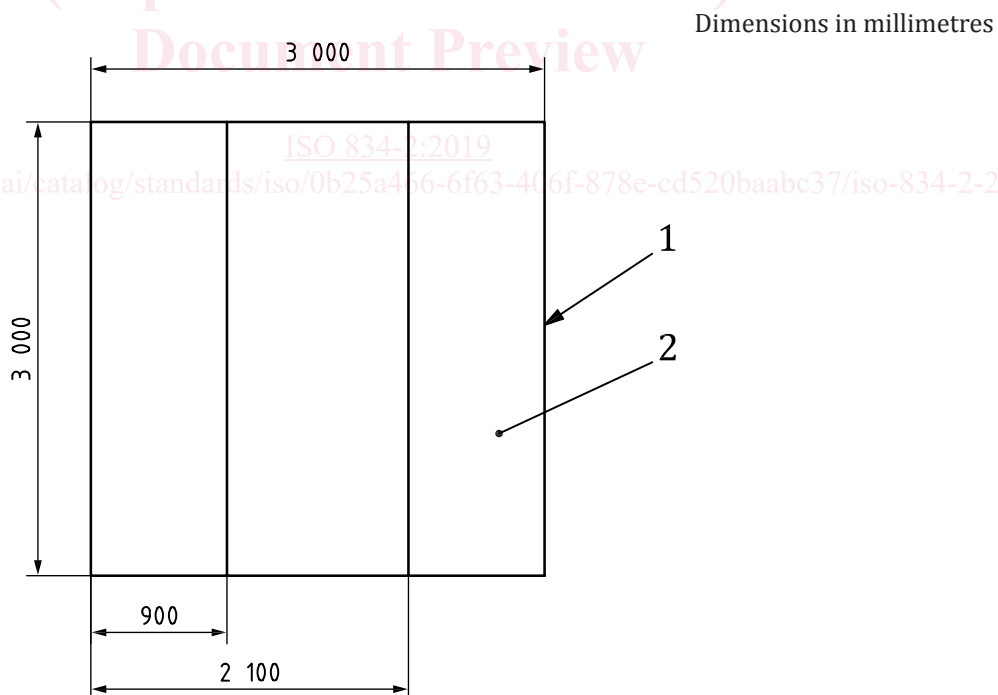

Key

- 1 perimeter of supporting construction
- 2 inner (first) layer of gypsum board or structural panels on unexposed surface

Figure 5 — Details of vertical supporting construction — Layout of inner layer of gypsum board and structural panels