



Designation: D6371 – 05 (Reapproved 2010)

## Standard Test Method for Cold Filter Plugging Point of Diesel and Heating Fuels<sup>1</sup>

This standard is issued under the fixed designation D6371; the number immediately following the designation indicates the year of original adoption or, in the case of revision, the year of last revision. A number in parentheses indicates the year of last reapproval. A superscript epsilon ( $\epsilon$ ) indicates an editorial change since the last revision or reapproval.

### 1. Scope

1.1 This test method covers the determination of the cold filter plugging point (CFPP) temperature of diesel and domestic heating fuels using either manual or automated apparatus.

NOTE 1—This test method is technically equivalent to test methods IP 309 and EN 116.

1.2 The manual apparatus and automated apparatus are both suitable for referee purposes.

1.3 This test method is applicable to distillate fuels, including those containing a flow-improving or other additive, intended for use in diesel engines and domestic heating installations.

1.4 The values stated in SI units are to be regarded as standard. No other units of measurement are included in this standard.

1.5 **WARNING**—Mercury has been designated by many regulatory agencies as a hazardous material that can cause central nervous system, kidney and liver damage. Mercury, or its vapor, may be hazardous to health and corrosive to materials. Caution should be taken when handling mercury and mercury containing products. See the applicable product Material Safety Data Sheet (MSDS) for details and EPA's website—<http://www.epa.gov/mercury/faq.htm>—for additional information. Users should be aware that selling mercury and/or mercury containing products into your state or country may be prohibited by law.

1.6 *This standard does not purport to address all of the safety concerns, if any, associated with its use. It is the responsibility of the user of this standard to establish appropriate safety and health practices and determine the applicability of regulatory limitations prior to use.* For specific warning statements, see Section 7.

<sup>1</sup> This test method is under the jurisdiction of ASTM Committee D02 on Petroleum Products, Liquid Fuels, and Lubricants and is the direct responsibility of Subcommittee D02.07 on Flow Properties.

Current edition approved Aug. 1, 2010. Published November 2010. Originally approved in 1999. Last previous edition approved in 2005 as D6371-05. DOI: 10.1520/D6371-05R10.

### 2. Referenced Documents

#### 2.1 ASTM Standards:<sup>2</sup>

D2500 Test Method for Cloud Point of Petroleum Products  
D4057 Practice for Manual Sampling of Petroleum and Petroleum Products

D4177 Practice for Automatic Sampling of Petroleum and Petroleum Products

D5771 Test Method for Cloud Point of Petroleum Products (Optical Detection Stepped Cooling Method)

D5772 Test Method for Cloud Point of Petroleum Products (Linear Cooling Rate Method)

D5773 Test Method for Cloud Point of Petroleum Products (Constant Cooling Rate Method)

E1 Specification for ASTM Liquid-in-Glass Thermometers

#### 2.2 IP Standards:<sup>3</sup>

IP 309 Diesel and domestic heating fuels - Determination of cold filter plugging point  
Specifications for IP Standard Thermometers

#### 2.3 ISO Standards:<sup>4</sup>

IP 3310 Test sieves - Technical requirements and testing - Part 1: Metal cloth

#### 2.4 European Standards:<sup>5</sup>

EN 116 Diesel and domestic heating fuels - Determination of cold filter plugging point

<sup>2</sup> For referenced ASTM standards, visit the ASTM website, [www.astm.org](http://www.astm.org), or contact ASTM Customer Service at [service@astm.org](mailto:service@astm.org). For *Annual Book of ASTM Standards* volume information, refer to the standard's Document Summary page on the ASTM website.

<sup>3</sup> Available from Energy Institute, 61 New Cavendish St., London, WIG 7AR, U.K., <http://www.energyinst.org.uk>.

<sup>4</sup> Available from American National Standards Institute (ANSI), 25 W. 43rd St., 4th Floor, New York, NY 10036, <http://www.ansi.org>.

<sup>5</sup> Available from European Committee for Standardization (CEN), 36 rue de Stassart, B-1050, Brussels, Belgium, <http://www.cenorm.be>.

### 3. Terminology

#### 3.1 Definitions of Terms Specific to This Standard:

3.1.1 *certified reference material, n*—a stable petroleum product with a method-specific nominal CFPP value established by a method-specific interlaboratory study following RR:D02-1007<sup>6</sup> guidelines or ISO Guides 34 and 35.<sup>4</sup>

3.1.2 *cold filter plugging point, n*—highest temperature, expressed in multiples of 1°C, at which a given volume of fuel fails to pass through a standardized filtration device in a specified time when cooled under the conditions prescribed in this test method.

### 4. Summary of Test Method

4.1 A specimen of the sample is cooled under specified conditions and, at intervals of 1°C, is drawn into a pipet under a controlled vacuum through a standardized wire mesh filter. The procedure is repeated, as the specimen continues to cool, for each 1°C below the first test temperature. Testing is continued until the amount of wax crystals that have separated out of solution is sufficient to stop or slow down the flow so that the time taken to fill the pipet exceeds 60 s or the fuel fails to return completely to the test jar before the fuel has cooled by a further 1°C.

4.2 The indicated temperature at which the last filtration was commenced is recorded as the CFPP.

### 5. Significance and Use

5.1 The CFPP of a fuel is suitable for estimating the lowest temperature at which a fuel will give trouble-free flow in certain fuel systems.

5.2 In the case of diesel fuel used in European light duty trucks, the results are usually close to the temperature of failure in service except when the fuel system contains, for example, a paper filter installed in a location exposed to the weather or if the filter plugging temperature is more than 12°C below the cloud point value in accordance with Test Method D2500, D5771, D5772, or D5773. Domestic heating installations are usually less critical and often operate satisfactorily at temperatures somewhat lower than those indicated by the test results.

5.3 The difference in results obtained from the sample as received and after heat treatment at 45°C for 30 min can be used to investigate complaints of unsatisfactory performance under low temperature conditions.

### 6. Apparatus

#### 6.1 Manual Apparatus:

6.1.1 The apparatus, as detailed in 6.1.2 – 6.1.13, shall be arranged as shown in Fig. 1.

6.1.2 *Test Jar*, cylindrical, of clear glass, flat bottomed, with an internal diameter of  $31.5 \pm 0.5$  mm, a wall thickness of  $1.25 \pm 0.25$  mm and a height of  $120 \pm 5$  mm. The jar shall have a permanent mark at the  $45 \pm 1$  mL level.

NOTE 2—Test jars of the required dimensions may be obtained by

<sup>6</sup> Supporting data have been filed at ASTM International Headquarters and may be obtained by requesting Research Report RR:D02-1007.

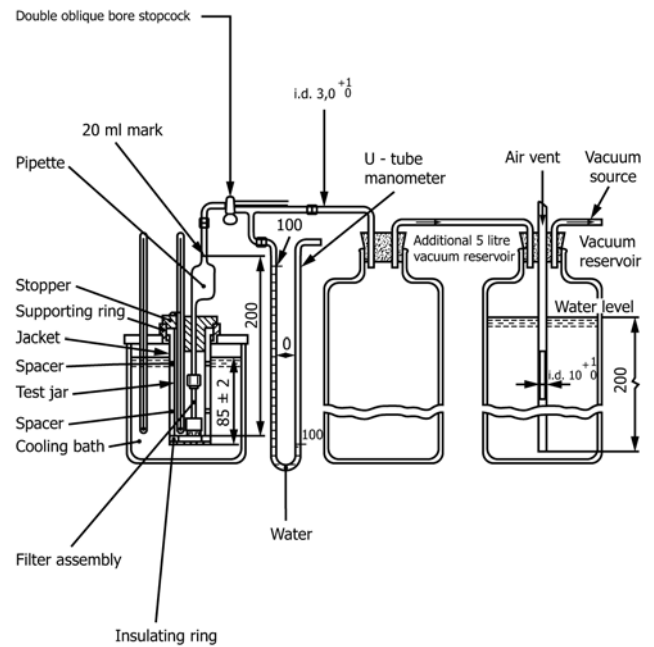

NOTE 1—All dimensions are in millimetres, and the comma (,) is used as the decimal point.

FIG. 1 Arrangement of Manual CFPP Apparatus

selection from jars conforming to Test Method D2500, which specifies a wider diameter tolerance.

6.1.3 *Jacket*, brass, watertight, cylindrical, flat bottomed, to be used as an air bath. It shall have an inside diameter of  $45 \pm 0.25$  mm, outside diameter of  $48 \pm 0.25$  mm, and a height of  $115 \pm 3$  mm (see Fig. 2).

6.1.4 *Insulating Ring*, made from oil-resistant plastics or other suitable material, to be placed in the bottom of the jacket (see 6.1.3) to provide insulation for the bottom of the test jar. It shall fit closely inside the jacket and have a thickness of  $6 + 0.3 - 0.0$  mm.

6.1.5 *Spacers* (two), approximately 5-mm thick, made of oil-resistant plastics or other suitable material, to be placed as shown in Fig. 1 around the test jar (see 6.1.2) to provide insulation for the test jar from the sides of the jacket. The spacers shall fit closely to the test jar and closely inside the jacket. The use of incomplete rings, each with a 2-mm circumferential gap, will accommodate variations in test jar diameter. The spacers and insulating ring may be made as a single part as shown in Fig. 3.

6.1.6 *Supporting Ring*, of oil resistant plastics or other suitable non-metallic, non-absorbent, oil-resistant material, used to suspend the jacket (see 6.1.3) in a stable and upright position in the cooling bath and to provide a concentric location for the stopper (see 6.1.7). A design is shown in Fig. 4 for guidance, but this design may be modified to suit the cooling bath.

6.1.7 *Stopper*, of oil-resistant plastics or other suitable nonmetallic, nonabsorbent, oil-resistant material, to fit the test jar and the support ring as shown in Fig. 5. It shall have three holes to accommodate the pipet (see 6.1.8) and the thermometer (see 6.1.9) and to allow venting of the system. If necessary, when using the high-range thermometer (see 6.1.9), the upper

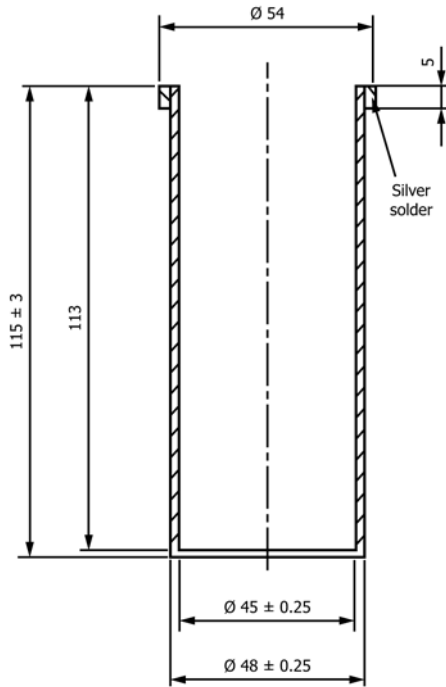

NOTE 1—All dimensions are in millimetres, and the comma (,) is used as the decimal point.

FIG. 2 Watertight Brass Jacket

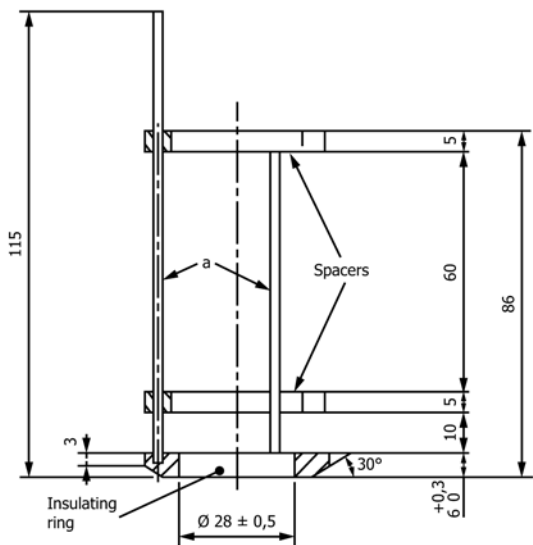
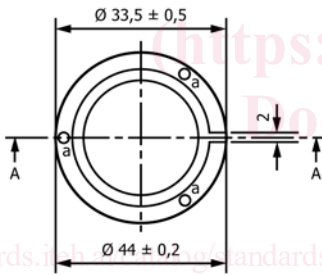

NOTE 1—All dimensions are in millimetres, and the comma (,) is used as the decimal point.

FIG. 3 Spacers

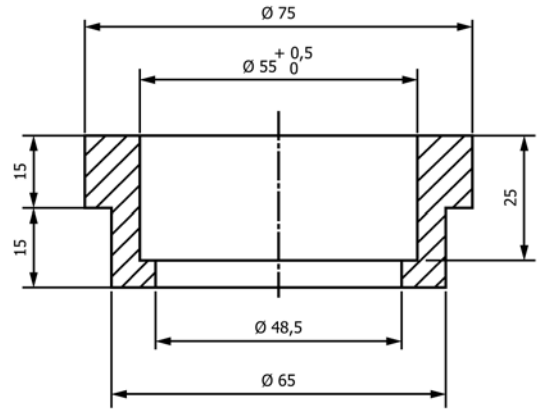

NOTE 1—All dimensions are in millimetres, and the comma (,) is used as the decimal point.

FIG. 4 Supporting Ring

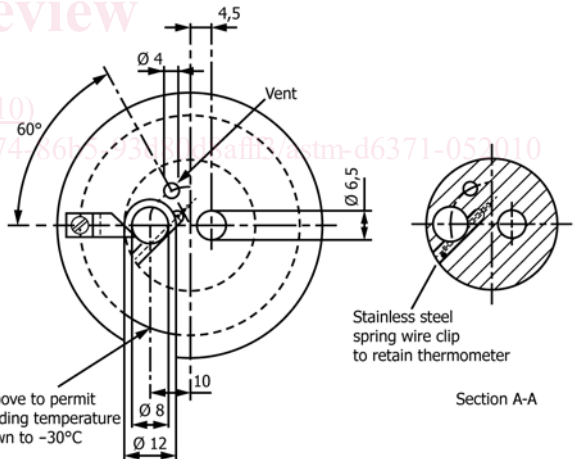
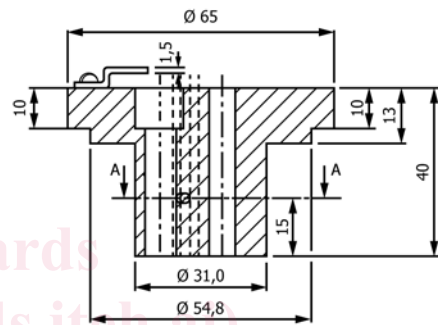

NOTE 1—All dimensions are in millimetres, and the comma (,) is used as the decimal point.

FIG. 5 Stopper with Holes for Thermometer, Pipet, and Vent

part of the stopper shall have an indentation to permit the thermometer (see 6.1.9) to be read down to a temperature of -30°C. A pointer shall be fitted to the upper surface of the stopper to facilitate location of the thermometer in relation to the bottom of the test jar. A spring wire clip shall be used to retain the thermometer in the correct position.

6.1.8 Pipet with Filter Unit:

6.1.8.1 Pipet, of clear glass with a calibration mark corresponding to a contained volume of  $20 \pm 0.2$  mL at a point 149

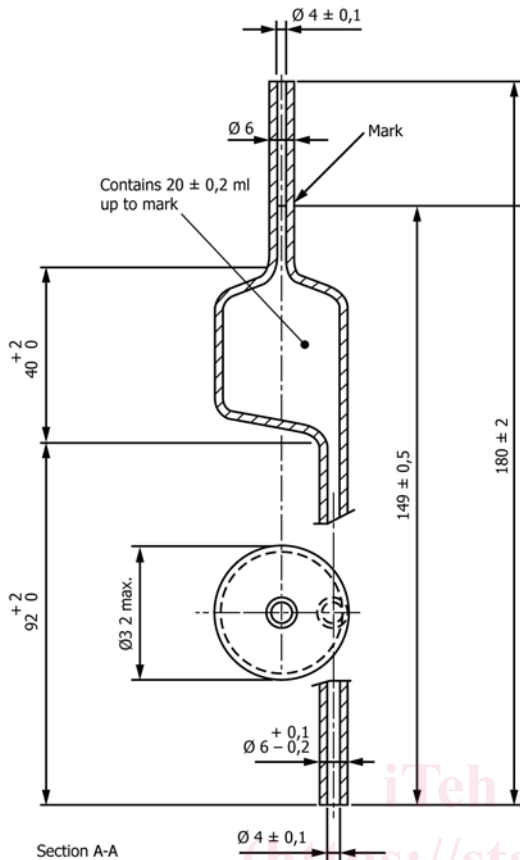

FIG. 6 Pipet

NOTE 1—All dimensions are in millimetres, and the comma (,) is used as the decimal point.

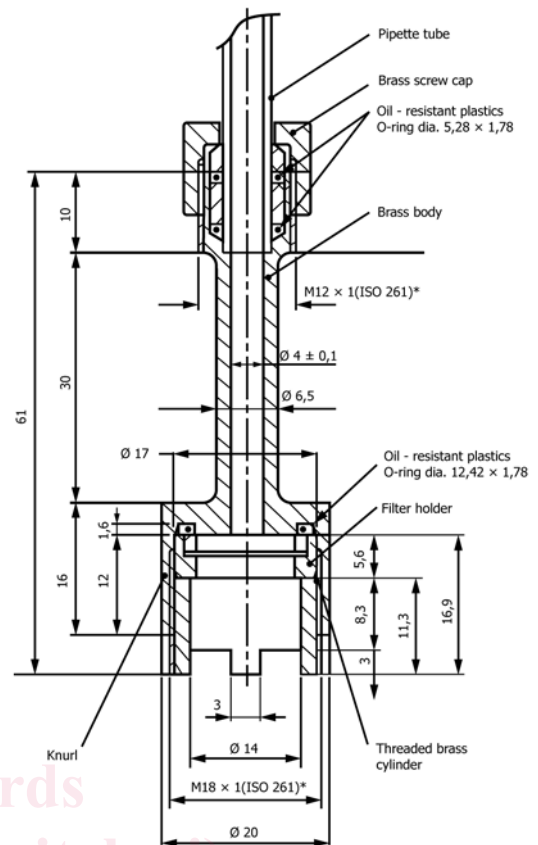

FIG. 7 Filter Unit

NOTE 1—All dimensions are in millimetres, and the comma (,) is used as the decimal point.

± 0.5 mm from the bottom of the pipet (see Fig. 6). It shall be connected to the filter unit (see 6.1.8.2).

6.1.8.2 *Filter Unit* (see Fig. 7), containing the following elements:

(1) *Brass Body*, with a threaded cavity that houses the wire mesh holder. The cavity shall be fitted with an O-ring of oil-resistant plastics. The internal diameter of the central tube shall be  $4 \pm 0.1$  mm.

(2) *Brass Screw Cap*, to connect the upper part of the body of the filter unit (see 6.1.8.2) to the lower part of the pipet (see 6.1.8.1) to ensure a leak-free joint. An example of satisfactory connection is shown in Fig. 7.

(3) *Disc*,  $15 \pm 0.1$ -mm diameter, of plain weave stainless steel wire mesh gauze with a nominal aperture size of  $45 \mu\text{m}$ . The nominal diameter of the wire shall be  $32 \mu\text{m}$ , and the tolerance for the size of an individual aperture shall be as follows:

No aperture size shall exceed the nominal size by more than  $22 \mu\text{m}$ .

The average aperture size shall be within  $\pm 3.1 \mu\text{m}$  of the nominal size.

Not more than 6% of the apertures shall be above the nominal size by more than  $13 \mu\text{m}$ .

(4) *Filter Holder of Brass*, in which the disc of wire mesh gauze (see 6.1.8.2 (3)) is firmly clamped by a retaining ring

pressed into the filter holder. The diameter of the exposed part of the gauze shall be  $12 + 0.1 - 0.0$  mm (see Fig. 8).

(5) *Brass Cylinder*, threaded on the outside, that can be screwed into the cavity of the body (see 6.1.8.2 (1)) to clamp the filter holder (see 6.1.8.2 (4)) against the O-ring (6.1.8.2 (1)). The lower end shall have four slots to allow the specimen to flow into the filter unit.

NOTE 3—The requirements for the wire mesh are taken from IP 3310IP 3310, to which reference may be made for methods for testing the gauze.

6.1.9 *Thermometers*, having ranges shown below and conforming to the requirements prescribed in Specification E1 or Specifications for IP Standard Thermometers.

Thermometer	Temperature Range	Thermometer Number	
		ASTM	IP
High-range for CFPP down to $-30^{\circ}\text{C}$	$-38^{\circ}\text{C}$ to $+50^{\circ}\text{C}$	5C	1C
Low-range from CFPP below $-30^{\circ}\text{C}$	$-80^{\circ}\text{C}$ to $+20^{\circ}\text{C}$	6C	2C
Cooling bath	$-80^{\circ}\text{C}$ to $+20^{\circ}\text{C}$	6C	2C

6.1.10 *Cooling Bath:*

6.1.10.1 The type of cooling bath is optional, but it shall be of a shape and size suitable for containing the jacket (see 6.1.3) in a stable and upright position at the required depth.

6.1.10.2 The bath shall be fitted with a cover with one or more holes in it to accommodate the supporting ring (see 6.1.6). The jacket (see 6.1.3) may be permanently mounted in the cover.