



Designation: ~~C143/C143M-10~~ Designation: C143/C143M – 10a

Standard Test Method for Slump of Hydraulic-Cement Concrete¹

This standard is issued under the fixed designation C143/C143M; the number immediately following the designation indicates the year of original adoption or, in the case of revision, the year of last revision. A number in parentheses indicates the year of last reapproval. A superscript epsilon (ϵ) indicates an editorial change since the last revision or reapproval.

This standard has been approved for use by agencies of the Department of Defense.

1. Scope*

1.1 This test method covers determination of slump of hydraulic-cement concrete, both in the laboratory and in the field.

1.2 The values stated in either SI units or inch-pound units are to be regarded separately as standard. Within the text, the SI units are shown in brackets. The values stated in each system may not be exact equivalents; therefore, each system shall be used independently of the other. Combining values from the two systems may result in non-conformance with the standard.

1.3 The text of this standard references notes and footnotes which provide explanatory material. These notes and footnotes (excluding those in tables and figures) shall not be considered as requirements of the standard.

1.4 *This standard does not purport to address all of the safety concerns, if any, associated with its use. It is the responsibility of the user of this standard to establish appropriate safety and health practices and determine the applicability of regulatory limitations prior to use. (Warning—Fresh hydraulic cementitious mixtures are caustic and may cause chemical burns to skin and tissue upon prolonged exposure.²)*

2. Referenced Documents

2.1 ASTM Standards:³

C31/C31M Practice for Making and Curing Concrete Test Specimens in the Field

C138/C138M Test Method for Density (Unit Weight), Yield, and Air Content (Gravimetric) of Concrete

C172 Practice for Sampling Freshly Mixed Concrete

C173/C173M Test Method for Air Content of Freshly Mixed Concrete by the Volumetric Method

C231 Test Method for Air Content of Freshly Mixed Concrete by the Pressure Method

C670 Practice for Preparing Precision and Bias Statements for Test Methods for Construction Materials

3. Summary of Test Method

3.1 A sample of freshly mixed concrete is placed and compacted by rodding in a mold shaped as the frustum of a cone. The mold is raised, and the concrete allowed to subside. The vertical distance between the original and displaced position of the center of the top surface of the concrete is measured and reported as the slump of the concrete.

4. Significance and Use

4.1 This test method is intended to provide the user with a procedure to determine slump of plastic hydraulic-cement concretes.

NOTE 1—This test method was originally developed to provide a technique to monitor the consistency of unhardened concrete. Under laboratory conditions, with strict control of all concrete materials, the slump is generally found to increase proportionally with the water content of a given concrete mixture, and thus to be inversely related to concrete strength. Under field conditions, however, such a strength relationship is not clearly and consistently shown. Care should therefore be taken in relating slump results obtained under field conditions to strength.

4.2 This test method is considered applicable to plastic concrete having coarse aggregate up to 1½ in. [37.5 mm] in size. If the coarse aggregate is larger than 1½ in. [37.5 mm] in size, the test method is applicable when it is performed on the fraction of concrete passing a 1½-in. [37.5-mm] sieve, with the larger aggregate being removed in accordance with the section titled “Additional Procedure for Large Maximum Size Aggregate Concrete” in Practice C172.

4.3 This test method is not considered applicable to non-plastic and non-cohesive concrete.

¹ This test method is under the jurisdiction of ASTM Committee C09 on Concrete and Concrete Aggregates and is the direct responsibility of Subcommittee C09.60 on Testing Fresh Concrete.

Current edition approved Feb-Oct. 1, 2010. Published March/November 2010. Originally approved in 1922. Last previous edition approved in 2009/2010 as C143/C143M-109. DOI: 10.1520/C0143_C0143M-10a.

² Section on Safety Precautions, Manual of Aggregate and Concrete Testing, *Annual Book of ASTM Standards*, Vol. 04.02.

³ For referenced ASTM standards, visit the ASTM website, www.astm.org, or contact ASTM Customer Service at service@astm.org. For *Annual Book of ASTM Standards* volume information, refer to the standard’s Document Summary page on the ASTM website.

*A Summary of Changes section appears at the end of this standard.

NOTE 2—Concretes having slumps less than 1/2 in. [15 mm] may not be adequately plastic and concretes having slumps greater than about 9 in. [230 mm] may not be adequately cohesive for this test to have significance. Caution should be exercised in interpreting such results.

5. Apparatus

5.1 Mold—The test specimen shall be formed in a mold made of metal not readily attacked by the cement paste. The metal shall not be thinner than 0.060 in. [1.5 mm] and if formed by the spinning process, there shall be no point on the mold at which the thickness is less than 0.045 in. [1.15 mm]. The mold shall be in the form of the lateral surface of the frustum of a cone with the base 8 in. [200 mm] in diameter, the top 4 in. [100 mm] in diameter, and the height 12 in. [300 mm]. Individual diameters and heights shall be within ±1/8 in. [3 mm] of the prescribed dimensions. The base and the top shall be open and parallel to each other and at right angles to the axis of the cone. The mold shall be provided with foot pieces and handles similar to those shown in Fig. 1. The mold shall be constructed without a seam. The interior of the mold shall be relatively smooth and free from projections. The mold shall be free from dents, deformation, or adhered mortar. A mold which clamps to a nonabsorbent base plate is acceptable instead of the one illustrated, provided the clamping arrangement is such that it can be fully released without movement of the mold and the base is large enough to contain all of the slumped concrete in an acceptable test.

5.1.1 Check and record conformance to the mold’s specified dimensions when it is purchased or first placed in service and at least annually thereafter.

5.1.2 Mold with alternative materials.

5.1.2.1 Molds other than metal are allowed if the following requirements are met: The mold shall meet the shape, height, and internal dimensional requirements of 5.1. The mold shall be sufficiently rigid to maintain the specified dimensions and tolerances during use, resistant to impact forces, and shall be nonabsorbent. The mold shall be demonstrated to provide test results comparable to those obtained when using a metal mold meeting the requirements of 5.1. Comparability shall be demonstrated on behalf of the manufacturer by an independent testing laboratory. Test for comparability shall consist of not less than 10 consecutive pairs of comparisons performed at each of 3 different slumps ranging from 2 to 8 in. [50 to 200 mm] (Note 3). No individual test results shall vary by more than 0.50 in. [15 mm] from that obtained using the metal mold. The average test results of each slump range obtained using the mold constructed of alternative material shall not vary by more than 0.25 in. [6 mm] from the average of test results obtained using the metal mold. Manufacturer comparability test data shall be available to users and laboratory inspection authorities (Note 4). If any changes in material or method of manufacture are made, tests for comparability shall be repeated.

NOTE 3—The phrase “consecutive pairs of comparisons” does not mean without interruption or all in one day. At a schedule selected by the testing entity, the pairs of tests leading to 10 consecutive pairs may be accomplished in small groups. The word “consecutive” prevents ignoring pairs of tests which may not meet the criteria.

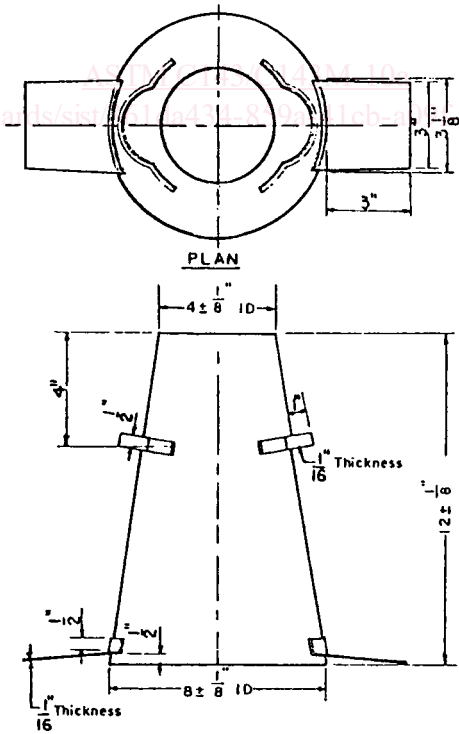

Dimensional Units									
in.	1/16	1/8	1/2	1	3	3 1/8	4	8	12
mm	[2]	[3]	[15]	[25]	[75]	[80]	[100]	[200]	[300]

FIG. 1 Mold for Slump Test