**Physical device control — Interfaces
for automated machine tending —**

**Part 2:
Safety and control interface**

*Ensemble de commande pour les équipements — Interfaces pour le
chargement automatisé des machines —*

Partie 2: Interface de sécurité et de commande

iTeh STANDARD PREVIEW
(standards.iteh.ai)

ISO 21919-2:2021

<https://standards.iteh.ai/catalog/standards/sist/5de76c57-db7f-4a5e-8b95-00fc6b19b0b2/iso-21919-2-2021>



iTeh STANDARD PREVIEW
(standards.iteh.ai)

ISO 21919-2:2021

<https://standards.iteh.ai/catalog/standards/sist/5de76c57-db7f-4a5e-8b95-00fc6b19b0b2/iso-21919-2-2021>



COPYRIGHT PROTECTED DOCUMENT

© ISO 2021

All rights reserved. Unless otherwise specified, or required in the context of its implementation, no part of this publication may be reproduced or utilized otherwise in any form or by any means, electronic or mechanical, including photocopying, or posting on the internet or an intranet, without prior written permission. Permission can be requested from either ISO at the address below or ISO's member body in the country of the requester.

ISO copyright office
CP 401 • Ch. de Blandonnet 8
CH-1214 Vernier, Geneva
Phone: +41 22 749 01 11
Email: copyright@iso.org
Website: www.iso.org

Published in Switzerland

Contents

	Page
Foreword	iv
Introduction	v
1 Scope	1
2 Normative references	1
3 Terms and definitions	1
4 Description of the interfaces	2
4.1 General.....	2
4.2 Characteristics of the interface.....	3
4.2.1 General.....	3
4.2.2 Conformance class.....	3
4.2.3 Conformance options.....	8
4.3 Safety interface.....	13
4.3.1 General.....	13
4.3.2 Principle approach and concept.....	13
4.3.3 Matrix for safety-related functional relationships.....	13
4.3.4 Distribution of performance levels and PFHD value.....	15
4.4 Control interface.....	16
5 Extension of the interfaces	16
5.1 General.....	16
5.2 Examples of project-specific extensions.....	16
5.2.1 General.....	16
5.2.2 Additional signals.....	16
5.2.3 More than one interference area.....	16
Annex A (normative) List of signals	17
Annex B (informative) Examples for safety matrices	18
Annex C (normative) Flow charts	31
Bibliography	44

Foreword

ISO (the International Organization for Standardization) is a worldwide federation of national standards bodies (ISO member bodies). The work of preparing International Standards is normally carried out through ISO technical committees. Each member body interested in a subject for which a technical committee has been established has the right to be represented on that committee. International organizations, governmental and non-governmental, in liaison with ISO, also take part in the work. ISO collaborates closely with the International Electrotechnical Commission (IEC) on all matters of electrotechnical standardization.

The procedures used to develop this document and those intended for its further maintenance are described in the ISO/IEC Directives, Part 1. In particular, the different approval criteria needed for the different types of ISO documents should be noted. This document was drafted in accordance with the editorial rules of the ISO/IEC Directives, Part 2 (see www.iso.org/directives).

Attention is drawn to the possibility that some of the elements of this document may be the subject of patent rights. ISO shall not be held responsible for identifying any or all such patent rights. Details of any patent rights identified during the development of the document will be in the Introduction and/or on the ISO list of patent declarations received (see www.iso.org/patents).

Any trade name used in this document is information given for the convenience of users and does not constitute an endorsement.

For an explanation of the voluntary nature of standards, the meaning of ISO specific terms and expressions related to conformity assessment, as well as information about ISO's adherence to the World Trade Organization (WTO) principles in the Technical Barriers to Trade (TBT), see www.iso.org/iso/foreword.html.

This document was prepared by Technical Committee ISO/TC 184, *Automation systems and integration*, Subcommittee SC 1, *Physical device control*.

A list of all parts in the ISO 21919 series can be found on the ISO website.

Any feedback or questions on this document should be directed to the user's national standards body. A complete listing of these bodies can be found at www.iso.org/members.html.

Introduction

The ISO 21919 series describes interfaces for automated machine tending of at least one computer numerically controlled (CNC) machine by using a machine tending system. These interfaces are the link between automated machine tending systems and machines used for production. The automated machine tending is initiated by either the machine tending system or by the machine.

ISO 21919-1 gives an overview and defines the fundamental principles on how the interfaces are set up. It defines the necessary vocabulary and sets the syntax for the structure of signals. It distinguishes between the safety interface, the control interface and project specific extensions.

Automated machine tending refers to the automatic loading or unloading of one or more machines by using a machine tending system.

EXAMPLE Examples for machines are machine tools, typically computer numerically controlled (CNC), metrology co-ordinate measuring machines (CMM), 3D structured light scanner (3DSL), and X-ray machines. Examples for machine tending systems are robots, handling systems, gantrys, autonomous intelligent vehicles (AIV), and automated guided vehicles (AGV).

Automated machine tending is a substantial element in highly productive industrial environments. It is a complex endeavour. Necessary devices are complex systems by itself, are oftentimes provided by different suppliers and encounter each other at the production site first time. For a trouble-free collaboration of all units a clear definition of the interfaces is indispensable. For manufacturing systems such standardized interfaces at an international level haven't been defined yet.

Therefore, the definition of the interfaces often is project-specific from the scratch or each supplier tries to establish its in-house standards. These procedures cause great efforts, are prone to failure and hence take a lot of time and manpower. As each interface is built individually and testing beforehand is often not possible, commissioning times exceed the planned ones. Machine builders, system integrators and production plant operators report these issues being substantial obstacles for such automation projects.

<https://standards.iteh.ai/catalog/standards/sist/5de76c57-db7f-4a5e-8b95-00fc6b19b0b2/iso-21919-2-2021>

Standardized interfaces lead to lean coordination processes, give higher planning reliability, shorten times for commissioning and are less error-prone.

On the other hand, automated machine tending systems can be very complex systems and standards need to be flexible enough to allow an adaption to the requirements of individual projects.

Applications are ranging from simple parts removal to material flow dedicated complex production lines. It is noteworthy that the processing technologies of the machines are independent to the interface and a majority of machine technologies can be integrated with the same standard.

[Figure 1](#) and [Figure 2](#) display the range of complexity of machine tending systems covered by the ISO 21919 series. [Figure 1](#) shows an example of a simple automated machine tending system, consisting of a machine tool loaded by a conveyor.

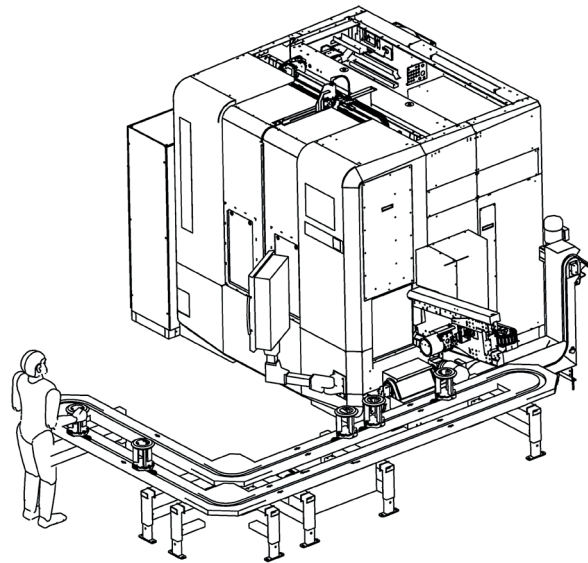

Figure 1 — Example of a simple automated machine tending system

Figure 2 shows an example of a complex production line with five computer numerically controlled machine tools tended by a loading gantry.

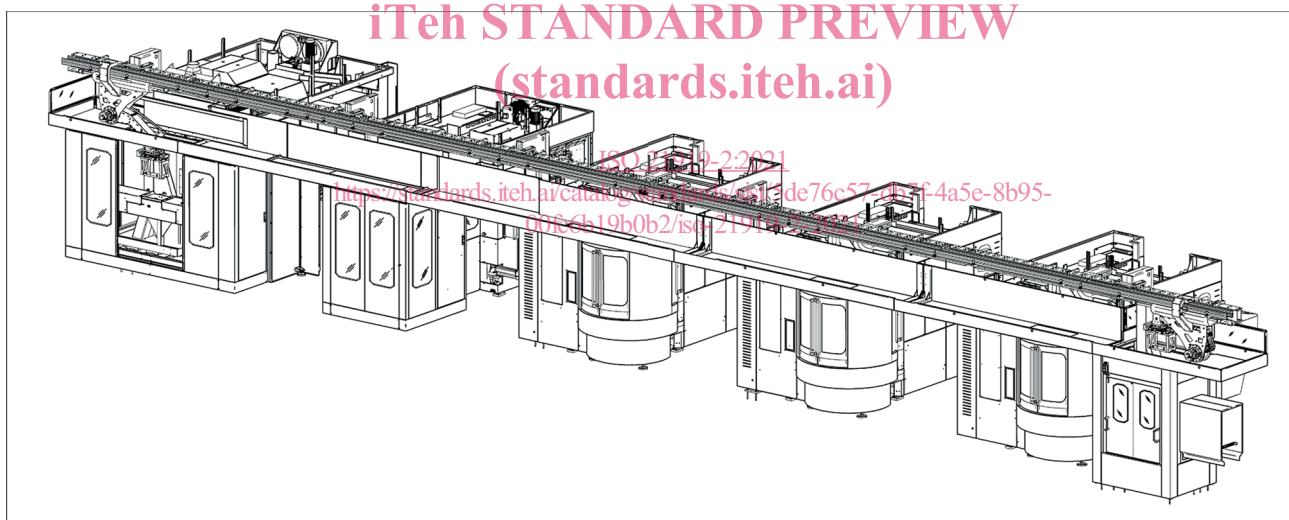

Figure 2 — Example of a complex production line loaded by a gantry

In general, the interfaces for automated machine tending are composed of:

- mechanical;
- control-related; and
- safety-related connections.

Physical device control — Interfaces for automated machine tending —

Part 2: Safety and control interface

1 Scope

This document deals with the safety interface and control interface. It allocates signals to a conformance class and/or conformance option. It describes the detailed functions of each signal, describes and displays the timing interactions between signals in flow charts and shows examples for safety matrices and safety-related functional relationships.

This document defines three conformance classes and dedicated conformance options. Classes and options consist of a number of signals to:

- allow a flexible adaptation of the interface(s) to a project-specific scope of functions and simultaneously;
- tie sets of signals tight enough to avoid unnecessary coordination efforts between suppliers of the machine tending systems and machines.

2 Normative references

[ISO 21919-2:2021](https://standards.iteh.ai/catalog/standards/sist/5de76c57-db7f-4a5e-8b95-701c0b19b002/iso-21919-2-2021)

The following documents are referred to in the text in such a way that some or all of their content constitutes requirements of this document. For dated references, only the edition cited applies. For undated references, the latest edition of the referenced document (including any amendments) applies.

ISO 13849-1, *Safety of machinery — Safety-related parts of control systems — Part 1: General principles for design*

ISO 21919-1, *Automation systems and integration — Interfaces for automated machine tending — Part 1: Overview and fundamental principles*

IEC 62061, *Safety of machinery – Functional safety of safety-related electrical, electronic and programmable electronic control systems*

3 Terms and definitions

For the purposes of this document, the terms and definitions given in ISO 21919-1 and the following apply.

ISO and IEC maintain terminological databases for use in standardization at the following addresses:

- ISO Online browsing platform: available at <https://www.iso.org/obp>
- IEC Electropedia: available at <http://www.electropedia.org/>

3.1

emergency stop

function which is intended to

- avert arising or reduce existing hazards to persons, damage to machinery or to work in progress, and

- be initiated by a single human action

Note 1 to entry: ISO 13850 gives detailed provisions.

[SOURCE: ISO 12100:2010, 3.40]

3.2

guard

physical barrier, designed as part of a functional unit to provide protection

[SOURCE: ISO 12100:2010, 3.27, modified — In the definition, "the machine" has been changed to "a functional unit". Notes 1 to 3 to entry have been removed.]

3.3

part family

all parts that a machine accepts for processing without a new set up

Note 1 to entry: A part family consists at least of one part.

4 Description of the interfaces

4.1 General

For an extensive description of the interfaces for automated machine tending, the following interfaces shall be defined:

- safety interface;
- control interface.

iTeh STANDARD PREVIEW
(standards.iteh.ai)

[Figure 3](#) shows the principle setup of the interfaces for automated machine tending.

ISO 21919-2:2021
<https://standards.iteh.ai/catalog/standards/sist/5de76c57-d071-4a5c-8b95-00fc6b19b0b2/iso-21919-2-2021>

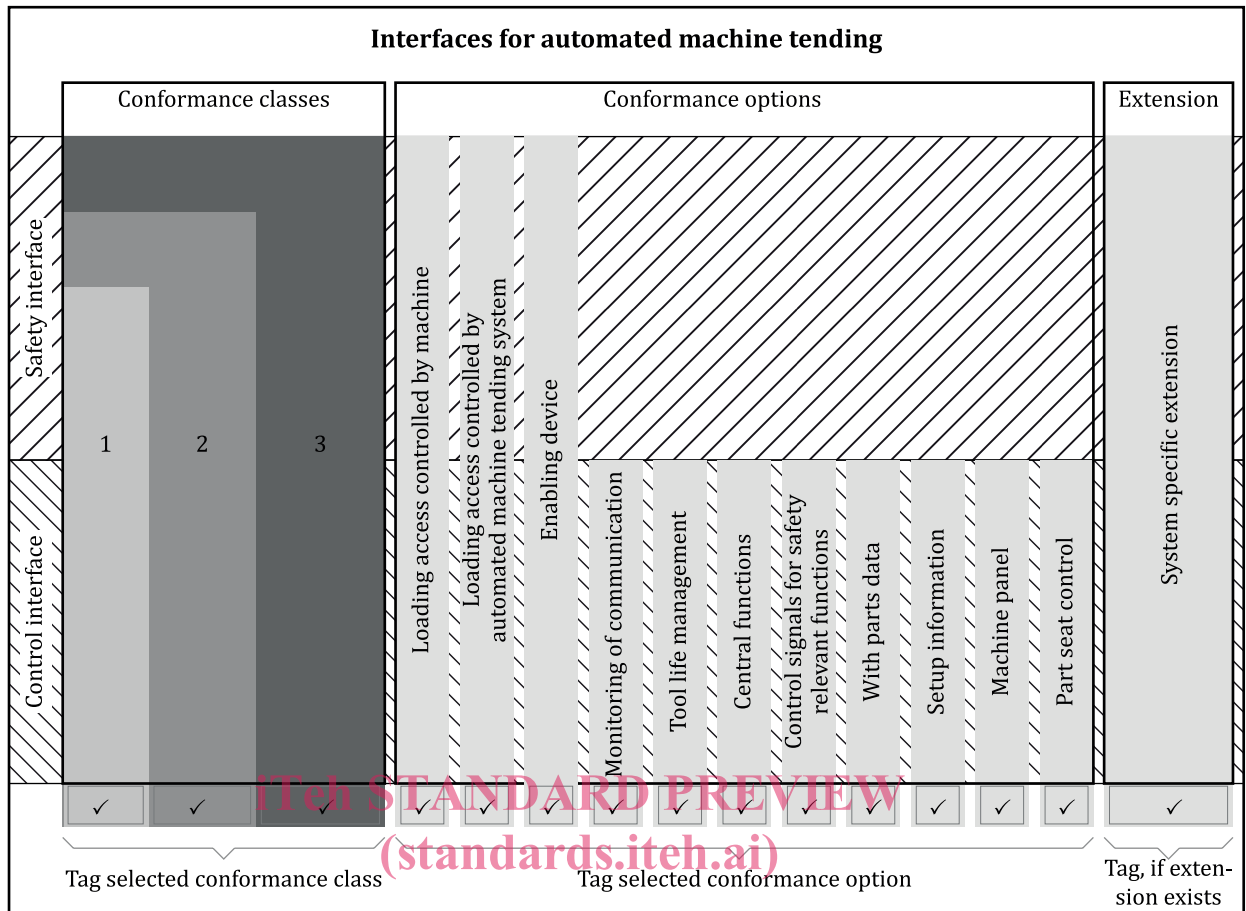

ISO 21919-2:2021
<https://standards.iteh.ai/catalog/standards/sist/5de76e57-d87f-4a5e-8b95-00fc6b19b0b2/iso-21919-2-2021>
Figure 3 – Principle setup of the interface

4.2 Characteristics of the interface

4.2.1 General

The signals are grouped in conformance classes and conformance options for a flexible adaptation of the interface to the project-specific sets of functions. Grouping allows individual characterization of the interface while simultaneously meeting the requirements of this document.

For the application of this document, one conformance class shall be selected, all desired conformance options can be selected, and a project specific extension can be defined.

The signals assigned to the relevant conformance class or the relevant conformance option shall be made available at the interface if the characteristics on this conformance class/conformance option are selected.

When realizing the interface, the signals shall correlate in the way shown in the relevant flow charts in [Annex C](#).

4.2.2 Conformance class

4.2.2.1 General

With the selection of a conformance class a basic set of signals is selected in order to fulfil the task of automated machine tending.

The following conformance classes are available. Only one conformance class shall be selected.

- Conformance class 1: Minimum set of signals.
- Conformance class 2: Extended set of signals.
- Conformance class 3: Extended set of signals with process optimization.

4.2.2.2 Conformance class 1: Minimum set of signals

4.2.2.2.1 General

At conformance class 1, the following functions can be realized:

- safety of people;
- simple unloading;
- simple loading;
- simple combined unloading and loading.

The word "simple" indicates that there is no distinction between coherent and non-coherent transfer and that clamping functions are not handled via the interface.

Conformance class 1 is not applicable for machines that need coherent transfer.

4.2.2.2.2 Simple unloading

The function "simple unloading" serves the requirement to unload one part from the machine.

See the corresponding flow chart in [Figure C.1](#).

[ISO 21919-2:2021](https://standards.iteh.ai/catalog/standards/sist/5de76c57-db7f-4a5e-8b95-00fc6b19b0b2/iso-21919-2-2021)

<https://standards.iteh.ai/catalog/standards/sist/5de76c57-db7f-4a5e-8b95-00fc6b19b0b2/iso-21919-2-2021>

4.2.2.2.3 Simple loading

The function "simple loading" serves the requirement to load one part to the machine.

See the corresponding flow chart in [Figure C.2](#).

4.2.2.2.4 Simple combined unloading and loading

The function "simple combined unloading and loading" serves the requirement to unload one part from the machine and then load another part after that. The time period between unloading and subsequent loading is not defined.

However, the restriction applies that there shall be no machine movements required in the interference area during the loading and unloading process. In this case, the automated machine tending system can remain within the interference area.

See the corresponding flow chart in [Figure C.3](#).

4.2.2.3 Conformance class 2: Extended set of signals

4.2.2.3.1 General

At conformance class 2, all functions of conformance class 1 and the following can be realized:

- unloading with non-coherent transfer, with/without clamping function;
- unloading with coherent transfer;

- loading with non-coherent transfer, with/without clamping function;
- loading with coherent transfer;
- combined unloading and loading with non-coherent transfer, with/without clamping function;
- combined unloading and loading with coherent transfer;
- preparation of a part;
- emptying;
- functions of guard doors;
- further status information.

NOTE Conformance class 2 and conformance class 3 are typically implemented as bus interface as many signals are handled.

4.2.2.3.2 Unloading with non-coherent transfer, with/without clamping function

Function "Unloading with non-coherent transfer, with/without clamping function" serves the requirement to unload a part from the machine at non-coherent transfer.

See the corresponding flow chart in [Figure C.4](#).

4.2.2.3.3 Unloading with coherent transfer

Function "Unloading with non-coherent transfer, with clamping function" serves the requirement to unload a part from the machine at coherent transfer.

See the corresponding flow chart in [Figure C.5](#).
ISO 21919-2:2021
<https://standards.iteh.ai/catalog/standards/sist/5de76c57-db7f-4a5e-8b95-00fc6b19b0b2/iso-21919-2-2021>

4.2.2.3.4 Loading with non-coherent transfer, with/without clamping function

Function "Loading with non-coherent transfer, with/without clamping function" serves the requirement to load a part from the machine at non-coherent transfer.

See the corresponding flow chart in [Figure C.6](#).

4.2.2.3.5 Loading with coherent transfer

Function "Loading with coherent transfer" serves the requirement to load a part from the machine at fixed transfer.

See the corresponding flow chart in [Figure C.7](#).

4.2.2.3.6 Combined unloading and loading with non-coherent transfer, with/without clamping function

Function "Combined unloading and loading with non-coherent transfer, with/without clamping function" serves the requirement to unload a part from the machine at not fixed transfer and then load another part to the machine. The time period between unloading and subsequent loading is not defined.

See the corresponding flow chart in [Figure C.8](#).

4.2.2.3.7 Combined unloading and loading with coherent transfer

Function "Combined unloading and loading with coherent transfer, with/without clamping function" serves the requirement to unload a part from the machine at coherent transfer and then load another part to the machine. The time period between unloading and subsequent loading is not defined.

See the corresponding flow chart in [Figure C.9](#).

4.2.2.3.8 Preparation of a part

Function "Preparation of a part" is used to inform the automated machine tending system at an early stage that there is no part at the loading space of the machine or that the machine will complete processing shortly.

4.2.2.3.9 Emptying

Function "Emptying" serves the requirement to unload all parts from the machine.

Emptying can be requested from the automated machine tending system to the machine, e.g. if there are no new raw parts.

If the machine needs to have all parts unloaded, it shall send a request to the automated machine tending system. Automated machine tending system decides when the machine can be unloaded and acknowledges the request by setting its request for emptying. Up to this point, the machine shall request loading cycles.

See the corresponding flow chart in [Figure C.10](#).

4.2.2.3.10 Function of guard doors

The functions of the guard doors serve the requirement to unlock the guard door(s), if necessary. Here, distinction shall be made whether the guard door is assigned to the automated machine tending system or to the machine. It can also be differentiated if a request for unlocking the guard door remains until the guard door has actually been unlocked or if the request has prematurely been withdrawn.

[Figure C.11](#) differentiates between the two cases and shows the corresponding flow charts.

<https://standards.iteh.ai/catalog/standards/sist/5de76c57-db7f-4a5e-8b95-00fc6b19b0b2/iso-21919-2-2021>

4.2.2.3.11 Further status functions

Conformance class 2 contains further signals which provide information at the interface.

4.2.2.4 Conformance class 3: Extended set of signals with process optimization

4.2.2.4.1 General

At conformance class 3, all functions of conformance class 2 and the following can be realized:

- process optimizations at the combined unloading and loading with coherent transfer;
- process optimizations at the combined unloading and loading with non-coherent transfer, with/without clamping function;
- process optimizations, if pre-positioning by the machine;
- process optimizations, if clamping and releasing is executed in more than one step.

4.2.2.4.2 Process optimizations at combined unloading and loading

4.2.2.4.2.1 General

Description of pre-positioning by the automated machine tending system.

[Figure 4](#) displays the principle coherence of different typical areas of machine and automated machine tending system and its interactions.

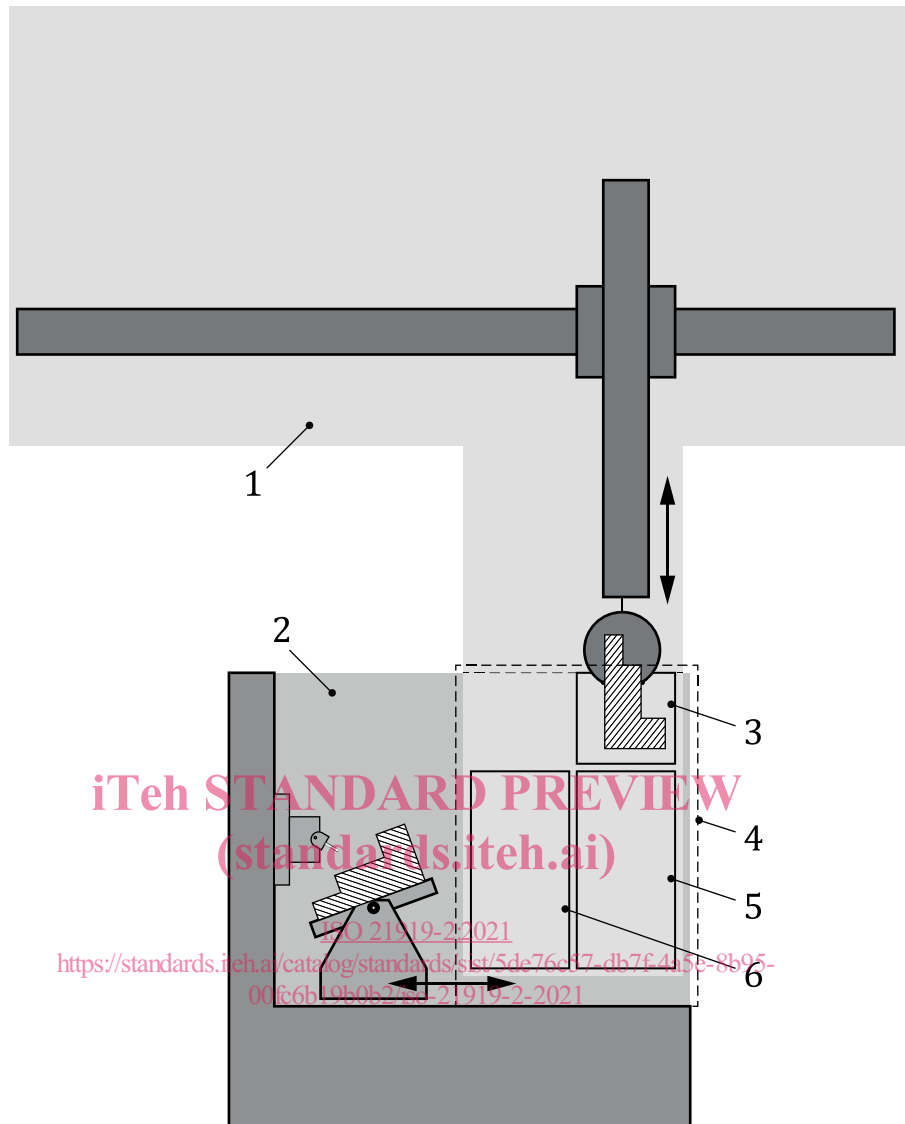

Key

- 1 range of automated machine tending system
- 2 range of machine
- 3 interference area preposition automated machine tending system
- 4 interference area
- 5 location of transfer station
- 6 interference area preposition machine

Figure 4 — Interference area at pre-positioning by automated machine tending system

Involved signals are AM_ENA_InIntfrArea, AM_STA_OutIntfrArea, AM_STA_OutIntfrAreaFixt, MA_ENA_InIntfrArea, MA_ENA_InIntfrAreaPrePos, and MA_STA_OutIntfrArea. For definition of these signals, see [Annex A](#).

4.2.2.4.2.2 With coherent transfer

The process optimizations at the combined unloading and loading with coherent transfer function unloads a part from the machine at coherent transfer and then load another part to the machine. The time period between unloading and subsequent loading is not defined.

In addition to conformance class 2, process optimizations (optimization of cycle time) are carried out concerning:

- pre-positionings;
- preparation of unloading part(s).

See the corresponding flow chart in [Figure C.13](#).

4.2.2.4.2.3 With non-coherent transfer, with/without clamping function

Function "Combined unloading and loading with non-coherent transfer, with/without clamping function" serves the requirement to unload apart from the machine at non-coherent transfer and then load another part to the machine. The time period between unloading and subsequent loading is not defined.

In addition to conformance class 2, process optimizations (optimization of cycle time) are carried out concerning:

- pre-positionings;
- preparation of unloading part(s).

See the corresponding flow chart in [Figure C.12](#).

4.2.2.4.3 Process optimizations, if pre-positioning by machine

In conformance class 3, signals are provided for process optimizations which require a pre-positioning of the machine. A process description shall be coordinated specifically to the project and depending on the mechanical design.

4.2.2.4.4 Process optimizations, if clamping and releasing is executed in more than one step

In conformance class 3, signals are provided for process optimizations which require clamping and releasing in more than one step. A process description shall be coordinated specifically to the project and depending on the mechanical design.

4.2.3 Conformance options

4.2.3.1 General

The selection of a conformance option allows adding an additional scope of functions to the selected conformance class. The set of signals allocated to a conformance option is intended to fulfil a specific task.

The following conformance options are available. Any desired conformance option can be selected.

- loading access controlled by machine;
- loading access controlled by automated machine tending system;
- enabling device;
- monitoring of communication;
- tool life management;
- central functions;
- control signals for safety-relevant functions;

- with parts data;
- setup information;
- machine panel;
- part seat control.

[Table 1](#) shows if a conformance option contains safety-relevant and/or control-relevant signals.

Table 1 — Allocation of safety-relevant and control-relevant signals to conformance options

Conformance option	Safety-relevant signals	Control-relevant signals
Loading access controlled by machine	✓	✓
Loading access controlled by automated machine tending system	✓	✓
Enabling device	✓	✓
Monitoring of communication		✓
Tool life management		✓
Central functions		✓
Control signals for safety-relevant functions		✓
With parts data		✓
Setup information		✓
Machine panel		✓
Part seat control		✓

4.2.3.2 Conformance option: Loading access controlled by machine

The signals assigned to the conformance option "Loading access controlled by machine" in [Annex A](#) shall be provided at the interface.

The conformance option "Loading access controlled by machine" includes signals with the belonging functions required if a loading access is controlled by the machine.

Handling the signals is analogous to the description and diagrams of the guard doors.

4.2.3.3 Conformance option: Loading access controlled by automated machine tending system

The signals assigned to the conformance option "Loading access controlled by automated machine tending system" in [Annex A](#) shall be provided at the interface.

The conformance option "Loading access controlled by automated machine tending system" includes signals with the belonging functions which are required if a loading access is controlled by the automated machine tending system.

Handling the signals is analogous to the description and diagrams of the guard doors.

4.2.3.4 Conformance option: Enabling device

The signals assigned to the conformance option "Enabling device" in [Annex A](#) shall be provided at the interface.

The conformance option "Enabling device" includes signals with the belonging functions which are necessary for operating the system in enabling mode.