

ISO/TC 48

Secretariat: DIN

Voting begins on:
2021-11-17

Voting terminates on:
2022-01-12

Piston-operated volumetric apparatus —

Part 9: Manually operated precision laboratory syringes

iTeh STANDARD PREVIEW
Appareils volumétriques à piston —
(standards.iteh.ai)
Partie 9: Seringues de laboratoire haute précision pour utilisation
manuelle

[ISO/FDIS 8655-9](#)

<https://standards.iteh.ai/catalog/standards/sist/f260a8bd-1676-45c4-bfba-b8ab3ef326ac/iso-fdis-8655-9>

ISO/CEN PARALLEL PROCESSING

RECIPIENTS OF THIS DRAFT ARE INVITED TO SUBMIT, WITH THEIR COMMENTS, NOTIFICATION OF ANY RELEVANT PATENT RIGHTS OF WHICH THEY ARE AWARE AND TO PROVIDE SUPPORTING DOCUMENTATION.

IN ADDITION TO THEIR EVALUATION AS BEING ACCEPTABLE FOR INDUSTRIAL, TECHNOLOGICAL, COMMERCIAL AND USER PURPOSES, DRAFT INTERNATIONAL STANDARDS MAY ON OCCASION HAVE TO BE CONSIDERED IN THE LIGHT OF THEIR POTENTIAL TO BECOME STANDARDS TO WHICH REFERENCE MAY BE MADE IN NATIONAL REGULATIONS.



Reference number
ISO/FDIS 8655-9:2021(E)

iTeh STANDARD PREVIEW
(standards.iteh.ai)

[ISO/FDIS 8655-9](https://standards.iteh.ai/catalog/standards/sist/f260a8bd-1676-45c4-bfba-b8ab3ef326ac/iso-fdis-8655-9)

<https://standards.iteh.ai/catalog/standards/sist/f260a8bd-1676-45c4-bfba-b8ab3ef326ac/iso-fdis-8655-9>



COPYRIGHT PROTECTED DOCUMENT

© ISO 2021

All rights reserved. Unless otherwise specified, or required in the context of its implementation, no part of this publication may be reproduced or utilized otherwise in any form or by any means, electronic or mechanical, including photocopying, or posting on the internet or an intranet, without prior written permission. Permission can be requested from either ISO at the address below or ISO's member body in the country of the requester.

ISO copyright office
CP 401 • Ch. de Blandonnet 8
CH-1214 Vernier, Geneva
Phone: +41 22 749 01 11
Email: copyright@iso.org
Website: www.iso.org

Published in Switzerland

Contents

	Page
Foreword.....	iv
Introduction.....	v
1 Scope.....	1
2 Normative references.....	1
3 Terms and definitions.....	1
4 Principle of operation.....	2
5 Design and adjustment.....	3
5.1 Materials.....	3
5.2 Construction requirements.....	3
5.3 Reading of the scale.....	4
5.4 Basis of adjustment.....	4
5.5 Initial adjustment.....	4
6 Metrological performance requirements.....	4
6.1 General.....	4
6.2 Calculation of maximum permissible errors not given in Table 2	5
7 User information.....	5
8 Marking.....	6
Bibliography.....	7

iTeh STANDARD PREVIEW
(standards.iteh.ai)

[ISO/FDIS 8655-9](#)

<https://standards.iteh.ai/catalog/standards/sist/f260a8bd-1676-45c4-bfba-b8ab3ef326ac/iso-fdis-8655-9>

Foreword

ISO (the International Organization for Standardization) is a worldwide federation of national standards bodies (ISO member bodies). The work of preparing International Standards is normally carried out through ISO technical committees. Each member body interested in a subject for which a technical committee has been established has the right to be represented on that committee. International organizations, governmental and non-governmental, in liaison with ISO, also take part in the work. ISO collaborates closely with the International Electrotechnical Commission (IEC) on all matters of electrotechnical standardization.

The procedures used to develop this document and those intended for its further maintenance are described in the ISO/IEC Directives, Part 1. In particular, the different approval criteria needed for the different types of ISO documents should be noted. This document was drafted in accordance with the editorial rules of the ISO/IEC Directives, Part 2 (see www.iso.org/directives).

Attention is drawn to the possibility that some of the elements of this document may be the subject of patent rights. ISO shall not be held responsible for identifying any or all such patent rights. Details of any patent rights identified during the development of the document will be in the Introduction and/or on the ISO list of patent declarations received (see www.iso.org/patents).

Any trade name used in this document is information given for the convenience of users and does not constitute an endorsement.

For an explanation of the voluntary nature of standards, the meaning of ISO specific terms and expressions related to conformity assessment, as well as information about ISO's adherence to the World Trade Organization (WTO) principles in the Technical Barriers to Trade (TBT), see www.iso.org/iso/foreword.html.

This document was prepared by Technical Committee ISO/TC 48, *Laboratory equipment*, in collaboration with the European Committee for Standardization (CEN) Technical Committee CEN/TC 332, *Laboratory equipment*, in accordance with the Agreement on technical cooperation between ISO and CEN (Vienna Agreement).

A list of all parts in the ISO 8655 series can be found on the ISO website.

Any feedback or questions on this document should be directed to the user's national standards body. A complete listing of these bodies can be found at www.iso.org/members.html.

Introduction

The ISO 8655 series addresses the needs of:

- manufacturers, as a basis for quality control including, where appropriate, the issuance of manufacturer's declarations;
- calibration laboratories, test houses, users of the equipment and other bodies as a basis for independent calibration, testing, verification, and routine tests.

The tests specified in the ISO 8655 series are intended to be carried out by trained personnel.

iTeh STANDARD PREVIEW (standards.iteh.ai)

[ISO/FDIS 8655-9](https://standards.iteh.ai/catalog/standards/sist/f260a8bd-1676-45c4-bfba-b8ab3ef326ac/iso-fdis-8655-9)

<https://standards.iteh.ai/catalog/standards/sist/f260a8bd-1676-45c4-bfba-b8ab3ef326ac/iso-fdis-8655-9>

iTeh STANDARD PREVIEW
(standards.iteh.ai)

ISO/FDIS 8655-9

<https://standards.iteh.ai/catalog/standards/sist/f260a8bd-1676-45c4-bfba-b8ab3ef326ac/iso-fdis-8655-9>

Piston-operated volumetric apparatus —

Part 9: Manually operated precision laboratory syringes

1 Scope

This document specifies

- metrological requirements,
- maximum permissible errors,
- requirements for marking and
- information to be provided for users,

for manually operated precision laboratory syringes made of glass or glass and metal designed to deliver their selected volume (Ex).

Manually operated precision laboratory syringes are instruments used for delivering liquids and gases. The barrel is typically made of glass and the plunger and the needle are typically made of metal.

2 Normative references

The following documents are referred to in the text in such a way that some or all of their content constitutes requirements of this document. For dated references, only the edition cited applies. For undated references, the latest edition of the referenced document (including any amendments) applies.

ISO 719, *Glass — Hydrolytic resistance of glass grains at 98 °C — Method of test and classification*

ISO 3696:1987, *Water for analytical laboratory use — Specification and test methods*

ISO 8655-1:—¹⁾, *Piston-operated volumetric apparatus — Part 1: Terminology, general requirements and user recommendations*

ISO 8655-6, *Piston-operated volumetric apparatus — Part 6: Gravimetric reference measurement procedure for the determination of volume*

ISO 8655-7, *Piston-operated volumetric apparatus — Part 7: Alternative measurement procedures for the determination of volume*

ISO 8655-8, *Piston-operated volumetric apparatus — Part 8: Photometric reference measurement procedure for the determination of volume*

3 Terms and definitions

For the purposes of this document, the terms and definitions given in ISO 8655-1:— and the following apply.

ISO and IEC maintain terminological databases for use in standardization at the following addresses:

- ISO Online browsing platform: available at <https://www.iso.org/obp>

1) Under preparation. Stage at the time of publication: ISO/FDIS 8655-1:2021.

— IEC Electropedia: available at <https://www.electropedia.org/>.

3.1 barrel flange

finger grips

flanges that protrude from the barrel (also referred to as finger grips) to provide the user an ergonomic means of gripping the syringe during injection

[SOURCE: ISO 7886-1:2017, 3.16 — modified, alternative term introduced.]

3.2 fiducial line

leading edge on the plunger stopper that is in contact with and perpendicular to the syringe barrel and aligns with the zero when the plunger is fully inserted

[SOURCE: ISO 7886-1:2017, 3.5, modified — "zero marking on the syringe barrel" replaced by "zero" (see 3.7) and used "plunger" instead of "piston".]

3.3 graduation line

line defining the position on the scale

Note 1 to entry: Requirements for graduation lines are given in ISO 7886-1:2017.

3.4 nominal volume

(syringes) maximum useable volume specified by the manufacturer

3.5 plunger stopper

component connected to the leading end of the plunger and seals the open end of the syringe barrel

[SOURCE: ISO 7886-1:2017, 3.11] <https://standards.iteh.ai/catalog/standards/sist/f260a8bd-1676-45c4-bfba-b8ab3ef326ac/iso-fdis-8655-9>

3.6 plunger

device component which advances the *plunger stopper* (3.5) to deliver the content of the syringe barrel

[SOURCE: ISO 7886-1:2017, 3.18, modified — "deliver the medicinal product" replaced with "deliver the content of the syringe barrel".]

3.7 zero

beginning of the measuring scale

Note 1 to entry: It may be marked with a scale line or be the end of the plunger course corresponding to plunger fully inserted.

4 Principle of operation

Precision laboratory syringes are instruments used for delivering liquids or gases and can be used for total or partial delivery. Syringes graduated in microlitres are called micro syringes.

With the piston positioned at the lower aspiration limit, the needle is immersed in the liquid to be dispensed. By pulling the piston above the volume to be dispensed the liquid is aspirated. The piston is then positioned on the volume to be dispensed. The liquid to be dispensed is then expelled by pushing the plunger down to the lower aspiration limit.

The piston should not be touched in order to prevent contamination and should only be operated by the push button. The barrel should only be held at the barrel flange (finger grips) to prevent heat exchange.

Syringes can be used with fixed or removable needles of several fitting types. In special cases, needles may not be required at all.

Figure 1 shows a manually operated precision laboratory syringe.

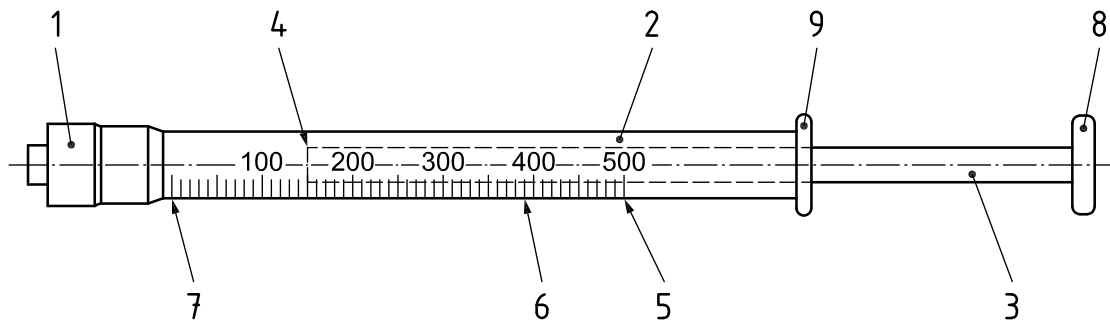

Key

1	nozzle/needle holder	6	graduation lines
2	barrel	7	zero
3	piston	8	push button
4	fiducial line	9	barrel flanges/finger grips
5	nominal capacity		

Figure 1 — Manually operated precision laboratory syringe

5 Design and adjustment

5.1 Materials

<https://standards.iteh.ai/catalog/standards/sist/f260a8bd-1676-45c4-bfba-b8ab3ef326ac/iso-fdis-8655-9>

Manually operated precision laboratory syringes are primarily made of glass or glass and metal.

The design and materials of the syringes shall allow cleaning.

The glass shall be free of internal stresses. When tested according to ISO 719 the glass shall have a resistance to water not lower than HGB3.

The coefficient of cubic thermal expansion for the materials most commonly used in the manufacture of syringes is described in [Table 1](#).

Table 1 — Coefficient of cubic thermal expansion for the materials most commonly used in the manufacture of syringes

Material	Coefficient of cubic thermal expansion ^a γ (°C ⁻¹)
Borosilicate glass 3.3	0,000 010
Borosilicate glass 5.0 (neutral glass)	0,000 015

^a Values described in ISO 4787:2021, Annex D

5.2 Construction requirements

Syringes shall have three main components: the barrel, the piston and the nozzle or needle holder. Other fittings may also be used.

The following requirements shall be fulfilled:

- the total system shall not leak;

- the scale shall be permanently marked on the barrel, uniform and regular;
- the zero, if marked, shall not be covered in a way that makes it invisible;
- all the marks shall have the same thickness; it is not allowed that any mark is thicker than other in order to make it more prominent;
- the thickness of each mark shall be the same throughout the length;
- the quality of the marks shall be such as to minimize reading errors.

5.3 Reading of the scale

The end of the piston which enters the barrel of the syringe shall have a clear fiducial line for setting the piston on any graduation line.

The reading of the piston position, relating to the scale, shall be taken by one of the following options:

- coloured marker at the head of the piston;
- edge of the flat surface at the head of piston;
- circular edge of the piston with a bevelled end, in contact with the barrel;
- edge between head of the piston and body of the piston.

Any index used for the reading of the scale, being the edge of the piston, the piston head, the edge of the bevel or other, shall be coincident with the zero when the piston is fully inserted. Any variation shall not exceed the value of 0,5 mm or one quarter of the scale spacing (smallest division).

All graduation lines shall lie in planes at right angles to the longitudinal axis of the graduated part of the syringe.

<https://standards.iteh.ai/catalog/standards/sist/f260a8bd-1676-45c4-bfba-194de1e41865/iso-8655-9>

The inscriptions and numbers shall be easily legible. The scale marks, inscriptions, numbers and other signs shall be permanently marked. See [Figure 1](#) for details.

5.4 Basis of adjustment

A syringe shall be adjusted for the delivery (Ex) of its nominal volume.

For countries that have adopted the standard reference temperature of 20 °C, the adjustment shall be for the temperature 20 °C, a relative air humidity of 50 % and a barometric pressure of 101,3 kPa, when handling grade 3 water as specified in ISO 3696:1987.

For those countries that have adopted a standard reference temperature of 27 °C, the adjustment shall be for the temperature 27 °C, a relative air humidity of 50 % and a barometric pressure of 101,3 kPa, when handling grade 3 water as specified in ISO 3696:1987.

5.5 Initial adjustment

A syringe shall be provided with an initial adjustment.

6 Metrological performance requirements

6.1 General

In order to state the metrological trueness and precision of the total system of the syringe, and thus determine its systematic and random errors, a reference measurement procedure as specified in ISO 8655-6 and ISO 8655-8 or a measurement procedure according ISO 8655-7 shall be used. The total