**Plastics — Determination of burning
behaviour by oxygen index —**

**Part 4:
High gas velocity test**

**iTeh STANDARD PREVIEW
(standards.iteh.ai)**

[ISO/PRF 4589-4](https://standards.iteh.ai/catalog/standards/sist/4f52f2bb-1671-47a5-bff8-cc99af05fcb/iso-prf-4589-4)

<https://standards.iteh.ai/catalog/standards/sist/4f52f2bb-1671-47a5-bff8-cc99af05fcb/iso-prf-4589-4>

PROOF / ÉPREUVE



iTeh STANDARD PREVIEW (standards.iteh.ai)

ISO/PRF 4589-4

<https://standards.iteh.ai/catalog/standards/sist/4f52f2bb-1671-47a5-bff8-cc99af05fcb/iso-prf-4589-4>



COPYRIGHT PROTECTED DOCUMENT

© ISO 2021

All rights reserved. Unless otherwise specified, or required in the context of its implementation, no part of this publication may be reproduced or utilized otherwise in any form or by any means, electronic or mechanical, including photocopying, or posting on the internet or an intranet, without prior written permission. Permission can be requested from either ISO at the address below or ISO's member body in the country of the requester.

ISO copyright office
CP 401 • Ch. de Blandonnet 8
CH-1214 Vernier, Geneva
Phone: +41 22 749 01 11
Email: copyright@iso.org
Website: www.iso.org

Published in Switzerland

Contents

	Page
Foreword.....	iv
Introduction.....	v
1 Scope.....	1
2 Normative references.....	1
3 Terms and definitions.....	1
4 Principles for determination of HOI.....	2
5 Apparatus.....	2
6 Calibration of equipment.....	7
7 Preparation of test specimens.....	7
7.1 Test specimen form.....	7
7.2 Sampling.....	8
7.3 Test specimen dimensions and preparation.....	8
7.4 Marking of test specimen.....	8
7.5 Conditioning.....	8
8 Procedure for determination of HOI.....	8
8.1 Setting up the apparatus.....	8
8.2 Setting volume fraction of oxygen and gas flow velocity.....	9
8.3 Procedure for ignition of the test specimen.....	9
8.4 Assessing the burning behaviour of test specimen.....	10
8.5 Selecting successive volume fraction of oxygen.....	10
8.6 Determining the preliminary volume fraction of oxygen.....	10
8.7 Volume fraction of oxygen changes.....	10
9 Calculation and expression of results.....	11
9.1 Calculation of the HOI.....	11
9.2 Determination of k	12
9.3 Standard deviation of oxygen volume fraction measurements.....	13
10 Precision of test results.....	13
11 Test report.....	13
Annex A (normative) Calibration of equipment.....	14
Annex B (informative) Example of test results sheet for HOI.....	15
Annex C (informative) Interlaboratory test data on HOI measurement.....	18
Annex D (informative) Blow-off behaviour at high gas velocity — How to predict the flammability of materials.....	20
Bibliography.....	29

Foreword

ISO (the International Organization for Standardization) is a worldwide federation of national standards bodies (ISO member bodies). The work of preparing International Standards is normally carried out through ISO technical committees. Each member body interested in a subject for which a technical committee has been established has the right to be represented on that committee. International organizations, governmental and non-governmental, in liaison with ISO, also take part in the work. ISO collaborates closely with the International Electrotechnical Commission (IEC) on all matters of electrotechnical standardization.

The procedures used to develop this document and those intended for its further maintenance are described in the ISO/IEC Directives, Part 1. In particular, the different approval criteria needed for the different types of ISO documents should be noted. This document was drafted in accordance with the editorial rules of the ISO/IEC Directives, Part 2 (see www.iso.org/directives).

Attention is drawn to the possibility that some of the elements of this document may be the subject of patent rights. ISO shall not be held responsible for identifying any or all such patent rights. Details of any patent rights identified during the development of the document will be in the Introduction and/or on the ISO list of patent declarations received (see www.iso.org/patents).

Any trade name used in this document is information given for the convenience of users and does not constitute an endorsement.

For an explanation of the voluntary nature of standards, the meaning of ISO specific terms and expressions related to conformity assessment, as well as information about ISO's adherence to the World Trade Organization (WTO) principles in the Technical Barriers to Trade (TBT), see www.iso.org/iso/foreword.html.

This document was prepared by Technical Committee ISO/TC 61, *Plastics*, Subcommittee SC 4, *Burning behaviour*.

<https://standards.iteh.ai/catalog/standards/sist/4f52f2bb-1671-47a5-bff8-99af05d4454c/iso-4589-4>

A list of all parts in the ISO 4589 series can be found on the ISO website.

Any feedback or questions on this document should be directed to the user's national standards body. A complete listing of these bodies can be found at www.iso.org/members.html.

Introduction

This document has been prepared to extend the test methods available for the determination of flammability by oxygen index to higher gas velocity of oxygen/nitrogen mixture to which plastic materials can be exposed in a service situation where the gas velocity is higher than that specified in ISO 4589-2. The gas velocity at the position of the test specimen is measured prior to the test.

The output of the test described in this document can be used, for example, in the evaluation of the burning behaviour of plastics materials used in circumstances where forced ventilation air flow governs the supply of oxygen to the fire. See References [10] to [16].

iTeh STANDARD PREVIEW (standards.iteh.ai)

[ISO/PRF 4589-4](https://standards.iteh.ai/catalog/standards/sist/4f52f2bb-1671-47a5-bff8-cc99af05fcb/iso-prf-4589-4)

<https://standards.iteh.ai/catalog/standards/sist/4f52f2bb-1671-47a5-bff8-cc99af05fcb/iso-prf-4589-4>

iTeh STANDARD PREVIEW
(standards.iteh.ai)

ISO/PRF 4589-4

<https://standards.iteh.ai/catalog/standards/sist/4f52f2bb-1671-47a5-bff8-cc99af05fcb/iso-prf-4589-4>

Plastics — Determination of burning behaviour by oxygen index —

Part 4: High gas velocity test

1 Scope

This document specifies a test method for determining the minimum volume fraction of oxygen, in admixture with nitrogen, at ambient temperature, that supports combustion of small vertical sheet test specimen under a specified gas velocity that is higher than that specified in ISO 4589-2.

NOTE The result is expressed as a high gas velocity oxygen index (HOI).

In addition, this document specifies the testing apparatus for determining the HOI.

The test method is applicable to materials in the form of sheets up to 2 mm thick. It is also applicable to flexible sheet materials that are supported vertically by a specified specimen holder.

2 Normative references

The following documents are referred to in the text in such a way that some or all of their content constitutes requirements of this document. For dated references, only the edition cited applies. For undated references, the latest edition of the referenced document (including any amendments) applies.

ISO 291:2008, *Plastics — Standard atmospheres for conditioning and testing*

ISO 2859-1, *Sampling procedures for inspection by attributes — Part 1: Sampling schemes indexed by acceptance quality limit (AQL) for lot-by-lot inspection*

ISO 2859-2, *Sampling procedures for inspection by attributes — Part 2: Sampling plans indexed by limiting quality (LQ) for isolated lot inspection*

ISO 13943, *Fire safety — Vocabulary*

3 Terms and definitions

For the purposes of this document, the terms and definitions given in ISO 13943, and the following apply.

ISO and IEC maintain terminological databases for use in standardization at the following addresses:

— ISO Online browsing platform: available at <https://www.iso.org/obp>

— IEC Electropedia: available at <http://www.electropedia.org/>

3.1

high gas velocity oxygen index

HOI

minimum volume fraction of oxygen, in a mixture of oxygen and nitrogen, at a specified gas velocity that supports flaming combustion of a material under specified test conditions

Note 1 to entry: The specified gas velocity is greater than 40 mm/s and is typically between 600 mm/s and 1 000 mm/s.

Note 2 to entry: The HOI is usually expressed as a percentage, at the gas velocity used (e.g. HOI = 34,6 %, 800 mm/s).

4 Principles for determination of HOI

A small test specimen is supported vertically in a mixture of oxygen and nitrogen that flows upwards through a transparent chimney. The volume fraction of oxygen in the gas mixture is pre-determined, controlled and measured. The vertical velocity of the gas mixture gas is pre-determined, controlled and measured. The upper end of the specimen is ignited, and its subsequent burning behaviour is observed in order to compare the burnt length of the specimen, with respect to the limits specified. The HOI is determined from a series of tests using different volume fractions of oxygen (see 8.7).

5 Apparatus

5.1 Test chimney, which shall consist of a heat-resistant glass tube supported vertically on a base through which the oxygen/nitrogen gas mixture can be introduced (see Figure 1).

The recommended dimensions of the chimney are 450 mm to 500 mm in height and an inside diameter of 75 mm to 100 mm. The upper outlet shall be open without any restriction.

NOTE It has been found that the outlet cup defined in ISO 4589-2:2017, 5.1 creates flow turbulence in the chimney at a high gas velocity.

A chimney having a height more than 500 mm or less than 450 mm can be used, if it is shown to give the specified gas velocity within the permitted limit of variance.

The lower end of the chimney, or the base upon which the chimney is supported, shall incorporate a device for evenly distributing the gas mixture entering the chimney as shown in Figure 1. The mounting of a porous screen below the level of the specimen holder is helpful to prevent falling combustion debris from fouling the gas entry and distribution paths. One option is to construct the chimney in such a way that it can be divided in half, so as to make the setting of samples and cleaning easier.

Dimension in millimetres

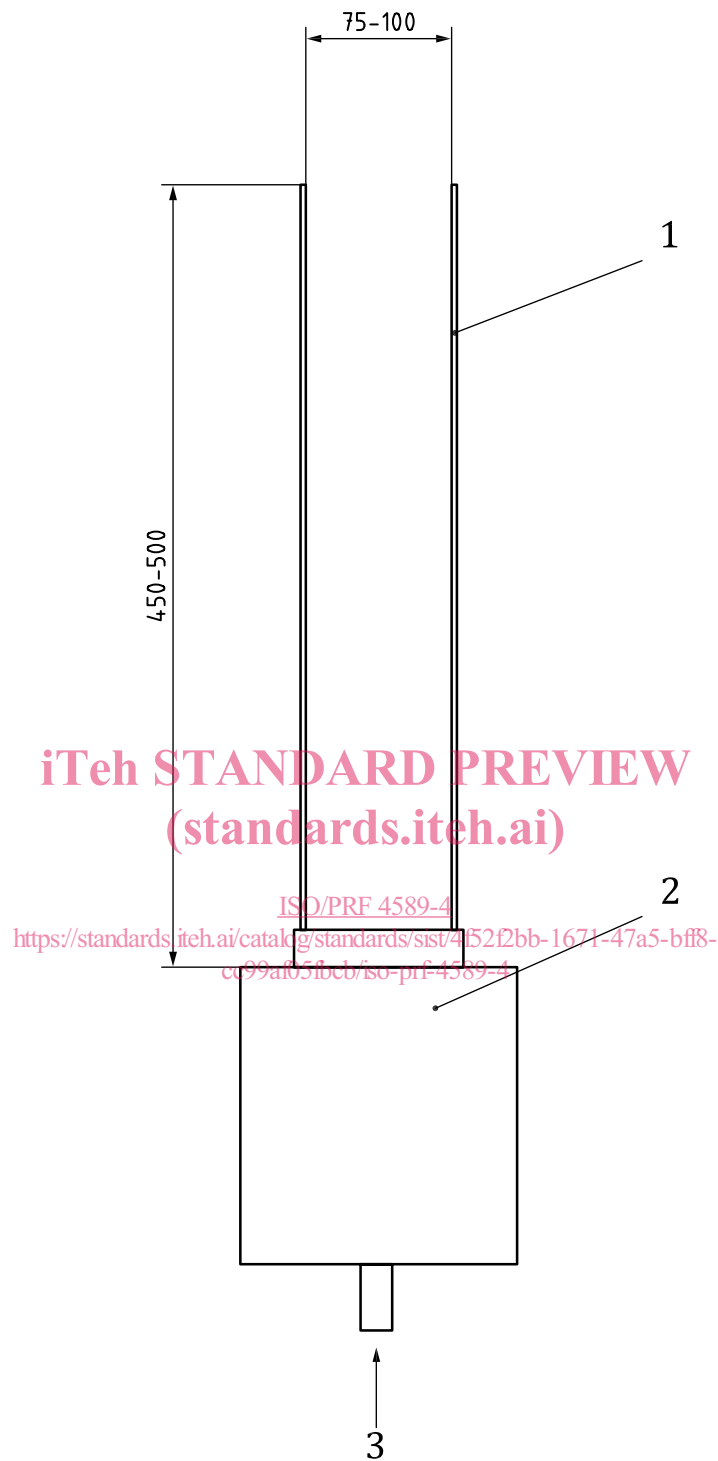

Key

- 1 chimney glass tube
- 2 gas flow controlling chamber
- 3 inlet of oxygen/nitrogen gas mixture

Figure 1 — Typical chimney arrangement

5.2 **Specimen holder**, which shall be suitable for supporting a specimen vertically in the centre of the chimney.

The specimen holder can be hanged from the upper edge of the chimney (see [Figure 2](#)) or supported by a vertical rod raised from the base of the chimney (see [Figure 3](#)). The specimen shall be supported by the vertical edges of the frames of the specimen holder. The vertical frames of the specimen holder shall have reference marks at 20 mm, 100 mm and 140 mm as shown in [Figure 2](#) and [Figure 3](#). The surfaces of the specimen holder and its support shall be smooth in order to minimize the turbulence of the gas flow in the chimney.

Dimensions in millimetres
with tolerances $\pm 0,25$ mm

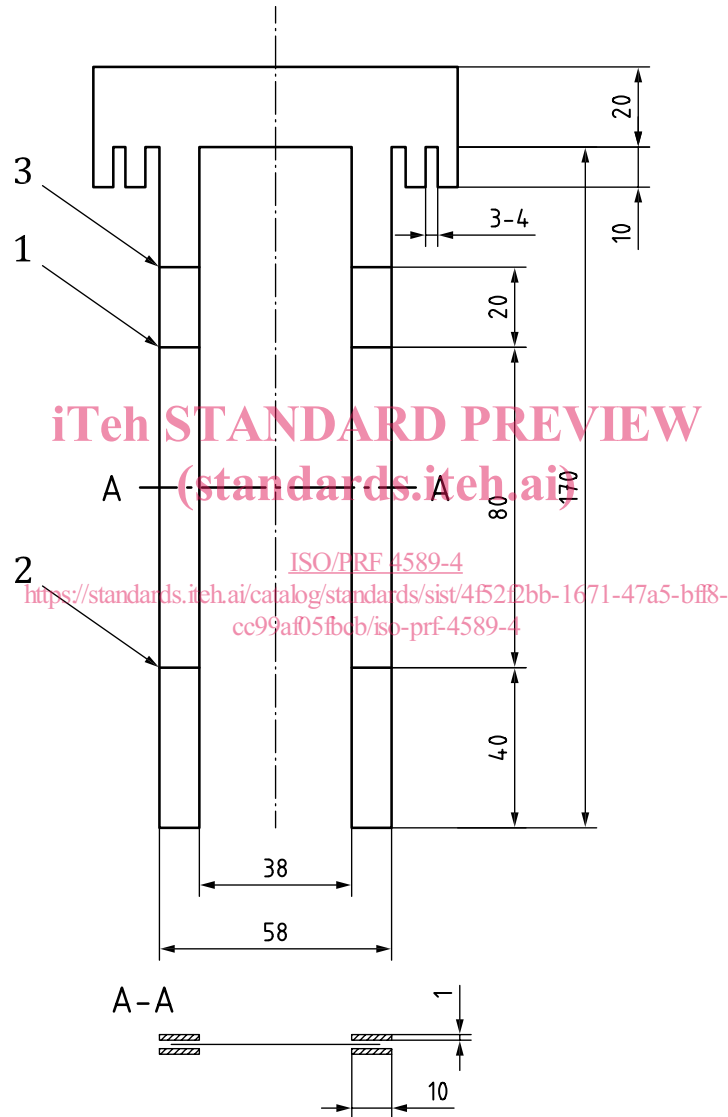

Key

- 1 upper reference mark
- 2 lower reference mark
- 3 positioning mark for the top edge of the test specimen

NOTE The test specimen is held securely along both upright edges between forks made of stainless steel.

**Figure 2 — Suspended specimen holder
(Option A hanging specimen holder)**

Dimensions in millimetres
with tolerances $\pm 0,25$ mm

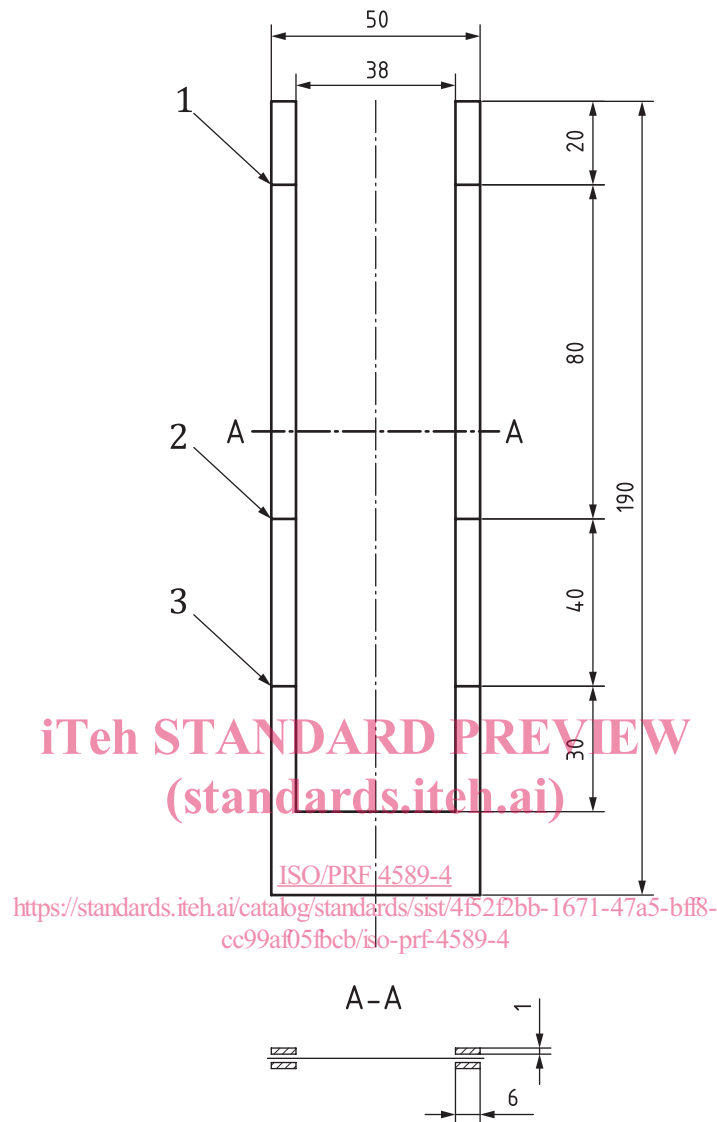

Key

- 1 upper reference mark
- 2 lower reference mark
- 3 positioning mark for the bottom edge of the test specimen

NOTE The test specimen is held securely along both upright edges between forks made of stainless steel.

**Figure 3 — Supported specimen holder
(Option B: Specimen holder supported from the bottom)**

5.3 Gas supplies, which shall be suitable for supporting an oxygen/nitrogen gas mixture with a gas velocity of up to 1 000 mm/s in the chimney. The gas velocity shall be within 50 mm/s of the desired value.

The supply rate of oxygen/nitrogen gas mixture in this document is greater than that specified in ISO 4589-2 and it is necessary to have higher gas supply capability than that for ISO 4589-2.

5.4 Gas control system, which shall be suitable for setting and adjusting the volume fraction of oxygen in a gas mixture entering into the chimney with a resolution of 0,1 % and an accuracy of $\pm 0,2$ % when the

gas velocity of the mixture within the chimney is $800 \text{ mm/s} \pm 50 \text{ mm/s}$ at $23 \text{ }^\circ\text{C} \pm 2 \text{ }^\circ\text{C}$. The gas velocity shall be controllable within the range of 600 mm/s to $1\ 000 \text{ mm/s}$.

The gas control system shall also be capable of supplying the oxygen/nitrogen gas mixture at the gas velocity of 100 mm/s or less for the ignition stage of the test (see 8.3).

Means shall be provided for ensuring that the temperature of the gas mixture entering into the chimney is $23 \text{ }^\circ\text{C} \pm 2 \text{ }^\circ\text{C}$. If such means involves an internal probe, its position and profile shall be designed to minimize the turbulence within the chimney.

NOTE It has been found that the temperature measurement can be done by a device specified in 5.9 and/or 5.10.

An example of the suitable gas control system is given in Figure 4.

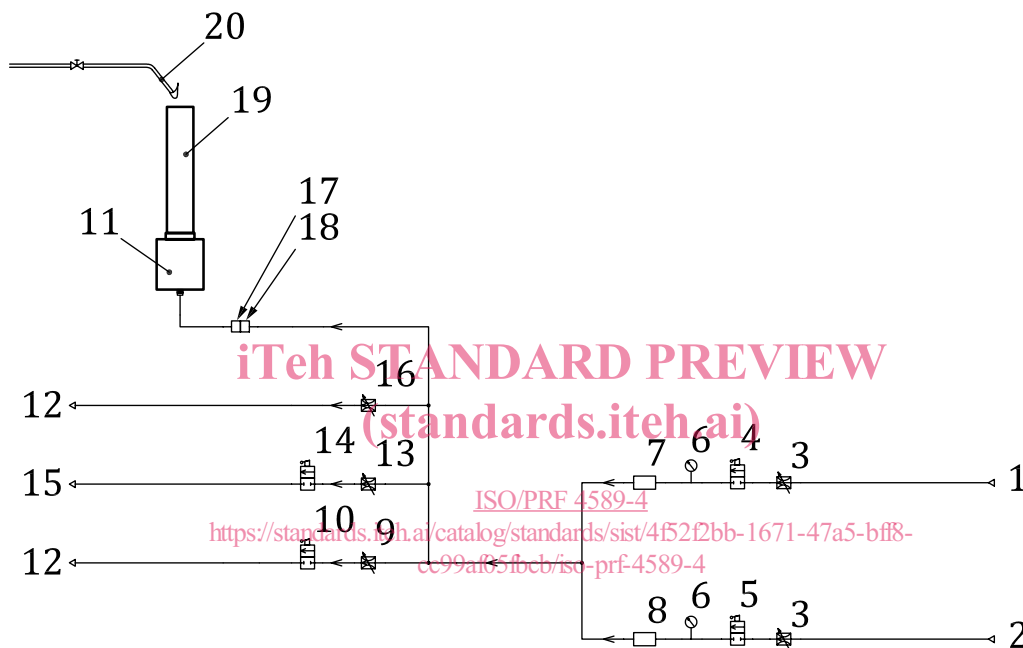

Key

- | | |
|--|---------------------------------|
| 1 N ₂ supply port | 11 gas flow controlling chamber |
| 2 O ₂ supply port | 12 bypass outlet |
| 3 pressure regulator | 13 flow rate control valve |
| 4 N ₂ supply valve | 14 open/shut valve |
| 5 O ₂ supply valve | 15 mixed gas sampling port |
| 6 pressure gauge | 16 flow rate control valve |
| 7 digital mass flow controller [for N ₂] | 17 coupler (plug) |
| 8 digital mass flow controller [for O ₂] | 18 coupler (socket) |
| 9 bypass flow rate control valve | 19 test chimney glass tube |
| 10 open/shut valve | 20 igniter |

Figure 4 — Example of diagram of gas control system

5.5 Oxygen analyser, which shall be suitable for measuring the volume fraction of oxygen in the gas mixture entering the chimney with a resolution of 0,1 % and an accuracy of $\pm 0,1 \%$ of the mixture.

NOTE 1 It has been found that paramagnetic oxygen analysers meet the accuracy requirements.

NOTE 2 In case the volume fraction of oxygen around the position of the specimen differs from that controlled at the air supply line, troubleshooting will be necessary.