**Dentistry — Endodontic
instruments —**

**Part 1:
General requirements**

Médecine bucco-dentaire — Instruments d'endodontie —

Partie 1: Exigences générales
iTeh STANDARD PREVIEW
(standards.iteh.ai)

[ISO 3630-1:2019](https://standards.iteh.ai/catalog/standards/sist/9e175b99-1057-4f54-a6e2-afa29f793f59/iso-3630-1-2019)

<https://standards.iteh.ai/catalog/standards/sist/9e175b99-1057-4f54-a6e2-afa29f793f59/iso-3630-1-2019>



iTeh STANDARD PREVIEW
(standards.iteh.ai)

ISO 3630-1:2019

<https://standards.iteh.ai/catalog/standards/sist/9e175b99-1057-4f54-a6e2-afa29f793f59/iso-3630-1-2019>



COPYRIGHT PROTECTED DOCUMENT

© ISO 2019

All rights reserved. Unless otherwise specified, or required in the context of its implementation, no part of this publication may be reproduced or utilized otherwise in any form or by any means, electronic or mechanical, including photocopying, or posting on the internet or an intranet, without prior written permission. Permission can be requested from either ISO at the address below or ISO's member body in the country of the requester.

ISO copyright office
CP 401 • Ch. de Blandonnet 8
CH-1214 Vernier, Geneva
Phone: +41 22 749 01 11
Fax: +41 22 749 09 47
Email: copyright@iso.org
Website: www.iso.org

Published in Switzerland

Contents

	Page
Foreword	v
Introduction	vi
1 Scope	1
2 Normative references	1
3 Terms and definitions	1
3.1 Terms and definitions.....	2
3.2 Symbols.....	3
4 Classification	3
5 Requirements	3
5.1 General.....	3
5.2 Type 1: Standard instruments.....	3
5.2.1 Length.....	3
5.2.2 Size designation and diameters.....	4
5.2.3 Colour designation.....	4
5.2.4 Tip shape.....	4
5.2.5 Tip length.....	5
5.3 Type 2: Taper instruments.....	5
5.3.1 Length.....	5
5.3.2 Tip shape.....	5
5.3.3 Size designation.....	6
5.3.4 Designation and diameters.....	6
5.3.5 Taper designation.....	6
5.3.6 Diameter colour identification.....	6
5.3.7 Taper colour and ring identification.....	7
5.4 Type 3: Non-taper instruments.....	7
5.4.1 Length.....	7
5.4.2 Size designation and diameters.....	7
5.4.3 Colour designation.....	7
5.5 Type 4: Non-uniform taper instruments.....	8
5.5.1 Length.....	8
5.5.2 Tip length and angle.....	8
5.5.3 Size designation.....	8
5.5.4 Diameter designation and diameters.....	8
5.5.5 Diameter colour identification.....	9
5.5.6 Taper colour and ring identification.....	9
5.6 Type 5: Shape instruments.....	9
5.6.1 Length.....	9
5.6.2 Size designation and diameters.....	9
5.6.3 Colour designation.....	9
5.7 Material.....	9
5.8 Dimensions.....	10
5.8.1 General.....	10
5.8.2 Length.....	10
5.8.3 Handle and shank.....	10
5.9 Mechanical requirements.....	11
5.9.1 Resistance to fracture by twisting and angular deflection.....	11
5.9.2 Stiffness (Resistance to bending).....	11
5.9.3 Handle and shank security.....	11
5.10 Reprocessing.....	12
6 Sampling	12
7 Measurement and test methods	12
7.1 Visual inspection.....	12

7.2	Test conditions.....	12
7.3	Measurement of dimensions.....	12
	7.3.1 Principle.....	12
	7.3.2 Measuring device.....	12
	7.3.3 Procedure.....	12
	7.3.4 Taper calculation.....	13
7.4	Resistance to fracture by twisting and angular deflection.....	13
	7.4.1 Principle.....	13
	7.4.2 Apparatus.....	13
	7.4.3 Procedure.....	14
	7.4.4 Expression of results.....	15
7.5	Stiffness.....	15
	7.5.1 Principle.....	15
	7.5.2 Apparatus.....	15
	7.5.3 Procedure.....	15
	7.5.4 Expression of results.....	16
7.6	Handle or shank security.....	16
	7.6.1 Principle.....	16
	7.6.2 Apparatus.....	16
	7.6.3 Preparation of test sample.....	16
	7.6.4 Procedure.....	16
7.7	Resistance to reprocessing.....	17
8	Designation, marking and identification.....	17
8.1	General.....	17
8.2	Identification symbols.....	17
9	Packaging.....	18
10	Instructions for use.....	18
11	Labeling.....	18
Bibliography	20

iTech STANDARD PREVIEW
(standards.iteh.ai)

[ISO 3630-1:2019](https://standards.iteh.ai/catalog/standards/sist/9e175b99-1057-4f54-a6e2-afa29f793f59/iso-3630-1-2019)

<https://standards.iteh.ai/catalog/standards/sist/9e175b99-1057-4f54-a6e2-afa29f793f59/iso-3630-1-2019>

Foreword

ISO (the International Organization for Standardization) is a worldwide federation of national standards bodies (ISO member bodies). The work of preparing International Standards is normally carried out through ISO technical committees. Each member body interested in a subject for which a technical committee has been established has the right to be represented on that committee. International organizations, governmental and non-governmental, in liaison with ISO, also take part in the work. ISO collaborates closely with the International Electrotechnical Commission (IEC) on all matters of electrotechnical standardization.

The procedures used to develop this document and those intended for its further maintenance are described in the ISO/IEC Directives, Part 1. In particular the different approval criteria needed for the different types of ISO documents should be noted. This document was drafted in accordance with the editorial rules of the ISO/IEC Directives, Part 2 (see www.iso.org/directives).

Attention is drawn to the possibility that some of the elements of this document may be the subject of patent rights. ISO shall not be held responsible for identifying any or all such patent rights. Details of any patent rights identified during the development of the document will be in the Introduction and/or on the ISO list of patent declarations received (see www.iso.org/patents).

Any trade name used in this document is information given for the convenience of users and does not constitute an endorsement.

For an explanation on the voluntary nature of standards, the meaning of ISO specific terms and expressions related to conformity assessment, as well as information about ISO's adherence to the World Trade Organization (WTO) principles in the Technical Barriers to Trade (TBT) see the following URL: www.iso.org/iso/foreword.html.

This document was prepared by Technical Committee ISO/TC 106, *Dentistry*, Subcommittee SC 4, *Dental instruments*.

This third edition cancels and replaces the second edition (ISO 3630-1:2008), which has been technically revised.

The main changes compared to the previous edition are as follows:

- reorganization with the intention of presenting the requirements and test methods for endodontic instruments in an orderly manner;
- change of the main element of the title of the ISO 3630 series to "Endodontic instruments";
- addition of requirements for the current use of Nickel-Titanium;
- clarification of the option for the handle shape for the manufacturer;
- addition of the new identification symbols in [Figure 10](#).

A list of all parts in the ISO 3630 series can be found on the ISO website.

Any feedback or questions on this document should be directed to the user's national standards body. A complete listing of these bodies can be found at www.iso.org/members.html.

Introduction

This document specifies general requirements and test methods for endodontic instruments. Other parts of the ISO 3630 series provide the specific requirements and test methods for six areas of endodontics (enlargers, compactors, auxiliary instruments, shaping and cleaning instruments, numeric coding system and ultrasonic inserts).

With current use of Nickel-Titanium alloys for manufacture of endodontic instruments a need for adequate expertise in their safe use is recommended. This document does not attempt to provide information for proper use of any instruments.

The sizes of the endodontic obturating points (cones) specified in ISO 6877 should be aligned with the corresponding sizes for endodontic instruments specified in all parts of the ISO 3630 series.

iTeh STANDARD PREVIEW (standards.iteh.ai)

[ISO 3630-1:2019](https://standards.iteh.ai/catalog/standards/sist/9e175b99-1057-4f54-a6e2-afa29f793f59/iso-3630-1-2019)

<https://standards.iteh.ai/catalog/standards/sist/9e175b99-1057-4f54-a6e2-afa29f793f59/iso-3630-1-2019>

Dentistry — Endodontic instruments —

Part 1: General requirements

1 Scope

This document specifies general requirements and test methods for endodontic instruments used for endodontic purposes, e.g. enlargers, compactors, accessory instruments, shaping and cleaning instruments, and a numeric coding system. In addition, it covers general size designations, color-coding, packaging, and identification symbols.

2 Normative references

The following documents are referred to in the text in such a way that some or all of their content constitutes requirements of this document. For dated references, only the edition cited applies. For undated references, the latest edition of the referenced document (including any amendments) applies.

ISO 554, *Standard atmospheres for conditioning and/or testing — Specifications*

ISO 1797, *Dentistry — Shanks for rotary and oscillating instruments*

ISO 1942, *Dentistry — Vocabulary*

ISO 3630-2, *Endodontic instruments — Part 2: Enlargers*

ISO 3630-3, *Endodontic instruments — Part 3: Compactors: pluggers and spreaders*

ISO 3630-4, *Root canal instruments — Part 4: Auxiliary instruments*

ISO 3630-5, *Endodontic instruments — Part 5: Shaping and cleaning instruments*

ISO 8601, *Data elements and interchange formats — Information interchange — Representation of dates and times*

ISO 15223-1:2016, *Medical devices — Symbols to be used with medical device labels, labelling and information to be supplied — Part 1: General requirements*

ISO 17664, *Processing of health care products — Information to be provided by the medical device manufacturer for the processing of medical devices*

3 Terms and definitions

For the purposes of this document, the terms and definitions given in ISO 1942 and the following apply.

ISO and IEC maintain terminological databases for use in standardization at the following addresses:

- ISO Online browsing platform: available at <https://www.iso.org/obp>
- IEC Electropedia: available at <http://www.electropedia.org/>

3.1 Terms and definitions

3.1.1

endodontic instrument

dental instrument designed to explore, shape, clean and/or help filling a root canal system

3.1.2

standard instrument

endodontic instrument (3.1.1) having a uniform taper of 0,02 mm per millimetre of length of the working part throughout the range of available sizes

Note 1 to entry: The nominal sizes of endodontic instruments are listed in [Table 1](#).

Note 2 to entry: Some manufacturers may designate taper as a 2-digit number, e.g. '02' or as a percentage, e.g. '2 %'.

3.1.3

non-standard instrument

endodontic instrument (3.1.1), which has a tip diameter and/or shape other than that of a *endodontic standard instrument* (3.1.2)

3.1.4

taper instrument

endodontic instrument (3.1.1) of which the sizes are determined by the tip sizes and have uniform tapers of the working part other than 0,02 mm per millimetre of length

3.1.5

non-taper instrument

endodontic instrument (3.1.1) having a cylindrical shape along its long axis

3.1.6

non-uniform taper instrument

endodontic instrument (3.1.1) having more than one taper along the working part

3.1.7

shape instrument

endodontic instrument (3.1.1) having a contoured working part with continuously varying profile

3.1.8

tip

part of the *endodontic instrument* (3.1.1), which is intended as the point, the shape of which is at the discretion of the manufacturer

3.1.9

working part

section of an *endodontic instrument* (3.1.1) which has a cutting surface

3.1.10

shaft

part of the *endodontic instrument* (3.1.1) between the handle or shank and the working part

3.1.11

handle

part of the *endodontic instrument* (3.1.1) which is held by the user's fingers for manipulation of the instrument in the root canal

3.1.12

shank

part of a rotary, oscillating or reciprocating *endodontic instrument* (3.1.1) which is designed to fit into the chuck of a handpiece

3.1.13**operative part**

part of the *endodontic instrument* (3.1.1) from the tip to the handle or shank

3.2 Symbols

For the purposes of this document, the following symbols apply.

- D diameter of the projection of the working part at the tip end (reference size)
- d_s diameter of the shank (the subscript indicates the location on the shank in s mm from the tip)
- d_n diameter of the *endodontic instrument* (3.1.1) at the subscripted millimetre distance from the tip indicated by [n]
EXAMPLE d_3 is the diameter at 3 mm from the tip.
- l_n length of the *endodontic instrument* (3.1.1) at the subscripted millimetre distance from the tip indicated by [n] and l_t .
EXAMPLE l_3 is the length 3 mm away from the tip.
- l_s minimum length of the shank
- l_t length of operative part, measured from the tip

iTeh STANDARD PREVIEW
(standards.iteh.ai)

4 Classification

For the purposes of this document, endodontic instruments are classified as follows:

Standard instrument [ISO 3630-1:2019](https://standards.iteh.ai/catalog/standards/sist/9e175b99-1057-4f54-a6e2-a629f793f59/iso-3630-1-2019)
<https://standards.iteh.ai/catalog/standards/sist/9e175b99-1057-4f54-a6e2-a629f793f59/iso-3630-1-2019>

— Type 1: standard instrument (taper = 02);

Non-standard instrument

- Type 2: taper instrument (taper other than 02);
Some manufacturers can designate taper as a percentage, e.g. '2 %'.
- Type 3: non-taper instrument (zero taper);
- Type 4: non-uniform taper instrument (more than one taper); and
- Type 5: shape instrument (arc shape).

5 Requirements**5.1 General**

Specific endodontic instrument types, such as enlargers, compactors and auxiliary instruments, have unique shapes, which are not included in this document. These instruments are covered in separate parts of the ISO 3630 series.

5.2 Type 1: Standard instruments**5.2.1 Length**

The length of the working part, l_{16} , shall be a minimum of 16 mm unless otherwise specified by the manufacturer (see [Figure 1](#)).

The length of the working part and length of the operative part shall be specified by the manufacturer, and shall be within $\pm 0,5$ mm of the specified length.

Test in accordance with 7.3.

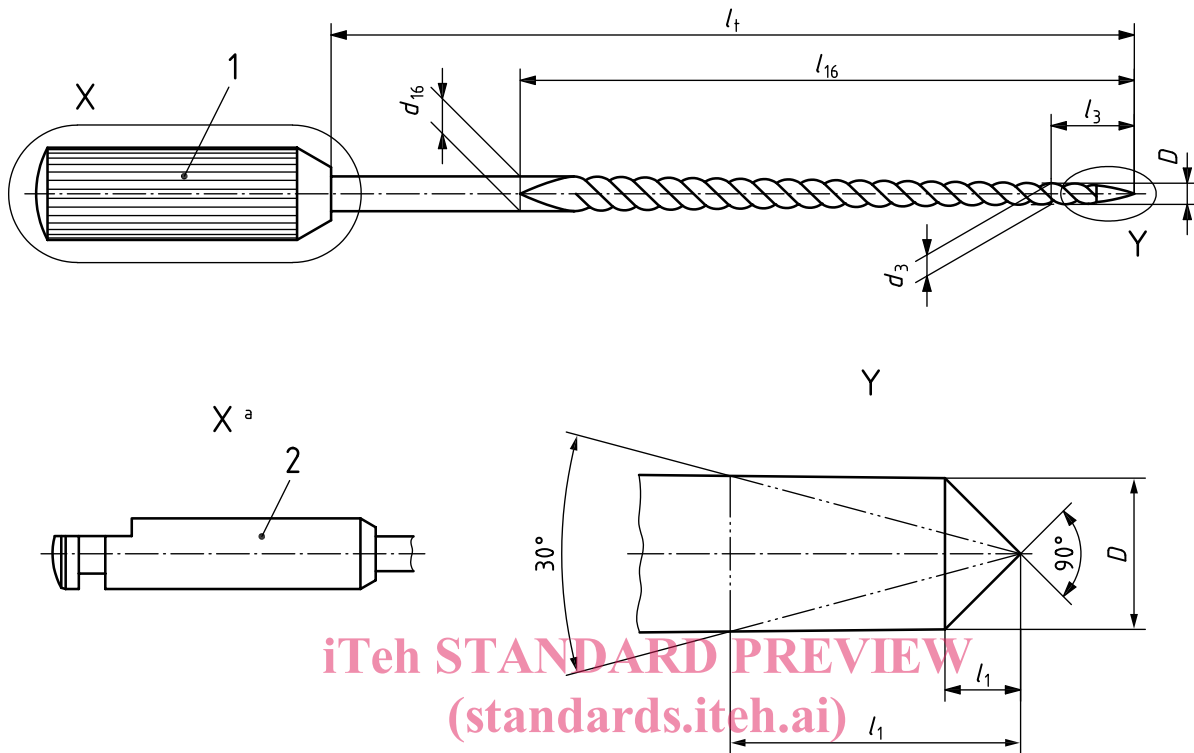

iTeh STANDARD PREVIEW
(standards.iteh.ai)

Key

- 1 handle
- 2 shank
- ^a Shape option for manufacturer.

ISO 3630-1:2019
<https://standards.iteh.ai/catalog/standards/sist/9e175b99-1057-4f54-a6e2-afa29f793f59/iso-3630-1-2019>

Figure 1 — Dimensions and locations for Type 1

5.2.2 Size designation and diameters

Table 1 gives the nominal sizes and dimensions for the working part to be used for Type 1 (standard instruments). Tip sizes (D) other than those listed in Table 1 are permitted. Figure 1 shows the position of the diameters and lengths for all Type 1 endodontic instruments. The nominal sizes shall correspond to the values of the extended diameters at the tip of the working part in hundredths of a millimetre.

5.2.3 Colour designation

The colour of the handle or shank of Type 1 instruments shall be in accordance with the requirements of Table 1.

NOTE The handle or shank colours of instrument sizes not included in Table 1 are at the discretion of the manufacturer.

5.2.4 Tip shape

The shape of the tip is at the discretion of the manufacturer. The angles shall be within 30° and 90°, as shown in the Figure 1.

**Table 1 — Dimensions, size designation, and colour designation for Type 1
(standard instruments)**

Dimensions in millimetres

Nominal size	D	d_3	Tolerance	d_{16}	Tolerance	l_3	l_{16}	Colour designation
6	0,06	0,12	±0,02	0,38	±0,02	3	16	pink
8	0,08	0,14		grey				
10	0,10	0,16		purple				
15	0,15	0,21		white				
20	0,20	0,26		yellow				
25	0,25	0,31		red				
30	0,30	0,36		blue				
35	0,35	0,41		green				
40	0,40	0,46		black				
45	0,45	0,51		white				
50	0,50	0,56		yellow				
55	0,55	0,61		red				
60	0,60	0,66		blue				
70	0,70	0,76		±0,04				1,02
80	0,80	0,86	1,12		black			
90	0,90	0,96	1,22		white			
100	1,00	1,06	1,32		yellow			
110	1,10	1,16	1,42		red			
120	1,20	1,26	1,52		blue			
130	1,30	1,36	1,62		green			
140	1,40	1,46	1,72		black			

5.2.5 Tip length

The tip length shall be specified by the manufacturer within the limits as shown in [Figure 1](#).

5.3 Type 2: Taper instruments

5.3.1 Length

The lengths of the working part and of the operative part shall be specified by the manufacturer, and shall be within ±0,5 mm of the specified lengths.

Test in accordance with [7.3](#).

5.3.2 Tip shape

The shape of the tip is at the discretion of the manufacturer. The angles shall be within 30° and 90° (see [Figure 1](#)).

The tip length is determined by the limits specified by the minimum and the maximum angle as shown in [Figure 1](#).