



Designation: D2444 – 99 (Reapproved 2010)

# Standard Test Method for Determination of the Impact Resistance of Thermoplastic Pipe and Fittings by Means of a Tup (Falling Weight)<sup>1</sup>

This standard is issued under the fixed designation D2444; the number immediately following the designation indicates the year of original adoption or, in the case of revision, the year of last revision. A number in parentheses indicates the year of last reapproval. A superscript epsilon ( $\epsilon$ ) indicates an editorial change since the last revision or reapproval.

*This standard has been approved for use by agencies of the U.S. Department of Defense.*

## 1. Scope

1.1 This test method covers the determination of the impact resistance of thermoplastic pipe and fittings under specified conditions of impact by means of a tup (falling weight). Three interchangeable striking noses are used on the tup, differing in geometrical configuration. Two specimen holders are described.

1.2 The values stated in inch-pound units are to be regarded as standard. The values given in parentheses are mathematical conversions to SI units that are provided for information only and are not considered standard.

1.3 *This standard does not purport to address all of the safety concerns, if any, associated with its use. It is the responsibility of the user of this standard to establish appropriate safety and health practices and determine the applicability of regulatory limitations prior to use.*

## 2. Referenced Documents

2.1 *ASTM Standards:*<sup>2</sup>

D618 Practice for Conditioning Plastics for Testing

D2122 Test Method for Determining Dimensions of Thermoplastic Pipe and Fittings

## 3. Significance and Use

3.1 The impact resistance of thermoplastic pipe and fittings relates to suitability for service and to quality of processing. Impact resistance may also provide a relative measure of a material's resistance to breakage during handling and installation and, for non-buried applications, to in-service breakage. See Appendix X4 for guidelines for selecting testing combinations.

<sup>1</sup> This test method is under the jurisdiction of ASTM Committee F17 on Plastic Piping Systems and is the direct responsibility of Subcommittee F17.40 on Test Methods.

Current edition approved Aug. 1, 2010. Published November 2010. Originally approved in 1965. Last previous edition approved in 2005 as D2444 – 99(2005). DOI: 10.1520/D2444-99R10.

<sup>2</sup> For referenced ASTM standards, visit the ASTM website, www.astm.org, or contact ASTM Customer Service at service@astm.org. For *Annual Book of ASTM Standards* volume information, refer to the standard's Document Summary page on the ASTM website.

3.2 Results obtained by use of this test method can be used in three ways:

3.2.1 As the basis for establishing impact test requirements in product standards,

3.2.2 To measure the effect of changes in materials or processing, and

3.2.3 To measure the effect of the environment.

## 4. Apparatus

4.1 *General*—One type of impact tester is illustrated in Fig. 1.

4.2 *Tup:*

4.2.1 The tup nose shall be as shown in Fig. 2. When used with the 0.50-in. (12.7-mm) radius nose, it is designated as Tup A. When used with the 2.00-in. (51-mm) radius nose, it is designated as Tup B. When used with the 0.25-in. (6.3-mm) radius nose, it is designated as Tup C.

NOTE 1—It is suggested that tups be made of scratch-resistant steel to reduce damage to the nose. Badly scarred noses may affect test results.

4.2.2 The mass of the tup shall be 6, 12, 20, or 30 lb (2.7, 5.4, 9.1, or 13.6 kg).

4.3 *Drop Tube:*

4.3.1 The drop tube shall be of sufficient length (approximately 12 ft (3.7 m)) to provide for a fall of at least 10 ft (3.0 m) and shall be mounted so that the lengthwise direction is vertical as measured with a plumb bob or a spirit level at least 2 ft (610 mm) in length.

4.3.2 Care must be taken to ensure that the tup falls freely; it must not “chatter” down the tube.

NOTE 2—No material for the drop tube is specified. However, a colddrawn seamless steel tubing with an inside diameter of  $2.563 \pm 0.003$  in. ( $65.10 \pm 0.08$  mm), or acrylonitrile-butadiene-styrene (ABS) or poly(vinyl chloride) (PVC) plastic pipe, 2½ in. nominal pipe size, with a standard dimension ratio (SDR) of 21, have been found to be satisfactory.

NOTE 3—Provided equivalent results are obtained, the tup may be dropped without a drop tube or guided by other means. The drop tube is used to reduce the hazard to operators and property that may occur when the tup rebounds. It also helps guide and center the tup so that it will be more likely to strike the top of the test specimen. It may also be necessary to provide a protective barrier around the specimen, particularly for larger sizes of pipe and fittings, to protect the operator from flying broken pieces.

NOTE 4—The tup may not fall freely if the clearance between the tup

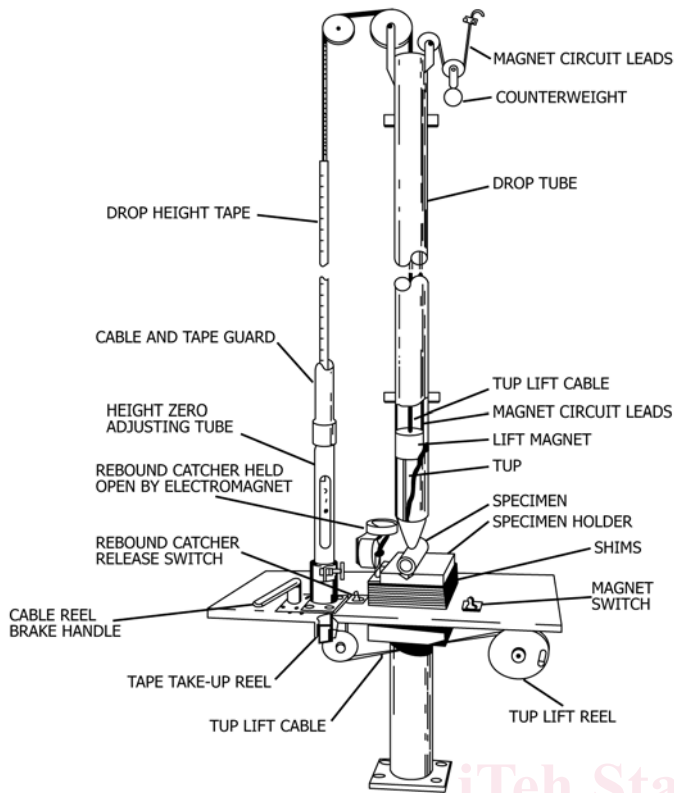
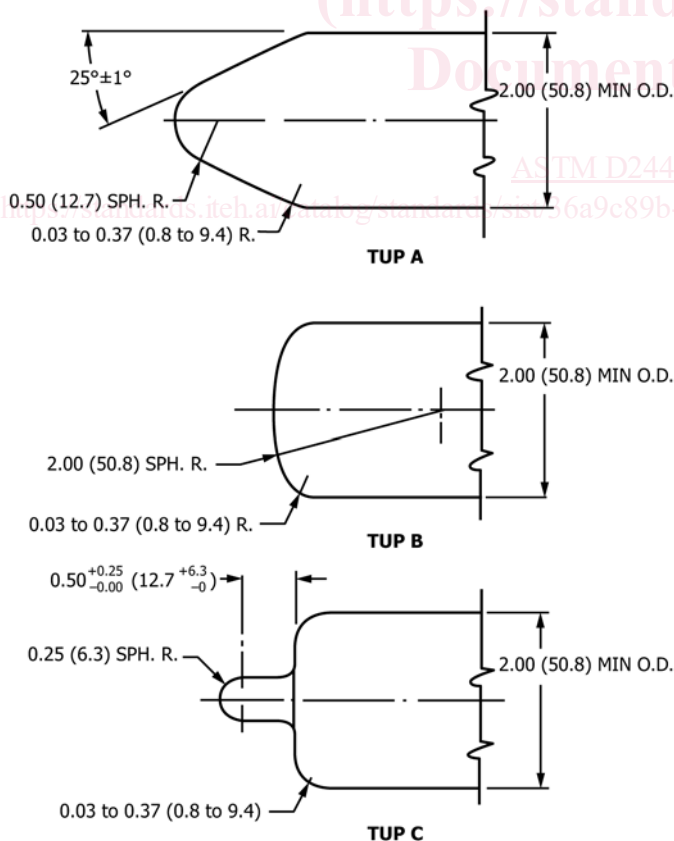

FIG. 1 One Type of Tup Impact Tester



NOTE 1—Dimensions are in inches (millimetres).

FIG. 2 Tup Nose Detail

and tube is too large or too small, or if it is restrained by a partial vacuum above the tup, such as can be caused by the hold and release device.

4.3.3 Means shall be provided (1) to hold the tup at steps of 2 in. (50.8 mm) for a distance of 2 to 10 ft (610 mm to 3.0 m) above the specimen holder, (2) to release the tup in a reproducible manner, (3) to allow the tup to fall freely, and (4) to catch the tup on the first rebound. Refer to Fig. 1.

4.4 *Specimen Holder*—Two specimen holders are described. The V-block (Holder A) is usually used with Tups A and C; the flat plate (Holder B) is often used with Tup B or for testing fittings.

4.4.1 The V-block holder shall be at least as long as the specimen being tested and shall have a 90-deg included angle. It may be fabricated or of solid construction. The side supports shall be of sufficient depth to support the specimen in the V and not on the top edges of the V-block.

NOTE 5—Both aluminum and steel have been found suitable for the holders.

4.4.2 The flat-plate holder shall consist of a plate approximately 8 by 12 by 1 in. (203 by 305 by 25.4 mm) in which a groove to position the pipe specimen shall be cut. This groove shall be about 0.12 in. (3 mm) in depth with the edges rounded to a radius of about 0.06 in. (1.5 mm). Fittings that do not contact the plate directly under the point of impact shall be supported at this point by a flat steel plate or shim. The specimen holder shall be mounted on a rigid base fastened to a concrete slab. Means shall be provided to center the specimens under the drop tube. A bar or rod placed inside the specimen and retained by a light spring may be employed if difficulty is encountered in holding the specimen in position.

## 5. Test Specimens

5.1 The pipe specimens shall be equal in length to the nominal outside diameter but not less than 6 in. (152 mm) in length. Burrs shall be removed.

5.2 Fittings shall be tested either unassembled or assembled to pieces of pipe each 6 in. in length.

## 6. Number of Test Specimens

6.1 A minimum of 20 specimens are required for preliminary tests.

6.2 A minimum of 100 specimens are required for final tests, and 50 additional specimens may be required.

## 7. Conditioning

7.1 Condition the test specimens at 40 h, 23°C, 50 % RH and 50 ± 5 % relative humidity for not less than 40 h prior to test in accordance with Procedure A of Practice D618, for those tests where conditioning is required.

7.2 *Test Conditions*—Conduct the test in a room maintained at the test temperature or, if the test is made in an atmosphere or at a temperature other than that at which the specimens are conditioned, conduct the test as soon as possible after removal from the conditioning atmosphere, but in any case within 15 s. In case of disagreement, conduct the tests in a room maintained at the test temperature.

## 8. Procedure—General

8.1 Measure the dimensions of the test specimens in accordance with Test Method [D2122](#).

8.2 The point of impact for all specimens shall be at the top of the vertical diameter.

8.3 Test unsymmetrical fittings with the specimen lying on its side.

8.4 Position the pipe specimens at random angular orientations.

8.5 Impact each specimen only once.

## 9. Procedure—Details

9.1 Impact one of the sets using an energy estimated to cause 15 % of the specimens to fail; impact the second set at an energy estimated to cause 85 % to fail. Record the actual percentage that fail and plot on normal probability graph paper.

### 9.2 Preliminary Tests:

9.2.1 The purpose of the preliminary tests is to identify the optimum tup mass and to determine the drop heights to be used for the final tests.

NOTE 6—The use of this preliminary procedure is optional. Trial and error, previous experience with the material, or guesswork may serve as well. Also, see [Appendix X3](#).

NOTE 7—The chief source of problems in conducting impact tests is the ratio of the standard deviation to the mean strength. Use of Tup C with pipe specimens will reduce the size of the problem.

9.2.2 Select a tup estimated to cause failure of some specimens when dropped from a height of 5 ft (1.5 m) and use it to test four specimens.

9.2.2.1 If at least one but not all four specimens fail with the first tup selected, continue the test as described in [9.2.3](#).

9.2.2.2 If all four specimens fail, test four more specimens with a lighter tup.

9.2.2.3 If all four specimens pass, test the same specimens with a heavier tup, at a drop height of 5 ft (1.5 m).

9.2.2.4 Once a weight has been used that results in the failure of some, but not all, specimens at a height of 5 ft (1.5 m), continue the test as described in [9.2.3](#). If no failures occur with the heaviest tup at a drop height of 5 ft (1.5 m), test at the maximum drop height. If no failures occur with the maximum weight at the maximum drop height, test a total of 50 specimens at this drop height, record the results, and discontinue testing. If one or more of the preliminary test specimens passes with the maximum weight at the maximum drop height, proceed to [9.2.3](#).

9.2.3 After the optimum tup weight has been determined, divide the remaining group of preliminary test specimens into two equal lots. Each group shall contain at least eight specimens. Test one lot at a lesser drop height so that substantially less than 50 % failures result. Test the second lot at a greater drop height so that substantially more than 50 % failures result. Plot these results on probability graph paper to serve as the basis for estimating the proper drop heights for the final test.

9.2.4 If the 6-lb (2.7-kg) tup produces 100 % failures at 5 ft (1.5 m), use lesser drop heights for the procedures outlined in [9.2.3](#).

NOTE 8—Because there must be both failures and nonfailures in this test, conditions that result in 100 % failures or 100 % passes are of limited value in the development of information. When all specimens pass, the problem can be helped by (1) changing from the flat-plate holder to the V-block holder (in the case of pipe specimens), (2) changing from Tup B to Tup A, and finally to Tup C, and (3) lowering the test temperature. When all specimens fail, the sequence is reversed.

### 9.3 Final Test:

9.3.1 Divide 100 test specimens into two equal sets.

9.3.2 On the basis of the preliminary test, trial and error, or judgment, estimate the drop height at which 85 % of the specimens will pass and test the first set of 50 specimens at this height. Record the value of the mass, the drop height, and the number of passes.

9.3.3 Estimate the drop height at which 85 % of the specimens will fail and, if it is 10 ft (3.0 m) or more, use this height. Test 50 specimens and record the number of passes and the drop height.

### 9.3.4 Acceptable Data:

9.3.4.1 To be acceptable, there must be at least one pass and at least one fail in each set of data; one set of data should list less than 50 % failures; the number of passes in the two sets should differ by at least 20.

9.3.4.2 If the requirements of [9.3.4.1](#) have not been met, test 50 additional specimens at a drop height chosen to rectify the deficiency.

9.3.5 Construct a straight-line plot of the test results on normal probability paper. Preliminary tests which were conducted at the same drop height as the final tests shall be used to compute the percent passing at that height. All other preliminary test results are ignored for purposes of obtaining the final plot.

9.3.6 The intercept of the plot with the 50 % pass/fail line is the average impact resistance of the set as measured by the test.

9.3.7 The intercept of the plot at the 16 % or the 84 % pass/fail line differs from the average strength by (for practical purposes) one standard deviation.

## 10. Definition of Failure

10.1 Failure in the test specimens shall be shattering or any crack or split created by the impact and that can be seen by the naked eye. Lighting devices may be used to assist in examining the specimens. A crease visible on the surface shall not be construed as failure. If criteria of failure other than those cited here are used, they shall be listed in the report.

## 11. Report

11.1 The report shall include the following:

11.1.1 Complete identification of pipe or fittings tested, including type of plastic, source, manufacturer's code, size, average dimensions and minimum wall thickness, and history,

11.1.2 In the case of fittings, the dimensions of pipe used to prepare the specimens, how joints were made, and the position of the weld mark in relation to the point of impact,

11.1.3 Test temperature and conditioning procedure,

11.1.4 Tup used,

11.1.5 Holder used,

11.1.6 The mass of the tup, lb (kg),

11.1.7 Point of impact for fittings,

- 11.1.8 Types of failure and any deformation observed,
- 11.1.9 Date of test, and
- 11.1.10 Copy of probability plot, including number of specimens tested at each drop height.

**12. Precision and Bias**

12.1 This test method is neither precise nor accurate within the limits usually associated with those terms unless larger

numbers of test specimens are employed. Therefore, no statement of bias can be made.

NOTE 9—A brief treatment of the subject of precision and accuracy for binomial tests is provided in **Appendix X1**.

**13. Keywords**

13.1 fittings; impact resistance; pipe; thermoplastic; tup (falling weight)

**APPENDIXES**

**(Nonmandatory Information)**

**X1. GUIDELINES FOR DETERMINING PRECISION AND ACCURACY BY APPLYING BINOMIAL PROBABILITY TECHNIQUES**

X1.1 Tests that have only two possible results (pass or fail, heads or tails, black or white) are governed by the rules of probability.

X1.2 The most elementary application of the rules occurs when the true probability of success is known. When a fair coin is tossed, for example, the probability for “heads” is known to be exactly 0.5 chance out of 1.

X1.3 The probability,  $P_n$ , for exactly  $r$  successes in  $n$  tries when the probability for success,  $p$ , is known for each try, is given by the equation

$$P_n = \frac{n!}{r!(n-r)!} (p^r) (1-p)^{n-r} \quad (X1.1)$$

*Example* — The chance that one will obtain exactly 25 heads when a fair coin is tossed 50 times is equal to

$$\frac{50!}{25!(50-25)!} (0.5^{25}) \text{ or } 0.112 \quad (X1.2)$$

The factorial of zero (0) is one (1).

X1.4 The total of the probabilities for all possible results is equal to 1. The equation is mathematically exact.

X1.5 A complication exists when the true probability of success is not known, but must be deduced on the basis of binomial test data. This is the case when thermoplastic pipe and fittings are subjected to impact testing as outlined in this test method.

X1.6 The binomial probability equation can be employed to define the likely limits of error for binomial test data. It will be simpler to refer to a statistics text or to use the approximate equation as follows:

$$s = \sqrt{\frac{p(1-p)}{N}} \quad (X1.3)$$

where:

$s$  = standard error,

$N$  = number of specimens tested, and  
 $p$  = measured rate of success.

*Example*—50 specimens are tested and 32 pass. Then the best estimate for  $p$  (true probability of success) is 0.64, and the standard error equals:

$$\sqrt{\frac{0.64(1-0.64)}{50}} = 0.07 \quad (X1.4)$$

The confidence level is 68.27 % (note the similarity to plus and minus one standard deviation); the true probability of success is in the range  $0.64 \pm 0.07$ , or from 0.57 to 0.71.

X1.7 The 90 % confidence interval is equal to the experimental value  $p$  plus and minus 1.65 standard errors, and the 95 % confidence interval is equal to the experimental value plus and minus 1.96 standard errors. Note that the foregoing deals with error due to probability only and does not take account of error caused by equipment or experimental technique.

X1.8 Charts defining the confidence limits for binomial test data are listed in many reference works. Dixon and Massey<sup>3</sup> provide charts for 80, 90, 95, and 99 % confidence coefficients.

X1.8.1 *Use of Fig. X1.1*—If 100 specimens are tested, and 24 pass, calculate  $p = 0.24$ . Find the ordinate labeled 0.24 at the bottom of the chart and read up. At the intersection with the first curved line labeled “100”, move to the left-hand side of the chart and read  $p' = 0.16$ . Return to the ordinate labeled 0.24 and find the intersection with the upper curved line labeled “100” and read “0.33” at the left-hand side of the chart. The probability of success ( $p'$ ) is identified as 0.16 to 0.33, to a 95 % confidence level.

*X1.9 Improving Accuracy:*

X1.9.1 This test method provides less accuracy than may be required for some purposes.

<sup>3</sup> Dixon, D. W., and Massey, Jr., F. J., “Introduction to Statistical Analysis,” 3rd ed., McGraw Hill Book Co., Inc. New York, NY, 1969, pp. 501–504.