



**SLOVENSKI STANDARD**  
**SIST EN 14972-5:2025**

**01-januar-2025**

---

**Vgrajeni gasilni sistemi - Sistemi s pršečo vodo - 5. del: Protokol preskušanja sistemov z avtomatskimi šobami za avtomobilske garaže**

Fixed firefighting systems - Water mist systems - Part 5: Test protocol for car garages for automatic nozzle systems

Ortsfeste Brandbekämpfungsanlagen - Wassernebelsysteme - Teil 5: Prüfprotokoll für Kfz-Garagen für automatische Düsensysteme

Installations fixes de lutte contre l'incendie - Systèmes à brouillard d'eau - Partie 5 : Protocole d'essai des systèmes à buses automatiques pour garages automobiles

**Ta slovenski standard je istoveten z: EN 14972-5:2024**

[SIST EN 14972-5:2025](https://standards.sist.net/catalog/standards/sist/69366110-403c-4c36-a212-1c7316515c72/sist-en-14972-5-2025)

<https://standards.sist.net/catalog/standards/sist/69366110-403c-4c36-a212-1c7316515c72/sist-en-14972-5-2025>

**ICS:**

13.220.10      Gašenje požara      Fire-fighting

**SIST EN 14972-5:2025**      **en,fr,de**



EUROPEAN STANDARD

EN 14972-5

NORME EUROPÉENNE

EUROPÄISCHE NORM

November 2024

ICS 13.220.20

English Version

## Fixed firefighting systems - Water mist systems - Part 5: Test protocol for car garages for automatic nozzle systems

Installations fixes de lutte contre l'incendie - Systèmes  
à brouillard d'eau - Partie 5 : Protocole d'essai des  
systèmes à buses automatiques pour parcs de  
stationnement

Ortsfeste Brandbekämpfungsanlagen -  
Wassernebelssysteme - Teil 5: Prüfprotokoll für Kfz-  
Garagen für automatische Düsensysteme

This European Standard was approved by CEN on 2 September 2024.

CEN members are bound to comply with the CEN/CENELEC Internal Regulations which stipulate the conditions for giving this European Standard the status of a national standard without any alteration. Up-to-date lists and bibliographical references concerning such national standards may be obtained on application to the CEN-CENELEC Management Centre or to any CEN member.

This European Standard exists in three official versions (English, French, German). A version in any other language made by translation under the responsibility of a CEN member into its own language and notified to the CEN-CENELEC Management Centre has the same status as the official versions.

CEN members are the national standards bodies of Austria, Belgium, Bulgaria, Croatia, Cyprus, Czech Republic, Denmark, Estonia, Finland, France, Germany, Greece, Hungary, Iceland, Ireland, Italy, Latvia, Lithuania, Luxembourg, Malta, Netherlands, Norway, Poland, Portugal, Republic of North Macedonia, Romania, Serbia, Slovakia, Slovenia, Spain, Sweden, Switzerland, Türkiye and United Kingdom.

[SIST EN 14972-5:2025](https://standards.iteh.ai/catalog/standards/sist/6056b1f0-a03e-4e56-a2f2-1c95f0545e72/sist-en-14972-5-2025)

<https://standards.iteh.ai/catalog/standards/sist/6056b1f0-a03e-4e56-a2f2-1c95f0545e72/sist-en-14972-5-2025>



EUROPEAN COMMITTEE FOR STANDARDIZATION  
COMITÉ EUROPÉEN DE NORMALISATION  
EUROPÄISCHES KOMITEE FÜR NORMUNG

CEN-CENELEC Management Centre: Rue de la Science 23, B-1040 Brussels

## Contents

	Page
European foreword .....	3
1 Scope.....	5
2 Normative references.....	5
3 Terms and definitions.....	5
4 General requirements.....	5
5 Car park garages fuel package .....	6
5.1 General.....	6
5.2 Vehicles.....	7
5.3 Conditioning of the fuel load.....	7
6 Reference sprinkler requirements.....	15
6.1 General.....	15
6.2 Reference sprinkler tests.....	15
7 Water mist system tests requirements.....	15
8 Test equipment requirements .....	16
9 Instrumentation requirements .....	16
9.1 General.....	16
9.2 Temperature.....	17
9.3 Pressure .....	17
9.4 Time.....	17
10 Testing criteria .....	17
10.1 General.....	17
10.2 Fire tests.....	17
10.3 Evaluation of test results.....	18
11 Test report.....	20

## European foreword

This document (EN 14972-5:2024) has been prepared by Technical Committee CEN/TC 191 “Fixed firefighting systems”, the secretariat of which is held by BSI.

This European Standard shall be given the status of a national standard, either by publication of an identical text or by endorsement, at the latest by May 2025, and conflicting national standards shall be withdrawn at the latest by May 2025.

Attention is drawn to the possibility that some of the elements of this document may be the subject of patent rights. CEN shall not be held responsible for identifying any or all such patent rights.

EN 14972, *Fixed firefighting systems — Water mist systems*, consists of the following parts:

- *Part 1: Design, installation, inspection and maintenance;*
- *Part 2: Test protocol for shopping areas for automatic nozzle systems;*
- *Part 3: Test protocol for office, school class rooms and hotel for automatic nozzle systems;*
- *Part 4: Test protocol for non-storage occupancies for automatic nozzle systems;*
- *Part 5: Test protocol for car garages for automatic nozzle systems;*
- *Part 6: Test protocol for false floors and false ceilings for automatic nozzle systems;*
- *Part 7: Test protocol for commercial low hazard occupancies for automatic nozzle systems;*
- *Part 8: Test protocol for machinery in enclosures exceeding 260 m<sup>3</sup> for open nozzle systems;*
- *Part 9: Test protocol for machinery in enclosures not exceeding 260 m<sup>3</sup> for open nozzle systems;*
- *Part 10: Test protocol for atrium protection with sidewall nozzles for open nozzle systems;*
- *Part 11: Test protocol for cable tunnels for open nozzle systems;*
- *Part 12: Test protocol for commercial deep fat cooking fryers for open nozzle systems;*
- *Part 13: Test protocol for wet benches and other similar processing equipment for open nozzle systems;*
- *Part 14: Test protocol for combustion turbines in enclosures exceeding 260 m<sup>3</sup> for open nozzle systems;*
- *Part 15: Test protocol for combustion turbines in enclosures not exceeding 260 m<sup>3</sup> for open nozzle systems;*
- *Part 16: Test protocol for industrial oil cookers for open nozzle systems*
- *Part 17: Test protocol for residential occupancies for automatic nozzle systems.*

NOTE This list includes standards that are in preparation and other standards might be added. For current status of published standards refer to [www.cencenelec.eu](http://www.cencenelec.eu).

Any feedback and questions on this document should be directed to the users’ national standards body. A complete listing of these bodies can be found on the CEN website.

**EN 14972-5:2024 (E)**

According to the CEN-CENELEC Internal Regulations, the national standards organisations of the following countries are bound to implement this European Standard: Austria, Belgium, Bulgaria, Croatia, Cyprus, Czech Republic, Denmark, Estonia, Finland, France, Germany, Greece, Hungary, Iceland, Ireland, Italy, Latvia, Lithuania, Luxembourg, Malta, Netherlands, Norway, Poland, Portugal, Republic of North Macedonia, Romania, Serbia, Slovakia, Slovenia, Spain, Sweden, Switzerland, Türkiye and the United Kingdom.

**iTeh Standards**  
**(<https://standards.iteh.ai>)**  
**Document Preview**

[SIST EN 14972-5:2025](https://standards.iteh.ai/catalog/standards/sist/6056b1f0-a03e-4e56-a2f2-1c95f0545e72/sist-en-14972-5-2025)

<https://standards.iteh.ai/catalog/standards/sist/6056b1f0-a03e-4e56-a2f2-1c95f0545e72/sist-en-14972-5-2025>

## 1 Scope

This document specifies the evaluation of the fire performance of water mist systems for non-stacking garages, fully enclosed garages and underground garages.

This document is applicable for horizontal, solid, flat ceilings with heights of 2 m and above.

## 2 Normative references

The following documents are referred to in the text in such a way that some or all of their content constitutes requirements of this document. For dated references, only the edition cited applies. For undated references, the latest edition of the referenced document (including any amendments) applies.

EN 12259-1, *Fixed firefighting systems — Components for sprinkler and water spray systems — Part 1: Sprinklers*

EN 12845, *Fixed firefighting systems — Automatic sprinkler systems — Design, installation and maintenance*

EN 14972-1, *Fixed firefighting systems — Water mist systems — Part 1: Design, installation, inspection and maintenance*

EN ISO/IEC 17025:2017, *General requirements for the competence of testing and calibration laboratories*

## 3 Terms and definitions

For the purposes of this document, the terms and definitions given in EN 14972-1 and the following apply.

ISO and IEC maintain terminology databases for use in standardization at the following addresses:

— ISO Online browsing platform: available at <https://www.iso.org/obp>

— IEC Electropedia: available at <https://www.electropedia.org/>

<https://standards.iteh.ai/catalog/standards/sist/6056b110-a03e-4e56-a2f2-1c95f0545e72/sist-en-14972-5-2025>

### 3.1

#### **car park garage**

enclosed area intended for car park with horizontal, solid, flat ceilings with heights of 2 m and above

Note 1 to entry: Automatic, stacking or non-fully enclosed are not covered by this definition.

## 4 General requirements

**4.1** The water mist system, operating without manual intervention, shall successfully complete all described performance fire tests for their specific applications.

**4.2** The water flow shall last for 30 min. Any remaining fire shall be manually extinguished and the fire damages shall be recorded.

**4.3** System components, component locations, operating conditions and test enclosure details shall remain unaltered throughout all of the fire tests for a given application.

**4.4** All fire tests should be conducted using the manufacturer instructions in regard to nozzle placement, spray flux, and spray duration. Sprays shall be continuous.

**4.5** The test protocol is only applicable to ceiling mounted pendent and upright automatic nozzles.

**EN 14972-5:2024 (E)**

**4.6** The nozzles shall be located in accordance with the manufacturer's instructions.

**4.7** Automatic nozzle thermal sensitivity shall be special or standard response as specified in EN 12259-1.

**4.8** The water supply shall be capable of supplying a flow rate and pressure according to the specific requirements, which are based on the actual layout of the pipework installation.

## 5 Car park garages fuel package

### 5.1 General

A relatively realistic car parking garages fuel package is employed in the test. As the fuel package is rather complex, the reference testing with a prescribed sprinkler system serves also to indicate the baseline performance at each different test facility and set-up. However, within one test series, the set of cars (selection of car 1, car 2, and car 3) shall be as identical as practicably possible for each test (i.e. make, type, number of doors), although car 1, car 2, and car 3 may differ from each other.

The test assembly to be provided for the tests shall comply with the following specifications and figures.

The test scenario is based on a car park garage, in which three vehicles are positioned as fire loads. Figure 1 shows the test assembly in accordance with the requirements specified in this clause.

The cars to be provided for testing shall have normal humidity as is achieved by indoor storage at  $(20 \pm 5) ^\circ\text{C}$ .

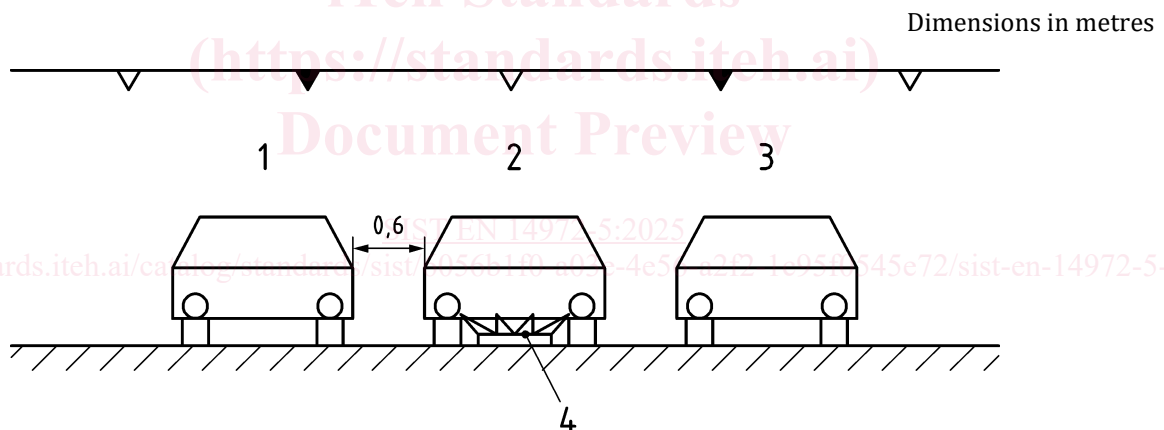

#### Key

- 1 car 1 (Target)
- 2 car 2
- 3 car 3 (Target)
- 4 fire pan
- ▽ sprinkler layout: below a sprinkler / automatic nozzle
- ▼ sprinkler layout: between 4 sprinklers / automatic nozzles

**Figure 1 — Assembly of fire loads and position of ignition source (side view)**



## 5.2 Vehicles

Three vehicles of the same type of construction shall be provided for the test assembly. It is necessary to use comparable vehicles in all tests. Especially the following parts of the vehicles used in the tests shall be comparable:

- vehicle dimension and type of construction (notchbacks, hatchback, estate);
- position of exterior plastic parts (exterior mirrors, decorative trimming elements);
- indicators on the sides underneath the exterior mirrors;
- bumpers (material; coated/not coated);
- fixed roof without openings (e.g. sun roof);
- spare wheel in the boot;
- upholstery and floor mats on the inside of the passenger compartment.

The vehicles provided shall be complete and undamaged. For safety reasons, all vehicles used in the test shall be prepared as follows prior to testing:

- all operating fluids, such as petrol or brake fluids, shall be discharged;
- the cap of the petrol tank shall be removed;
- the gas-filled shock absorbers in the boot lid shall be removed;
- airbags (where applicable) shall be removed;
- all tyres shall be depressurised (remove valve) and the vehicles shall be supported in order to ensure that the distance between the vehicle and the top of the floor remains the same during testing.

## 5.3 Conditioning of the fuel load

Ignition source shall be a fire pan, which shall be positioned under car 2 in accordance to Figure 2. The fire pan shall fulfil the following requirements:

- position: centrally (longitudinal and transverse axis) under car 2 with the longer side of the (combined) pan aligned with the length of the car;
- material: steel;
- dimensions:
  - 1 pan: 600 mm × 1 800 mm × 100 mm (regular);
  - 2 pans: 600 mm × 900 mm × 100 mm (alternative);
- total amount of fuel: 14 l heptane + 14 l water.

## EN 14972-5:2024 (E)

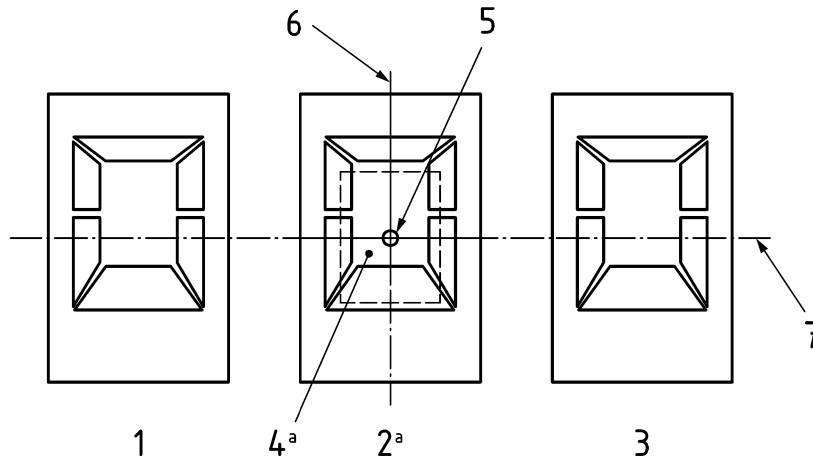
**Key**

1	car 1	5	centre sprinkler U1 scenario
2	car 2	6	longitudinal axis
3	car 3	7	transverse axis
4	fire pan	a	centred under centre sprinkler U1

**Figure 2 — Assembly of fire loads and position of ignition source (top view)**

Figures 2 to 8 exemplify the test layout with a minimum ceiling area of (11 × 11) m.

(<https://standards.iteh.ai>)  
Document Preview

[SIST EN 14972-5:2025](https://standards.iteh.ai/catalog/standards/sist/6056b1f0-a03e-4e56-a2f2-1c95f0545e72/sist-en-14972-5-2025)

<https://standards.iteh.ai/catalog/standards/sist/6056b1f0-a03e-4e56-a2f2-1c95f0545e72/sist-en-14972-5-2025>