



Designation: ~~D5961/D5961M-08~~ Designation: D5961/D5961M – 10

Standard Test Method for Bearing Response of Polymer Matrix Composite Laminates¹

This standard is issued under the fixed designation D5961/D5961M; the number immediately following the designation indicates the year of original adoption or, in the case of revision, the year of last revision. A number in parentheses indicates the year of last reapproval. A superscript epsilon (ϵ) indicates an editorial change since the last revision or reapproval.

1. Scope

1.1 This test method covers the bearing response of pinned or fastened joints using multi-directional polymer matrix composite laminates reinforced by high-modulus fibers by double-shear tensile loading (Procedure A), single-shear tensile or compressive loading of a two-piece specimen (Procedure B), single-shear tensile loading of a one-piece specimen (Procedure C), or double-shear compressive loading (Procedure D). Standard specimen configurations using fixed values of test parameters are described for each procedure. However, when fully documented in the test report, a number of test parameters may be optionally varied. The composite material forms are limited to continuous-fiber or discontinuous-fiber (tape or fabric, or both) reinforced composites for which the laminate is balanced and symmetric with respect to the test direction. The range of acceptable test laminates and thicknesses are described in 8.2.1.

1.2 This test method is consistent with the recommendations of MIL-HDBK-17, which describes the desirable attributes of a bearing response test method.

1.3 The multi-fastener test configurations described in this test method are similar to those used by industry to investigate the bypass portion of the bearing bypass interaction response for bolted joints, where the specimen may produce either a bearing failure mode or a bypass failure mode. Note that the scope of this test method is limited to bearing and fastener failure modes. Use Test Method D7248/D7248M for by-pass testing.

1.4 The values stated in either SI units or inch-pound units are to be regarded separately as standard. ~~Within the text the inch-pound units are shown in brackets.~~ The values stated in each system are may not be exact equivalents; therefore, each system ~~must~~ shall be used independently of the other. Combining values from the two systems may result in non-conformance with the standard.

1.4.1 Within the text the inch-pound units are shown in brackets.

1.5 *This standard does not purport to address all of the safety concerns, if any, associated with its use. It is the responsibility of the user of this standard to establish appropriate safety and health practices and determine the applicability of regulatory limitations prior to use.*

2. Referenced Documents

2.1 *ASTM Standards:*²

D792 Test Methods for Density and Specific Gravity (Relative Density) of Plastics by Displacement

D883 Terminology Relating to Plastics

D953 Test Method for Bearing Strength of Plastics

D2584 Test Method for Ignition Loss of Cured Reinforced Resins

D2734 Test Methods for Void Content of Reinforced Plastics

D3171 Test Methods for Constituent Content of Composite Materials

D3410/D3410M Test Method for Compressive Properties of Polymer Matrix Composite Materials with Unsupported Gage Section by Shear Loading

D3878 Terminology for Composite Materials

D5229/D5229M Test Method for Moisture Absorption Properties and Equilibrium Conditioning of Polymer Matrix Composite Materials

D5687/D5687M Guide for Preparation of Flat Composite Panels with Processing Guidelines for Specimen Preparation

¹ This test method is under the jurisdiction of ASTM Committee D30 on Composite Materials and is the direct responsibility of Subcommittee D30.05 on Structural Test Methods.

Current edition approved Sept. 15, 2008. Published November 2008. Originally approved in 1996. Last previous edition approved in 2005 as D5961/D5961M-05^ε. DOI: 10.1520/D5961-D5961M-08.

Current edition approved Oct. 1, 2010. Published November 2010. Originally approved in 1996. Last previous edition approved in 2008 as D5961/D5961M-08. DOI: 10.1520/D5961-D5961M-10.

² For referenced ASTM standards, visit the ASTM website, www.astm.org, or contact ASTM Customer Service at service@astm.org. For *Annual Book of ASTM Standards* volume information, refer to the standard's Document Summary page on the ASTM website.

D7248/D7248M Test Method for Bearing/Bypass Interaction Response of Polymer Matrix Composite Laminates Using 2-Fastener Specimens

E4 Practices for Force Verification of Testing Machines

E6 Terminology Relating to Methods of Mechanical Testing

E83 Practice for Verification and Classification of Extensometer Systems

E122 Practice for Calculating Sample Size to Estimate, With Specified Precision, the Average for a Characteristic of a Lot or Process

E177 Practice for Use of the Terms Precision and Bias in ASTM Test Methods

E238 Test Method for Pin-Type Bearing Test of Metallic Materials

E456 Terminology Relating to Quality and Statistics

E691 Practice for Conducting an Interlaboratory Study to Determine the Precision of a Test Method

E1309 Guide for Identification of Fiber-Reinforced Polymer-Matrix Composite Materials in Databases

E1434 Guide for Recording Mechanical Test Data of Fiber-Reinforced Composite Materials in Databases

E1471 Guide for Identification of Fibers, Fillers, and Core Materials in Computerized Material Property Databases

2.2 *Other Document:*

MIL-HDBK-17, *Polymer Matrix Composites*, Vol 1, Section 7³

3. Terminology

3.1 *Definitions*—Terminology D3878 defines terms relating to high-modulus fibers and their composites. Terminology D883 defines terms relating to plastics. Terminology E6 defines terms relating to mechanical testing. Terminology E456 and Practice E177 define terms relating to statistics. In the event of a conflict between terms, Terminology D3878 shall have precedence over the other documents.

NOTE 1—If the term represents a physical quantity, its analytical dimensions are stated immediately following the term (or letter symbol) in fundamental dimension form, using the following ASTM standard symbology for fundamental dimensions, shown within square brackets: $[M]$ for mass, $[L]$ for length, $[T]$ for time, $[I]$ for thermodynamic temperature, and $[nd]$ for nondimensional quantities. Use of these symbols is restricted to analytical dimensions when used with square brackets, as the symbols may have other definitions when used without the brackets.

3.2 *Definitions of Terms Specific to This Standard:*

3.2.1 *bearing area*, $[L^2]$, n —the area of that portion of a bearing specimen used to normalize applied loading into an effective bearing stress; equal to the diameter of the loaded hole multiplied by the thickness of the specimen.

3.2.2 *bearing chord stiffness*, $E^{br} [ML^{-1}T^{-2}]$, n —the chord stiffness between two specific bearing stress or bearing strain points in the linear portion of the bearing stress/bearing strain curve.

3.2.3 *bearing force*, $P [MLT^2]$, n —the total force carried by a bearing specimen.

3.2.4 *bearing strain*, $\epsilon^{br} [nd]$, n —the normalized hole deformation in a bearing specimen, equal to the deformation of the bearing hole in the direction of the bearing force, divided by the diameter of the hole.

3.2.5 *bearing strength*, $F_x^{br} [ML^{-1}T^{-2}]$, n —the value of bearing stress occurring at a significant event on the bearing stress/bearing strain curve.

3.2.5.1 *Discussion*—Two types of bearing strengths are commonly identified, and noted by an additional superscript: offset strength and ultimate strength.

3.2.6 *bearing stress*, $F^{br} [ML^{-1}T^{-2}]$, n —the bearing force divided by the bearing area.

3.2.7 *countersink depth to thickness ratio*, $d_{csk}/h [nd]$,—the ratio of the countersunk depth of a hole to the specimen thickness.

3.2.7.1 *Discussion*—The countersink depth to thickness ratio is typically a nominal value determined from nominal hole-drilling dimensions and tolerances.

3.2.8 *diameter to thickness ratio*, $D/h [nd]$, n —in a bearing specimen, the ratio of the hole diameter to the specimen thickness.

3.2.8.1 *Discussion*—The diameter to thickness ratio may be either a nominal value determined from nominal dimensions or an actual value determined from measured dimensions.

3.2.9 *edge distance ratio*, $e/D [nd]$, n —in a bearing specimen, the ratio of the distance between the center of the hole and the specimen end to the hole diameter.

3.2.9.1 *Discussion*—The edge distance ratio may be either a nominal value determined from nominal dimensions or an actual value determined from measured dimensions.

3.2.10 *nominal value*, n —a value, existing in name only, assigned to a measurable quantity for the purpose of convenient designation. Tolerances may be applied to a nominal value to define an acceptable range for the quantity.

3.2.11 *offset bearing strength*, $F_x^{bro} [ML^{-1}T^{-2}]$, n —the value of bearing stress, in the direction specified by the subscript, at the point where a bearing chord stiffness line, offset along the bearing strain axis by a specified bearing strain value, intersects the bearing stress/bearing strain curve.

3.2.11.1 *Discussion*—Unless otherwise specified, an offset bearing strain of 2 % is to be used in this test method.

³ Available from Standardization Documents Order Desk, DODSSP, Bldg. 4, Section D, 700 Robbins Ave., Philadelphia, PA 19111-5098, <http://dodssp.daps.dla.mil>.

3.2.12 *width to diameter ratio, w/D [nd], n —in a bearing specimen, the ratio of specimen width to hole diameter.*

3.2.12.1 *Discussion*—The width to diameter ratio may be either a nominal value determined from nominal dimensions or an actual value, determined as the ratio of the actual specimen width to the actual hole diameter.

3.2.13 *ultimate bearing strength, F_x^{bru} [$ML^{-1}T^{-2}$], n —the value of bearing stress, in the direction specified by the subscript, at the maximum force capability of a bearing specimen.*

3.3 *Symbols:*

A = minimum cross-sectional area of a specimen

CV = coefficient of variation statistic of a sample population for a given property (in percent)

d = fastener or pin diameter

D = specimen hole diameter

d_{csk} = countersink depth

$d_{\bar{n}}$ = countersink flushness (depth or protrusion of the fastener in a countersunk hole)

e = distance, parallel to force, from hole center to end of specimen; the edge distance

E_x^{br} = ~~bearing chord stiffness in the test direction specified by the subscript~~ *bearing chord stiffness in the test direction specified by the subscript (for determination of offset bearing strength)*

f = distance, parallel to force, from hole edge to end of specimen

F_x^{bru} = ultimate bearing strength in the test direction specified by the subscript

F_x^{bro} (e %) = offset bearing strength (at e % bearing strain offset) in the test direction specified by the subscript

g = distance, perpendicular to force, from hole edge to shortest edge of specimen

h = specimen thickness

k = calculation factor used in bearing equations to distinguish single-fastener tests from double-fastener tests

K = calculation factor used in bearing equations to distinguish single-shear tests from double-shear tests in a single bearing strain equation

L_g = extensometer gage length

n = number of specimens per sample population

P = force carried by test specimen

P^f = force carried by test specimen at failure

P^{max} = maximum force carried by test specimen prior to failure

s_{n-1} = standard deviation statistic of a sample population for a given property

w = specimen width

x_i = test result for an individual specimen from the sample population for a given property

\bar{x} = mean or average (estimate of mean) of a sample population for a given property

δ = extensional displacement

ϵ = general symbol for strain, whether normal strain or shear strain

ϵ^{br} = bearing strain

σ^{br} = bearing stress

4. Summary of Test Method

4.1 Procedure A, Double Shear, Tension:

4.1.1 A flat, constant rectangular cross-section test specimen with a centerline hole located near the end of the specimen, as shown in the test specimen drawings of Figs. 1 and 2, is loaded at the hole in bearing. The bearing force is normally applied through a close-tolerance, lightly torqued fastener (or pin) that is reacted in double shear by a fixture similar to that shown in Figs. 3 and 4. The bearing force is created by loading the assembly in tension in a testing machine.

4.1.2 Both the applied force and the associated deformation of the hole are monitored. The hole deformation is normalized by the hole diameter to create an effective bearing strain. Likewise, the applied force is normalized by the projected hole area to create an effective bearing stress. The specimen is loaded until a maximum force has clearly been reached, whereupon the test is terminated so as to prevent masking of the true failure mode by large-scale hole distortion, in order to provide a more representative failure mode assessment. Bearing stress versus bearing strain for the entire loading regime is plotted, and failure mode noted. The ultimate bearing strength of the material is determined from the maximum force carried prior to test termination.

4.1.3 The standard test configuration for this procedure does not allow any variation of the major test parameters. However, the following variations in specimen and test fixture configuration are allowed, but can be considered as being in accordance with this test method only as long as the values of all variant test parameters are prominently documented with the results:

DRAWING NOTES:

1. INTERPRET DRAWING IN ACCORDANCE WITH ANSI Y14.5M-1982, SUBJECT TO THE FOLLOWING:
2. ALL DIMENSIONS IN MILLIMETRES WITH DECIMAL TOLERANCES AS FOLLOWS:

NO DECIMAL	.X	.XX
± 1	± 0.3	± 0.1
3. ALL ANGLES HAVE TOLERANCE OF $\pm .5^\circ$.
4. PLY ORIENTATION DIRECTION TOLERANCE RELATIVE TO \square -A- IS RECOMMENDED TO BE WITHIN $\pm .5^\circ$. (See Section 6.1.)
5. FINISH ON MACHINED EDGES NOT TO EXCEED $1.6\sqrt{\quad}$ (SYMBOLY IN ACCORDANCE WITH ASA B46.1, WITH ROUGHNESS HEIGHT IN MICROMETRES.)
6. VALUES TO BE PROVIDED FOR THE FOLLOWING, SUBJECT TO ANY RANGES SHOWN ON THE FIELD OF DRAWING: MATERIAL, LAY-UP, PLY ORIENTATION REFERENCE RELATIVE TO \square -A-, OVERALL LENGTH, HOLE DIAMETER, AND COUPON THICKNESS
7. FOR PROCEDURE D, REDUCE LENGTH, L, AS REQUIRED IN ORDER TO PREVENT BUCKLING

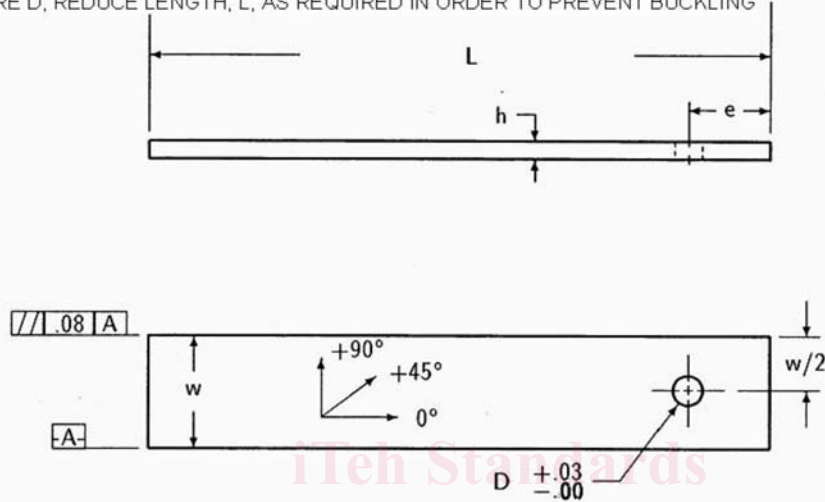

Parameter	Standard Dimension, mm
fastener or pin diameter, d	6 +0.00/-0.03
hole diameter, D	6 +0.03/-0.00
thickness range, h	3-5
length, L	135
width, w	36 \pm 1
edge distance, e	18 \pm 1
countersink	none

FIG. 1 Double-Shear and Single-Shear One-Piece Test Specimen Drawing (SI)

Parameter	Standard	Variation
Loading condition:	double-shear	none
Mating material:	steel fixture	none
Number of holes:	1	none
Countersink:	none	none
Fit:	tight	any, if documented
Fastener torque:	2.2-3.4 N-m [20-30 lbf-in.]	any, if documented
Laminate:	quasi-isotropic	any, if documented
Fastener diameter:	6 mm [0.250 in.]	any, if documented
Edge distance ratio:	3	any, if documented
w/D ratio:	6	any, if documented
D/h ratio:	1.2-2	any, if documented

4.2 Procedure B, Single Shear, Two-Piece Specimen:

4.2.1 The flat, constant rectangular cross-section test specimen is composed of two like halves fastened together through one or two centerline holes located near one end of each half, as shown in the test specimen drawings of Figs. 5-8. The eccentricity in applied force that would otherwise result is minimized by a doubler bonded to, or frictionally retained against each grip end of the specimen, resulting in a force line-of-action along the interface between the specimen halves, through the centerline of the hole(s).

4.2.1.1 *Unstabilized Configuration (No Support Fixture)*—The ends of the test specimen are gripped in the jaws of a test machine and loaded in tension.

4.2.1.2 *Stabilized Configuration (Using Support Fixture)*—The test specimen is face-supported in a multi-piece bolted support fixture, similar to that shown in Fig. 9. The test specimen/fixture assembly is clamped in hydraulic wedge grips and the force is sheared into the support fixture and then sheared into the specimen. The stabilized configuration is primarily intended for

DRAWING NOTES:

1. INTERPRET DRAWING IN ACCORDANCE WITH ANSI Y14.5M-1982, SUBJECT TO THE FOLLOWING:
2. ALL DIMENSIONS IN INCHES WITH DECIMAL TOLERANCES AS FOLLOWS:

.X	.XX	.XXX
± .1	± .03	± .01
3. ALL ANGLES HAVE TOLERANCE OF ± .5°.
4. PLY ORIENTATION DIRECTION TOLERANCE RELATIVE TO [-A-] IS RECOMMENDED TO BE WITHIN ± .5°. (See Section 6.1.)
5. FINISH ON MACHINED EDGES NOT TO EXCEED 64√ (SYMBOLY IN ACCORDANCE WITH ASA B46.1, WITH ROUGHNESS HEIGHT IN MICROINCHES.)
6. VALUES TO BE PROVIDED FOR THE FOLLOWING, SUBJECT TO ANY RANGES SHOWN ON THE FIELD OF DRAWING: MATERIAL, LAY-UP, PLY ORIENTATION REFERENCE RELATIVE TO [-A-], OVERALL LENGTH, HOLE DIAMETER, AND COUPON THICKNESS.
7. FOR PROCEDURE D, REDUCE LENGTH, L, AS REQUIRED IN ORDER TO PREVENT BUCKLING

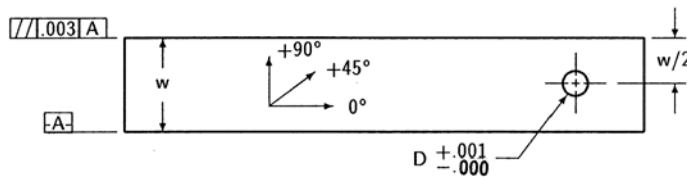
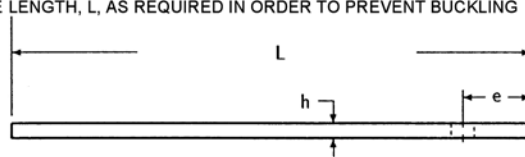

Parameter	Standard Dimension, in.
fastener or pin diameter, d	0.250 +0.000/-0.001
hole diameter, D	0.250 +0.001/-0.000
thickness range, h	0.125-0.208
length, L	5.5
width, w	1.5 ±0.03
edge distance, e	0.75 ±0.03
countersink	none

FIG. 2 Double-Shear and One-Piece Single-Shear Test Specimen Drawing (Inch-Pound)

compressive loading, although the specimen/fixture assembly may be loaded in either tension or compression.

4.2.2 Both the applied force and the associated deformation of the hole(s) are monitored. The deformation of the hole(s) is normalized by the hole diameter (a factor of two used to adjust for hole deformation occurring in the two halves) to result in an effective bearing strain. Likewise, the applied force is normalized by the projected hole area to yield an effective bearing stress. The specimen is loaded until a maximum force has clearly been reached, whereupon the test is terminated so as to prevent masking of the true failure mode by large-scale hole distortion, in order to provide a more representative failure mode assessment. Bearing stress versus bearing strain for the entire loading regime is plotted, and failure mode noted. The ultimate bearing strength of the material is determined from the maximum force carried prior to test termination.

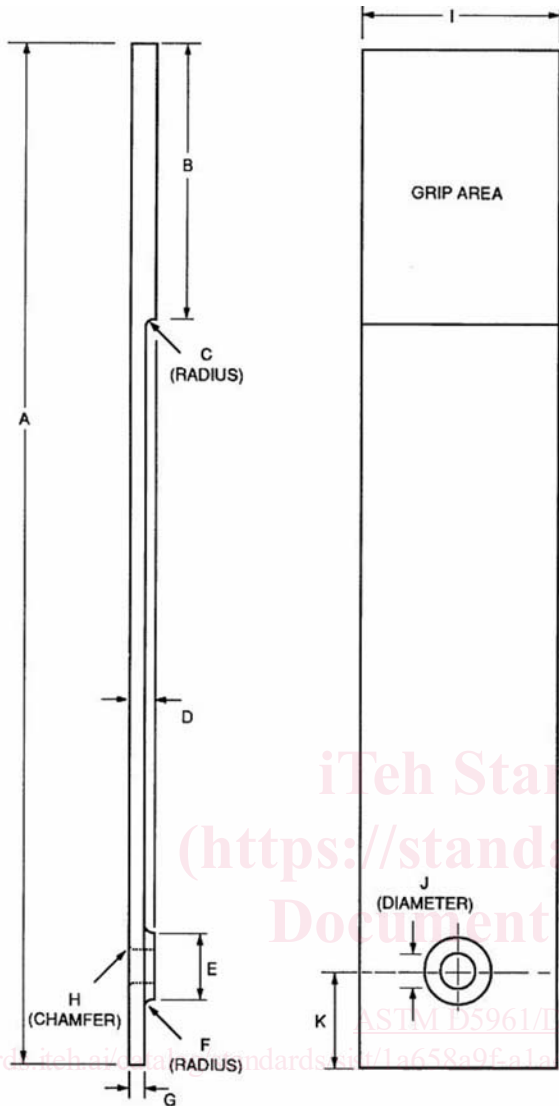

iTeh Standards
 (https://standards.itih.ai)
 Document Preview

ASTM D5961/D5961M-10
 https://standards.itih.ai/standards/17/1a658a9fa1a8-481a-9be7-41c908e83fla/astm-d5961-d5961m-10

Recommended Material: 17-4PH Stainless Steel, 1 GPa [145 ksi] yield												L	M	N	P
mm	A	B	C	D	E	F	G	H	I	J	K	0.3	0.1	0.013	0.8 micro-in
inch	200	50	2	5	13	2	3	1	36	6	20	0.03	0.01	0.003	32 micro-in
	7.75	2.00	0.06	0.20	0.50	0.06	0.12	0.04	1.50	0.25	0.75				

NOTES:

1. Tolerances unless otherwise stated are (SI: X.X±L, X.XX±M) (US: X.XX±L, X.XXX±M)
2. Surface finish is P.

FIG. 3 Fixture Loading Plate for Procedure A (2 Required)

4.2.3 The standard test configuration for this procedure does not allow any variation of the major test parameters. However, the following variations in specimen and test fixture configuration are allowed, but can be considered as being in accordance with this test method only as long as the values of all variant test parameters are prominently documented with the results:

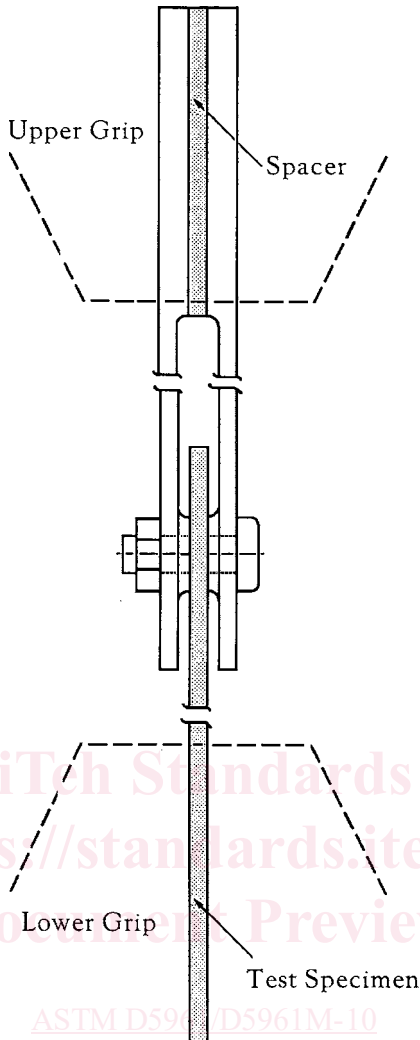

FIG. 4 Fixture Assembly for Procedure A

Parameter	Standard	Variation
Loading condition:	single-shear	none
Support fixture:	no	yes, if documented
Number of holes:	1	1 or 2
Countersunk holes:	no	yes, if documented
Grommets:	no	yes, if documented
Mating material:	same laminate	any, if documented
Fit:	tight	any, if documented
Fastener torque:	2.2-3.4 N·m [20-30 lbf·in.]	any, if documented
Laminate:	quasi-isotropic	any, if documented
Fastener diameter:	6 mm [0.250 in.]	any, if documented
Edge distance ratio:	3	any, if documented
w/D ratio:	6	any, if documented
D/h ratio:	1.2-2	any, if documented

4.3 Procedure C, Single Shear, One-Piece Specimen:

4.3.1 A flat, constant rectangular cross-section test specimen with a centerline hole located near the end of the specimen, as shown in the test specimen drawings of Figs. 1 and 2, is loaded at the hole in bearing. The bearing force is normally applied, by a fixture similar to that shown in Fig. 10, through a close-tolerance, lightly torqued fastener that is reacted in single shear, as shown in Fig. 11. The bearing force is created by loading the assembly in tension in a testing machine.

4.3.2 Both the applied force and the associated deformation of the hole are monitored. The hole deformation is normalized by the hole diameter to create an effective bearing strain. Likewise, the applied force is normalized by the projected hole area to create an effective bearing stress. The specimen is loaded until a maximum force has clearly been reached, whereupon the test is terminated so as to prevent masking of the true failure mode by large-scale hole distortion, in order to provide a more representative failure mode assessment. Bearing stress versus bearing strain for the entire loading regime is plotted, and failure mode noted. The ultimate bearing strength of the material is determined from the maximum force carried prior to test termination.

DRAWING NOTES:

1. INTERPRET DRAWING IN ACCORDANCE WITH ANSI Y14.5M-1982, SUBJECT TO THE FOLLOWING:
2. ALL DIMENSIONS IN MILLIMETRES WITH DECIMAL TOLERANCES AS FOLLOWS:

NO DECIMAL	.X	.XX
±1	±0.3	±0.1
3. ALL ANGLES HAVE TOLERANCE OF $\pm .5^\circ$.
4. PLY ORIENTATION DIRECTION TOLERANCE RELATIVE TO -A- WITHIN $\pm .5^\circ$.
5. FINISH ON MACHINED EDGES NOT TO EXCEED $\sqrt{1.6}$ SYMBOLY IN ACCORDANCE WITH ASA B46.1, WITH ROUGHNESS HEIGHT IN MICROMETRES.)
6. VALUES TO BE PROVIDED FOR THE FOLLOWING, SUBJECT TO ANY RANGES SHOWN ON THE FIELD OF DRAWING; MATERIAL, LAY-UP, PLY ORIENTATION REFERENCE RELATIVE TO -A-, OVERALL LENGTH, HOLE DIAMETER, COUNTERSINK DETAILS, COUPON THICKNESS, DOUBLER MATERIAL, DOUBLER ADHESIVE.

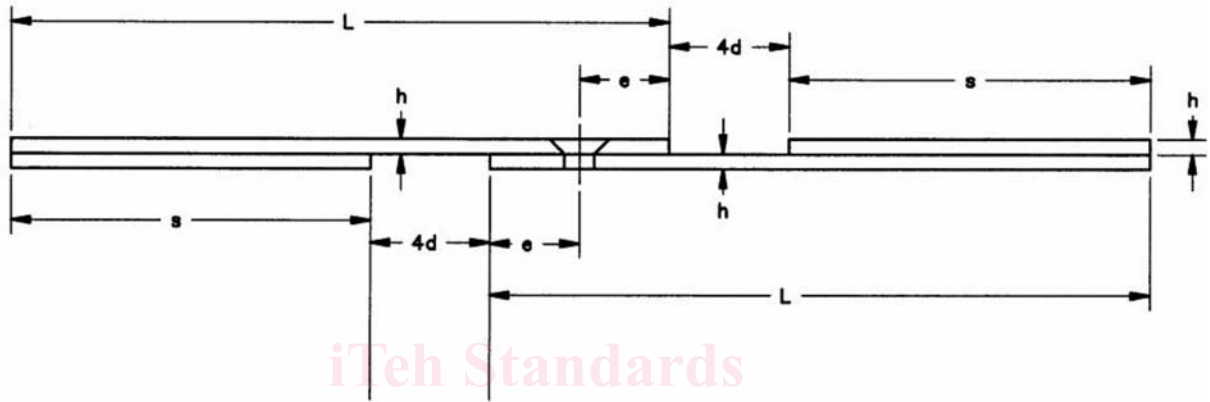

//.08 A

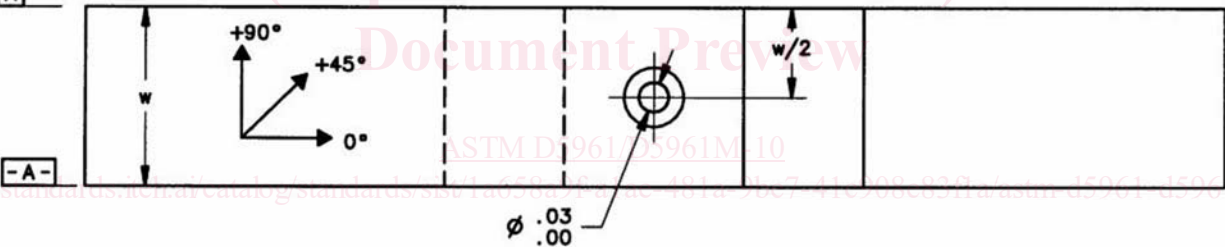

Parameters	Standard Dimensions of Specimen (mm)	
	without support fixture	with support fixture
fastener diameter, d	6+0.00/-0.03	6+0.00/-0.03
hole diameter, ϕ	6+0.03/-0.00	6+0.03/-0.00
thickness range, h	3-5	3-5
length, L	135	189
width, w	36 +/-1	36 +/-1
edge distance, e	18 +/-1	18 +/-1
countersink	none(optional)	none (optional)
doubler length, s	75	129

FIG. 5 Single-Shear, Two-Piece Single-Fastener Test Specimen Drawing (SI)

4.3.3 The standard test configuration for this procedure does not allow any variation of the major test parameters. However, the following variations in specimen and test fixture configuration are allowed, but can be considered as being in accordance with this test method only as long as the values of all variant test parameters are prominently documented with the results:

DRAWING NOTES:

1. INTERPRET DRAWING IN ACCORDANCE WITH ANSI Y14.5M-1982, SUBJECT TO THE FOLLOWING:
2. ALL DIMENSIONS IN INCHES WITH DECIMAL TOLERANCES AS FOLLOWS:

.X	.XX	.XXX
+/- .1	+/- .03	+/- .003
3. ALL ANGLES HAVE TOLERANCE OF +/- .5°.
4. PLY ORIENTATION DIRECTION TOLERANCE RELATIVE TO \square -A- WITHIN +/- .5°.
5. FINISH ON MACHINED EDGES NOT TO EXCEED $\sqrt{64}$ SYMBOLY IN ACCORDANCE WITH ASA B46.1, WITH ROUGHNESS HEIGHT IN MICROINCHES.)
6. VALUES TO BE PROVIDED FOR THE FOLLOWING, SUBJECT TO ANY RANGES SHOWN ON THE FIELD OF DRAWING; MATERIAL, LAY-UP, PLY ORIENTATION REFERENCE RELATIVE TO \square -A-, OVERALL LENGTH, HOLE DIAMETER, COUNTERSINK DETAILS, COUPON THICKNESS, DOUBLER MATERIAL, DOUBLER ADHESIVE.

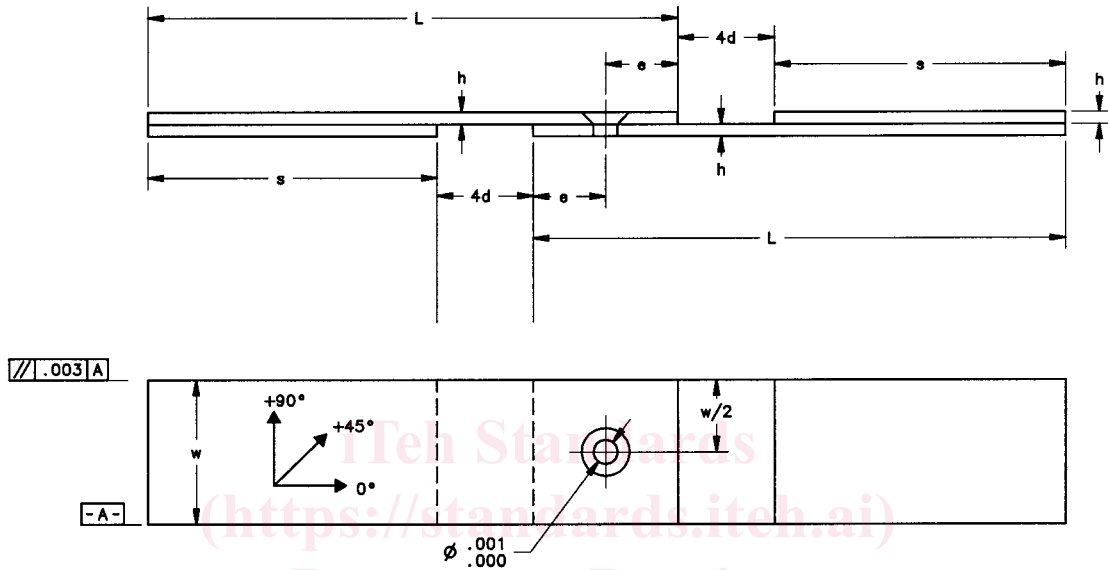

Parameters	Standard Dimensions of Specimen (inches)	
	without support fixture	with support fixture
fastener diameter, d	0.250+0.000/-0.001	0.250 +0.000/-0.001
hole diameter, ϕ	0.250+0.001/-0.000	0.250 +0.001/-0.000
thickness range, h	0.125-0.208	0.125-0.208
length, L	5.5	7.5
width, w	1.5+/-0.03	1.5+/-0.03
edge distance, e	0.75+/-0.03	0.75+/-0.03
countersink	none (optional)	none (optional)
doubler length, s	3.0	5.0

FIG. 6 Single-Shear Two-Piece Test Specimen Drawing (Inch-Pound)

Parameter	Standard	Variation
Loading condition:	single-shear	none
Mating material:	steel fixture	none
Number of holes:	1	none
Countersink:	yes	no, if documented
Fit:	tight	any, if documented
Fastener torque:	2.2-3.4 N-m [20-30 lbf-in.]	any, if documented
Laminate:	quasi-isotropic	any, if documented
Fastener diameter:	6 mm [0.250 in.]	any, if documented
Edge distance ratio:	3	any, if documented
w/D ratio:	6	any, if documented
D/h ratio:	1.2-2	any, if documented

4.4 Procedure D, Double Shear, Compression:

4.4.1 A flat, constant rectangular cross-section test specimen with a centerline hole located near the end of the specimen, as shown in the test specimen drawings of Figs. 1 and 2, is loaded at the hole in bearing. The bearing force is normally applied, by a fixture similar to that shown in Fig. 12, through a close-tolerance, lightly torqued fastener (or pin) that is reacted in double shear, as shown in Fig. 13. The bearing force is created by loading the assembly in compression in a testing machine.

4.4.2 Both the applied force and the associated deformation of the hole are monitored. The hole deformation is normalized by

- DRAWING NOTES:**
1. INTERPRET DRAWING IN ACCORDANCE WITH ANSI Y14.5M-1982, SUBJECT TO THE FOLLOWING:
 2. ALL DIMENSIONS IN MM WITH DECIMAL TOLERANCES AS FOLLOWS:

NO DECIMAL	.X	.XX X
±1	±0.3	±0.1
 3. ALL ANGLES HAVE TOLERANCE OF +/- .5°.
 4. PLY ORIENTATION DIRECTION TOLERANCE RELATIVE TO **-A-** WITHIN +/- .5°.
 5. FINISH ON MACHINED EDGES NOT TO EXCEED $1.6 \sqrt{\text{R}}$ SYMBOLGY IN ACCORDANCE WITH ASA B46.1, WITH ROUGHNESS HEIGHT IN MICROMETRES.)
 6. VALUES TO BE PROVIDED FOR THE FOLLOWING, SUBJECT TO ANY RANGES SHOWN ON THE FIELD OF DRAWING; MATERIAL, LAY-UP, PLY ORIENTATION REFERENCE RELATIVE TO **-A-**, OVERALL LENGTH, HOLE DIAMETER, COUNTERSINK DETAILS, COUPON THICKNESS, DOUBLER MATERIAL, DOUBLER ADHESIVE.

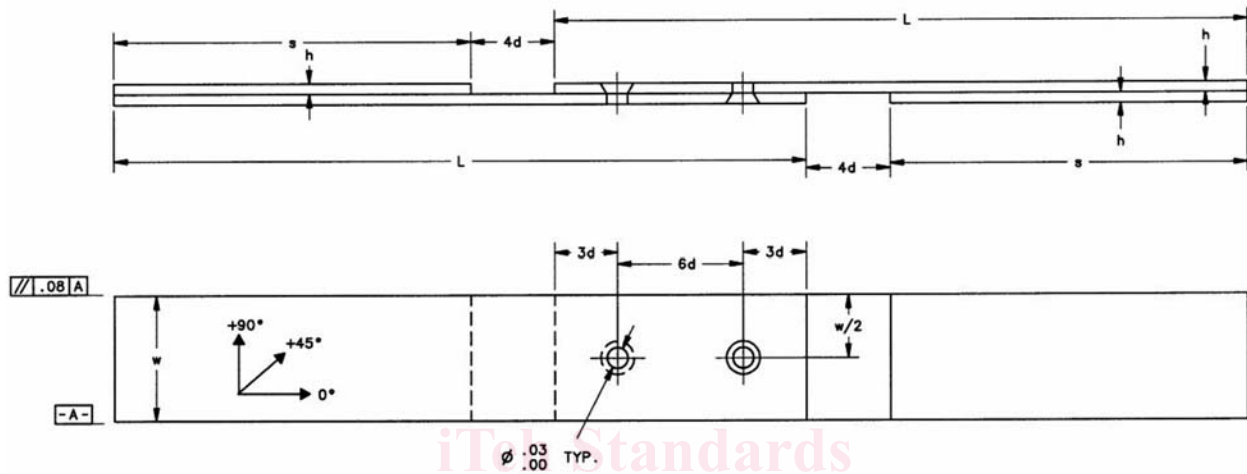

Parameters	Standard Dimensions of Specimen (mm)	
	without support fixture	with support fixture
fastener diameter, d	6 + 0.00/-0.03	6 + 0.00/-0.03
hole diameter, ϕ	6 + 0.03/-0.00	6 + 0.03/-0.00
thickness range, h	3-5	3-5
length, L	210	210
width, w	36 +/- 1	36 +/- 1
edge distance, e	18 +/- 1	18 +/- 1
countersink	none(optional)	none (optional)
doubler length, s	108	108

FIG. 7 Single-Shear, Two-Piece Double-Fastener Test Specimen Drawing (SI)

the hole diameter to create an effective bearing strain. Likewise, the applied force is normalized by the projected hole area to create an effective bearing stress. The specimen is loaded until a maximum force has clearly been reached, whereupon the test is terminated so as to prevent masking of the true failure mode by large-scale hole distortion, in order to provide a more representative failure mode assessment. Bearing stress versus bearing strain for the entire loading regime is plotted, and failure mode noted. The ultimate bearing strength of the material is determined from the maximum force carried prior to test termination.

4.4.3 The standard test configuration for this procedure does not allow any variation of the major test parameters, other than overall specimen length (in order to preclude specimen buckling). However, the following variations in specimen and test fixture configuration are allowed, but can be considered as being in accordance with this test method only as long as the values of all variant test parameters are prominently documented with the results:

Parameter	Standard	Variation
Loading condition:	double-shear	none
Mating material:	steel fixture	none
Number of holes:	1	none
Countersink:	none	none
Fit:	tight	any, if documented
Fastener torque:	2.2-3.4 N-m [20-30 lbf-in.]	any, if documented
Laminate:	quasi-isotropic	any, if documented
Fastener diameter:	6 mm [0.250 in.]	any, if documented
Edge distance ratio:	3	any, if documented
w/D ratio:	6	any, if documented
D/h ratio:	1.2-2	any, if documented

5. Significance and Use

5.1 This test method is designed to produce bearing response data for material specifications, research and development, quality

