



Designation: D6898 – 03(Reapproved 2010)

Standard Test Method for Evaluating Diesel Fuel Lubricity by an Injection Pump Rig¹

This standard is issued under the fixed designation D6898; the number immediately following the designation indicates the year of original adoption or, in the case of revision, the year of last revision. A number in parentheses indicates the year of last reapproval. A superscript epsilon (ϵ) indicates an editorial change since the last revision or reapproval.

INTRODUCTION

All diesel fuel injection equipment relies, to some extent, on diesel fuel as a lubricant. Shortened life of diesel fuel injection pumps and injectors from wear caused by excessive friction has sometimes been ascribed to lack of lubricity in the fuel. This test assesses the lubricity of a fuel by operation of the fuel in a typical fuel injection system comprised of injection pump, high pressure pipes, and injectors on a pump test rig bench. The test models an actual commercial application of such equipment. The pump performance is evaluated on a test bench meeting SAE J1668 requirements.

1. Scope

1.1 This test method covers evaluating the lubricity of diesel fuels using a pump rig test and Stanadyne Model DB4427-4782 pumps.

NOTE 1—Other pumps may be used if a correlation between pump performance factors and fuel lubricity has been developed.

1.2 This test method is applicable to any fuel used in diesel engines, including those which may contain a lubricity enhancing additive.

1.3 The values stated in SI units are to be regarded as standard. No other units of measurement are included in this standard.

1.4 *This standard does not purport to address all of the safety concerns, if any, associated with its use. It is the responsibility of the user of this standard to establish appropriate safety and health practices and determine the applicability of regulatory limitations prior to use.* Specific warning statements are given in Section 7.

2. Referenced Documents

2.1 ASTM Standards:²

[D329 Specification for Acetone](#)

[D362 Specification for Industrial Grade Toluene \(Withdrawn 1989\)³](#)

[D4057 Practice for Manual Sampling of Petroleum and Petroleum Products](#)

[D4177 Practice for Automatic Sampling of Petroleum and Petroleum Products](#)

[D4306 Practice for Aviation Fuel Sample Containers for Tests Affected by Trace Contamination](#)

[D6078 Test Method for Evaluating Lubricity of Diesel Fuels by the Scuffing Load Ball-on-Cylinder Lubricity Evaluator \(SLBOCLE\)](#)

[D6079 Test Method for Evaluating Lubricity of Diesel Fuels by the High-Frequency Reciprocating Rig \(HFRR\)](#)

2.2 SAE Standards:⁴

[SAE J967 Calibration Fluid for Diesel Injection Equipment](#)

[SAE J968/1 Diesel Injection Pump Testing—Part 1: Calibrating Nozzles and Holder Assemblies](#)

[SAE J1418 Fuel Injection Pumps—High Pressure Pipes \(Tubing\) for Testing](#)

[SAE J1668 Diesel Engines—Fuel Injection Pump Testing](#)

3. Terminology

3.1 Definitions of Terms Specific to This Standard:

3.1.1 *boundary lubrication, n*—a condition in which the friction and wear between two surfaces in relative motion are determined by the properties of the surfaces and the properties of the contacting fluid, other than bulk viscosity.

3.1.1.1 *Discussion*—Metal to metal contact occurs and the chemistry of the system is involved. Physically adsorbed or

¹ This test method is under the jurisdiction of ASTM Committee D02 on Petroleum Products, Liquid Fuels, and Lubricants and is the direct responsibility of Subcommittee D02.E0 on Burner, Diesel, Non-Aviation Gas Turbine, and Marine Fuels.

Current edition approved Oct. 1, 2010. Published November 2010. Originally approved in 2003. Last previous edition approved in 2003 as D6898-03. DOI: 10.1520/D6898-03R10.

² For referenced ASTM standards, visit the ASTM website, www.astm.org, or contact ASTM Customer Service at service@astm.org. For *Annual Book of ASTM Standards* volume information, refer to the standard's Document Summary page on the ASTM website.

³ The last approved version of this historical standard is referenced on www.astm.org.

⁴ Available from Society of Automotive Engineers (SAE), 400 Commonwealth Dr., Warrendale, PA 15096-0001.

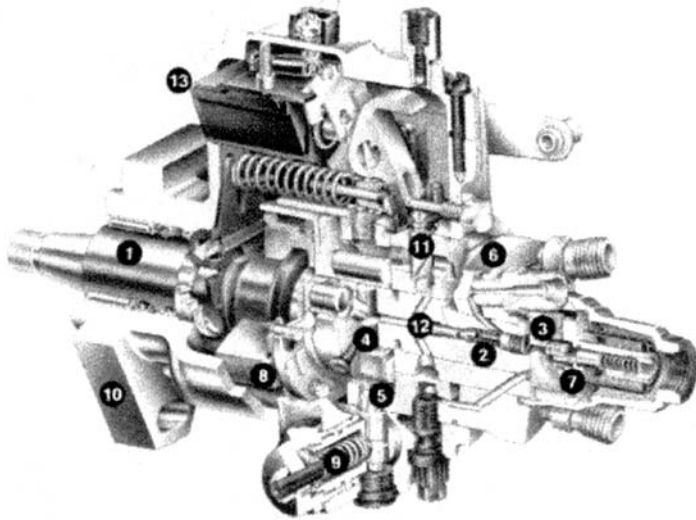

1. Drive Shaft
2. Distributor Rotor
3. TP Blades
4. Pumping Plungers (4)
5. Internal Cam Ring
6. Hydraulic Head
7. Pressure Regulator Assembly
8. Governor
9. Automatic Advance
10. Housing
11. Metering Valve
12. Delivery Valve
13. Electric Shutoff Solenoid

Trademark of STANADYNE Diesel Systems

FIG. 1 Schematic of Stanadyne Model DB4427-4782 Pump

chemically reacted soft films (usually very thin) support contact loads. Consequently, some wear is inevitable.

3.1.2 *lubricity, n*—a qualitative term describing the ability of a fluid to affect friction between, and wear to, surfaces in relative motion under load.

3.1.2.1 *Discussion*—In this test method, the lubricity of a fluid is evaluated by comparing critical pump component dimensions, fuel flow rate and transfer pump pressures before and after testing under defined and controlled conditions. A computed value known as pump lubricity value (PLV) results.

3.1.3 *roller-to-roller (R-R), n*—a linear measurement of opposing pumping plungers in an injection pump when pressurized to force the plungers outward against the adjustable stop mechanism.

3.1.4 *transfer pump (TP), n*—a vane type low pressure supply pump internal to an injection pump.

4. Summary of Test Method

4.1 Prior to the start of the 500 h test, the roller-to-roller (R-R) dimension and transfer pump (TP) blade thickness are measured on two new or rebuilt pumps. The fuel flow ($\text{mm}^3/\text{stroke}$) and TP pressure (kPa) of each pump are measured at 100 rpm increments from 1000 to 2200 rpm.

4.2 The pumps are mounted on the test bench and a thorough flushing process is performed. The test fuel(s) are stored in epoxy-lined containers (55 U.S. gal drums are suitable) which are plumbed to the test bench.

4.3 The pumps are operated at 1100 rpm for 500 h at the specified test conditions.

4.4 The pumps are removed from the test bench and the pre-test measurements are repeated.

4.5 The pre- and post- test data are used to compute the pump lubricity value (PLV).

5. Significance and Use

5.1 Diesel fuel injection equipment has some reliance on lubricating properties of the diesel fuel. Shortened life of engine components, such as diesel fuel injection pumps and injectors, has sometimes been ascribed to lack of lubricity in a diesel fuel.

5.2 Pump Lubricity Value (PLV) test results generally rank fuel effects on diesel injection system pump component distress due to wear in the same order as Bosch, Lucas, Stanadyne, and Cummins in-house rig tests.⁵ In these fuel/hardware tests, boundary lubrication is believed to be a factor in the operation of the component.

5.3 The PLV is sensitive to contamination of the fluids and test materials and the temperature of the test. Lubricity evaluations are also sensitive to trace contaminants acquired during test fuel sampling and storage.

5.4 Test Methods D6078 and D6079 are two methods for evaluating diesel fuel lubricity. No absolute correlation has been developed between these two test methods, or between either of these methods and the PLV.

5.5 The PLV may be used to evaluate the relative effectiveness of a fluid for preventing wear under the prescribed test conditions.

5.6 This test method is designed to evaluate boundary lubrication properties. While viscosity effects on lubricity are not totally eliminated, they are minimized.

5.7 This test can indicate whether or not an additive will improve the lubricity of a poor lubricity fuel.

⁵ Nikanjam, M., Crosby, T., Henderson, P., Gray, C., Meyer, K., and Davenport, N., "ISO Diesel Fuel Lubricity Round Robin Program," SAE Paper 952372, Oct. 16-19, 1995.

TEST STAND: ISO 4008:

- CALIBRATING HIGH PRESSURE PIPES...SAE J1418/ISO 4093: .063" (1.6 mm) I.D. x 25" (635 mm) LONG.
- CALIBRATING INJECTORS... SAE J968/ISO 7440: 0.5 mm ORIFICE PLATE NOP: 3000 PSI (207 BAR).
- CALIBRATION FLUID...SAE J967/ISO 4113 (REF. S.B. 201):
 - TEMPERATURE AT INLET 110°–115°F (43°–46°C)
 - SUPPLY PRESSURE (S.B. 334): 2.0 ± 0.5 PSI. (14 ± 3 kPa) AT PUMP INLET.
- CAM MOVEMENT READ-OUT DEVICE: #23745.

PUMP INSTALLATION: IT-013

ROTATION-C*	LEVER ANGLES (REF.)
NAME PLATE-L-SIDE**	THOT MIN. (L/B) N/A
#1 CYL.-5-O'CLOCK**	THOT MAX. (L/C) N/A
THROTTLE-R-SIDE**	S.O. (L/E) N/A
TIMING MARK 131.5°	S.O. (L/F) N/A
E.S.O. (12V E.T.R.)	

*VIEWED FROM DRIVE END **VIEWED FROM TRANSFER PUMP END

PUMP OPERATING SPEED...HALF...ENGINE SPEED
AIR TIMED TO HOUSING FLANGE (SEE SPECIAL NOTES)
MECHANICALLY TIMED TO CAM (REF. S.B. 177)

PUMP CALIBRATION CHECKS: AS RECEIVED FOR SERVICE
(REF. SL-222)

- 1000 RPM WOT:** OPERATE PUMP FOR 10 MINUTES TO BRING TO OPERATING TEMPERATURE AND CLEAR AIR FROM SYSTEM.
- 2420 RPM (WOT):** RESET HIGH IDLE SCREW IF NECESSARY TO OBTAIN 10–12 mm³/STROKE.
- CHECK POINTS:** (SEQUENCE MUST BE FOLLOWED AS LISTED)

RPM	THROTTLE POSITION	mm ³ /STROKE	ADVANCE
a. 150	WOT	35 MIN.	---
b. 400	WOT*	4 MAX.	---
c. 850	L.I.**	10–12	---
d. 1200	WOT	---	2.0°–4.0°
e. 1500	WOT	74–80	5.0°–7.0°
f. 2200	WOT	67.5–71.5	7.5°–8.5°
g. 2200	WOT*	4 MAX.	---
h. 2420	WOT	10–12	---
i. 2470	WOT	5 MAX.	---

* E.S.O. DE-ENERGIZED
** RESET USING LOW IDLE SCREW, IF NECESSARY

PUMP SETTINGS: FOLLOWING PUMP SERVICE

- ROLLER-TO-ROLLER DIMENSION... 1.958" ± .001" (49.72 mm ± 0.04 mm)
MAXIMUM ECCENTRICITY: .004" (0.10 mm) T.I.R.
- GOVERNOR LINKAGE GAP: .125"–.165" (3.2–4.2 mm) (USE KIT #23093 S.B. 95)
- 1000 RPM (WOT):** OPERATE PUMP FOR 10 MINUTES TO BRING TO OPERATING TEMPERATURE AND CLEAR AIR FROM SYSTEM.
- 400 RPM (WOT):**
 - CHECK SHUT-OFF: 4 mm³/STROKE, MAX.
 - CHECK FOR MINIMUM TRANSFER PUMP LIFT OF 18" HG. (60 kPa)
- 2200 RPM (WOT):**
 - SET TRANSFER PUMP PRESSURE 84-86 PSI, (580–593 kPa)(SUPPLY SET PER TEST STAND NOTE 3B)
 - ADJUST RETURN OIL TO 200–500 CC/MIN. RECHECK TRANSFER PUMP PRESSURE.
 - CHECK HOUSING PRESSURE FOR 4–8.5 PSI, (28–59 kPa).
- 1500 RPM (WOT):** SET ADVANCE TRIMMER SCREW FOR 6.0°.
- 2200 RPM (WOT):** SET ROLLER-TO-ROLLER FUEL DELIVERY: 69–70 mm³/STROKE.
- 2420 RPM (WOT):** ADJUST HIGH IDLE SCREW TO OBTAIN 10–12 mm³/STROKE.
- 850 RPM (L.I.):**
 - SET THROTTLE LEVER STOP SCREW FOR 10–12 mm³/STROKE, THEN BACK OUT 2 FULL TURNS AND LOCK.
 - SET LOW IDLE SCREW (COVER) FOR 10–12 mm³/STROKE.
- CHECK POINTS:**

	RPM PRESSURE	THROTTLE POSITION	mm ³ /STROKE	ADVANCE	T.P.
a.	150	WOT	36 MIN.	---	10 MIN.**
b.	400	WOT*	4 MAX.	---	---
c.	850	L.I.	10–12	---	---
d.	1200	WOT	---	2.0°–4.0°	---
e.	1500	WOT	75–79	5.5°–6.5°	---
f.	2200	WOT	69–70	7.5°–8.5°	84–86***
g.	2200	WOT*	4 MAX.	---	---
h.	2420	WOT	10–12	---	---
i.	2470	WOT	5 MAX.	---	---

* E.S.O. DE-ENERGIZED ** (69 kPa) *** (580–593 kPa)

- SPECIAL NOTES:**
 - TORQUE ALL FASTENERS PER S.B. 106.
 - ELECTRIC SHUT-OFF TO BE CHECKED PER S.B. 108.
 - ASSEMBLE THROTTLE LEVER SPACER AND ARM IN B4-L POSITION PER S.B. 164.
 - ASSEMBLE DRIVE COMPONENTS PER S.B. 438.
 - SEAL FASTENERS PER S.B. 134.
- FOR SERVICE ONLY:**

AIR TIME PUMP USING HARTRIDGE BASIC AIR TIMING TOOL 7244-27 WITH INSERT 7244-30 AND PILOT RING 7244-26E. CONNECT AIR SUPPLY WITH 60–100 PSI (4.1–6.9 BAR) TO #1 CYLINDER OUTLET. SET TOOL TO 105° AND INSTALL TO DRIVE SHAFT. SLOWLY ROTATE TOOL CLOCKWISE UNTIL ROLLERS STRIKE CAM AND TOOL STOPS, SCRIBE LINE ON HOUSING FLANGE. REPEAT PROCEDURE TO ENSURE ACCURACY. IF INTERFERENCE BETWEEN STRAIGHT EDGE AND HOUSING FLANGE OCCURS, PLACE WASHER (i.e. 13521) BETWEEN STRAIGHT EDGE AND TOOL.

Trademark of STANADYNE Diesel Systems
All speeds are in engine rpm unless otherwise noted.
Use latest revision for all Referenced Documents.

FIG. 2 Injection Pump Specification (Service/Assembly) Model No.: DB4427-4782

6. Apparatus

6.1 *Test Pumps*—The test pumps are Stanadyne 4-cylinder model DB4427-4782 pump⁶ (see Fig. 1). Providing they meet the Stanadyne DB4427-4782 specifications (see Fig. 2), the pumps can be new or rebuilt. The test pump must always use new head and rotor, and TP assemblies. While a single pump can be tested, the preferred method is to test two pumps simultaneously with the same test fuel.

⁶ The sole source of supply of the pumps known to the committee at this time is Stanadyne Automotive Corp., 92 Deerfield Rd., Windsor, CT 06095-2409, or a registered service dealer. If you are aware of alternative suppliers, please provide this information to ASTM International Headquarters. Your comments will receive careful consideration at a meeting of the responsible technical committee¹, which you may attend.

6.2 *Performance Test Bench*—An SAE J1668 test bench is used for performance testing of each test pump.

6.3 *Calibrating Injector*—A calibrating nozzle and holder assembly with a single hole orifice plate, in accordance with SAE J968/1, is used for performance testing of each test pump.

6.4 *Pump Test Rig*—The pump test rig consists of an electric motor driven test bench capable of driving two test pumps simultaneously at a specified speed (see Fig. 3). The test rig is equipped with stainless steel low pressure piping with fuel inlet pipes from a drum of test fuel. Boost pumps in the inlet lines pump fuel through fuel filters to the inlet of the test pumps. Fuel is discharged from the test pumps through specified inside diameter and length high pressure pipe, to the specified injectors. The injectors are housed in accumulators to collect

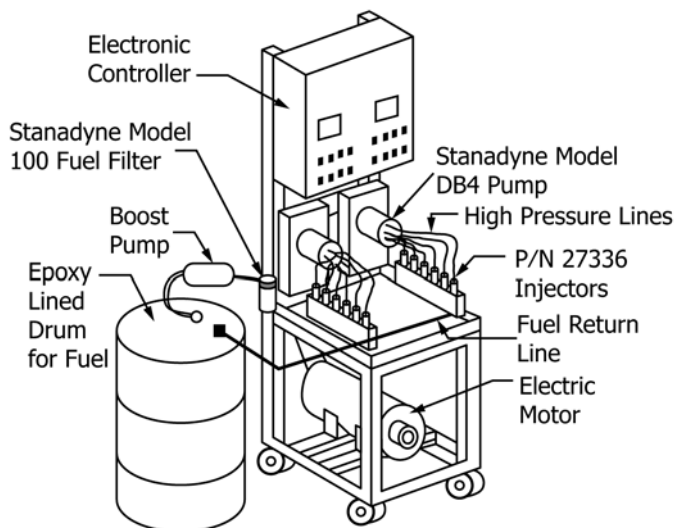

NOTE 1—The system shown in this figure is a six-cylinder (six injectors) pump, while the test pump (see 6.1) is a four-cylinder application.

FIG. 3 Test Rig Portable Bench

the discharged fuel and return it to the drum. Thus the fuel system is closed and the fuel continuously recirculates. The test rig is operated in a room with an ambient temperature of $24 \pm 3^\circ\text{C}$.

6.5 *Electric Motor*, an adjustable speed motor capable of producing speeds to 1500 rpm and a torque of 122 N-m.

6.6 *Low Pressure Piping*, 9.5 mm inside diameter stainless steel tubing of whatever length is needed for the application.

6.7 *Boost Pumps*, pumps which operate at 14 to 34 kPa and pump 76 to 114 L/h.

6.8 *Fuel Filters*, Stanadyne model 100⁷ or John Deere RF 624118.

6.9 *Filter Head/Fuel Handler*, Stanadyne 33260⁷ for attachment of fuel filters.

6.10 *High Pressure Pipes*—HP pipes in accordance with SAE J1418 are 1.6 ± 0.025 mm inside diameter \times 640 ± 5 mm long with a nominal outside diameter of 6 mm and a minimum central line bend radius of 16 mm for both the performance testing and the test rig testing.

NOTE 2—SAE J1418 specifies the length of this tubing as 600 ± 5 mm but 640 mm is required in these applications.

6.11 *Test Rig Injectors*—The test rig injectors are Stanadyne p/n 27336⁷ (see Fig. 4). These injectors are known as *engine injectors* as compared to *calibrating injectors*.

6.12 *Accumulator*, a stainless steel box, into which the injectors are screwed, that has a line to return the injected fuel back to the drum (see Fig. 5).

6.13 *Micrometer*, 25.4 to 50.8 mm with a resolution of 0.001 mm and an accuracy of 0.003 mm to measure the R-R dimension.

6.14 *Point Micrometer*, 0 to 25.4 mm with a resolution of 0.001 mm and an accuracy of 0.003 mm to measure the thickness of the TP blades.

6.15 *R-R Setting Fixture*, a special tool available from Stanadyne.⁷

6.16 *Electronic Control Unit*, any commercially available unit capable of operating the test rig.

6.17 *Tachometers*, used to measure the rpm of the test pumps.

6.18 *Thermocouples*, used to measure air temperature, and fuel temperatures in the drum, after the boost pump, after the DB4427-4782 pumps, and in the fuel return lines.

6.19 *Pressure Transducers*, used to measure the pressure after the boost pump and after the DB4427-4782 pumps.

6.20 *Flow Meters*, used to measure the fuel flow through the DB4427-4782 pumps.

6.21 *Level Sensor*, used to monitor the level of fuel in the drum.

6.22 *Hydrocarbon Gas Detector*, used to monitor for potentially explosive vapors in the room.

6.23 *Flushing Adapters*, necessary fittings and adapters to bypass the fuel filter, connect the fuel pump inlet directly to the HP pipes, and connect the HP pipes to the accumulator. These adapters are used to flush the test rig between fuel tests.

7. Reagents and Materials

7.1 *Acetone*, conforming to Specification D329. (**Warning**—Extremely flammable. Vapors may cause flash fire.)

7.2 *Calibration Fluid*, a fluid formulated from refined and deodorized fuel stocks, meeting SAE J967 specifications, used for pump performance testing.

7.3 *Compressed Air*, containing less than 0.1 ppmv hydrocarbons and 50 ppmv water. (**Warning**—Compressed gas under high pressure. Use with extreme caution in the presence of combustible material.)

7.4 *Flushing Fluid*, 75/25 mixture of toluene and acetone used to flush the pump test rig between fuel tests.

7.5 *Toluene*, conforming to Specification D362. (**Warning**—Flammable. Harmful if inhaled.)

8. Sampling and Sample Containers

8.1 Unless otherwise specified, take samples by the procedure described in Practice D4057 or Practice D4177.

8.2 Because of the sensitivity of lubricity measurements to trace materials, sample containers shall be only fully epoxy-lined metal drums, cleaned and rinsed thoroughly at least three times with the product to be sampled before use, as specified in Practice D4306.

8.3 New sample containers are preferred, but if not available, Practice D4306 gives guidance on suitable cleaning procedures.

⁷ Available from Stanadyne Automotive Corp., 92 Deerfield Rd., Windsor, CT 06095-2409, or a registered service dealer.