Industrial trucks — Vocabulary —
Part 1:
Types of industrial trucks

Chariots de manutention —
Vocabulaire —
Partie 1:
Types de chariots de manutention

<https://standards.iteh.ai/catalog/standards/sist/de4fe714-b34d-49c8-b31a-f231523cc348/iso-5053-1-2020>



iTeh STANDARD PREVIEW
(standards.iteh.ai)

ISO 5053-1:2020

<https://standards.iteh.ai/catalog/standards/sist/de4fe714-b34d-49c8-b31a-f231523cc348/iso-5053-1-2020>



COPYRIGHT PROTECTED DOCUMENT

© ISO 2020

All rights reserved. Unless otherwise specified, or required in the context of its implementation, no part of this publication may be reproduced or utilized otherwise in any form or by any means, electronic or mechanical, including photocopying, or posting on the internet or an intranet, without prior written permission. Permission can be requested from either ISO at the address below or ISO's member body in the country of the requester.

ISO copyright office
CP 401 • Ch. de Blandonnet 8
CH-1214 Vernier, Geneva
Phone: +41 22 749 01 11
Fax: +41 22 749 09 47
Email: copyright@iso.org
Website: www.iso.org

Published in Switzerland

Contents

	Page
Foreword	iv
1 Scope	1
2 Normative references	1
3 Terms and definitions	1
Annex A (informative) List of equivalent terms in German, Chinese and Italian	25
Annex B (informative) Classification	35
Bibliography	71

iTeh STANDARD PREVIEW (standards.iteh.ai)

ISO 5053-1:2020

<https://standards.iteh.ai/catalog/standards/sist/de4fe714-b34d-49c8-b31a-f231523cc348/iso-5053-1-2020>

Foreword

ISO (the International Organization for Standardization) is a worldwide federation of national standards bodies (ISO member bodies). The work of preparing International Standards is normally carried out through ISO technical committees. Each member body interested in a subject for which a technical committee has been established has the right to be represented on that committee. International organizations, governmental and non-governmental, in liaison with ISO, also take part in the work. ISO collaborates closely with the International Electrotechnical Commission (IEC) on all matters of electrotechnical standardization.

The procedures used to develop this document and those intended for its further maintenance are described in the ISO/IEC Directives, Part 1. In particular, the different approval criteria needed for the different types of ISO documents should be noted. This document was drafted in accordance with the editorial rules of the ISO/IEC Directives, Part 2 (see www.iso.org/directives).

Attention is drawn to the possibility that some of the elements of this document may be the subject of patent rights. ISO shall not be held responsible for identifying any or all such patent rights. Details of any patent rights identified during the development of the document will be in the Introduction and/or on the ISO list of patent declarations received (see www.iso.org/patents).

Any trade name used in this document is information given for the convenience of users and does not constitute an endorsement.

For an explanation of the voluntary nature of standards, the meaning of ISO specific terms and expressions related to conformity assessment, as well as information about ISO's adherence to the World Trade Organization (WTO) principles in the Technical Barriers to Trade (TBT), see www.iso.org/iso/foreword.html.

This document was prepared by Technical Committee ISO/TC 110, *Industrial trucks*, Subcommittee SC 1, *General terminology*.

This third edition cancels and replaces the second edition (ISO 5053-1:2015), which has been editorially revised.

The main changes compared to the previous edition are as follows:

- added additional names for some truck types;
- new layout.

A list of all parts in the ISO 5053 series can be found on the ISO website.

Any feedback or questions on this document should be directed to the user's national standards body. A complete listing of these bodies can be found at www.iso.org/members.html.

NOTE In addition to terms used in English and French, two of the three official ISO languages, this International Standard gives the equivalent terms in German, Chinese and Italian in [Annex A](#). These are published under the responsibility of the member bodies for Germany (DIN), China (SAC) and Italy (UNI). However, only the terms and definitions given in the official languages can be considered as ISO terms and definitions.

Industrial trucks — Vocabulary —

Part 1: Types of industrial trucks

1 Scope

This document establishes the vocabulary of industrial trucks.

For the purposes of this document, industrial trucks are wheeled vehicles having at least three wheels with a powered or non-powered driving mechanism — except those running on rails — which are designed either to carry, tow, push, lift, stack or tier in racks any kind of load, and which are controlled either by an operator or by driverless automation.

2 Normative references

There are no normative references in this document.

3 Terms and definitions

ISO and IEC maintain terminological databases for use in standardization at the following addresses:

— ISO Online browsing platform: available at <https://www.iso.org/obp>

— IEC Electropedia: available at <http://www.electropedia.org/>

NOTE Due to the variance of the individual truck types and the ongoing development of new combinations, it is not possible to illustrate all the different variations of industrial truck types. Therefore, this document defines, shows and/or describes the typical variances.

3.1

towing tractor

truck travelling on the ground, fitted with coupling means and specially designed to tow vehicles travelling on the ground

Note 1 to entry: See [Figure 1](#).

Note 2 to entry: For equivalent terms in German, Chinese and Italian, see [A.1](#).

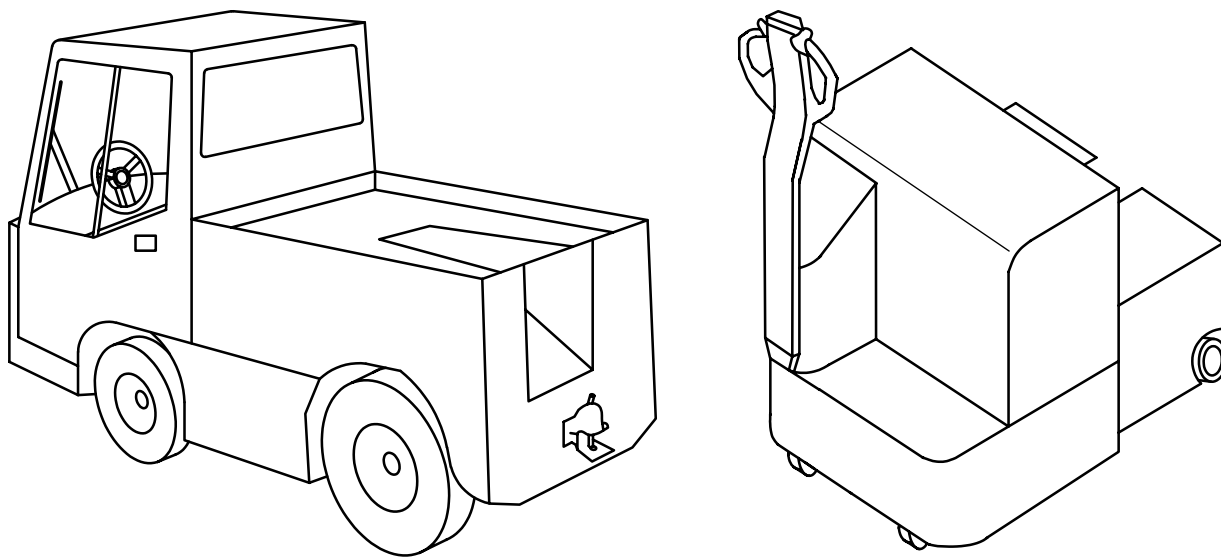

Figure 1 — Towing tractor

**3.2
pushing tractor**

tractor fitted at the front-end with a buffer plate and which can push vehicles travelling on the ground or on railway tracks

Note 1 to entry: See [Figure 2](#).

Note 2 to entry: For equivalent terms in German, Chinese and Italian, see [A.2](#).

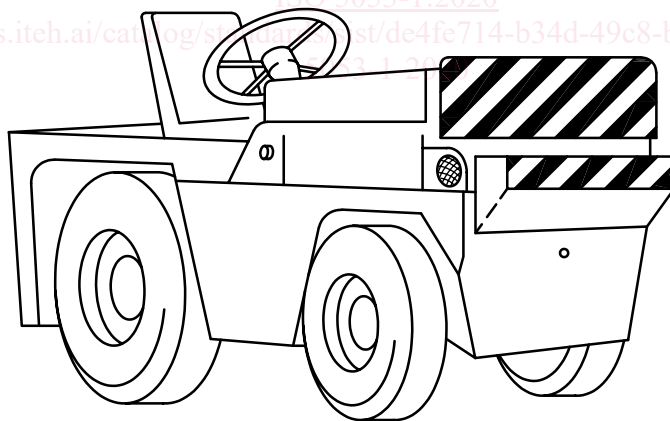

Figure 2 — Pushing tractor

**3.3
counterbalance lift truck**

stacking lift truck fitted with fork arms (or with the fork arms replaced by another device) on which the load, either palletized or not, is put in a cantilever position in relation to the front wheels and balanced by the mass of the truck

Note 1 to entry: See [Figure 3](#).

Note 2 to entry: For equivalent terms in German, Chinese and Italian, see [A.3](#).

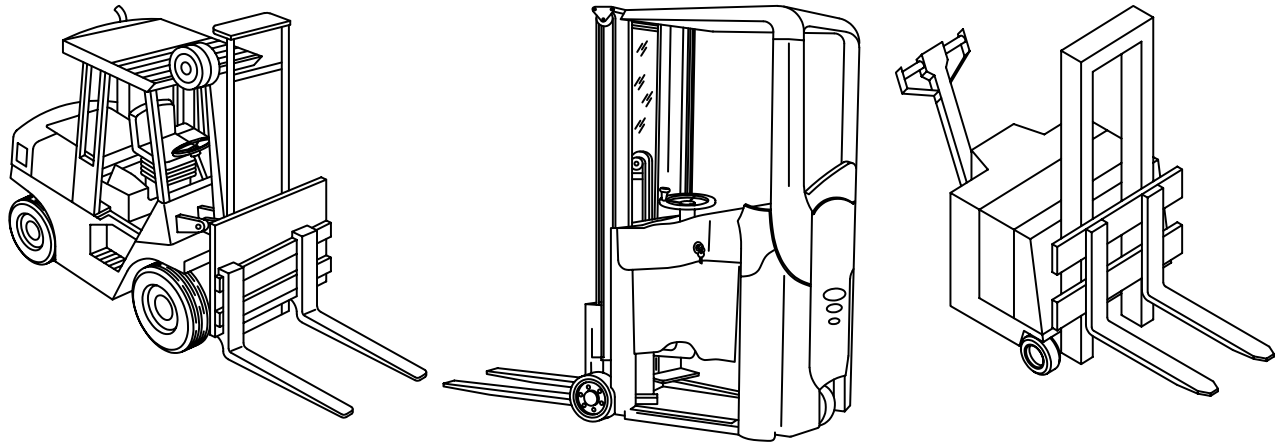

Figure 3 — Counterbalance lift truck

3.4

reach truck [with retractable mast] [with fork arm carriage]

stacking lift truck with outriggers where the load can be repositioned by moving the [retractable mast] [fork arm carriage]

Note 1 to entry: See [Figure 4](#).

Note 2 to entry: For equivalent terms in German, Chinese and Italian, see [A.4](#).

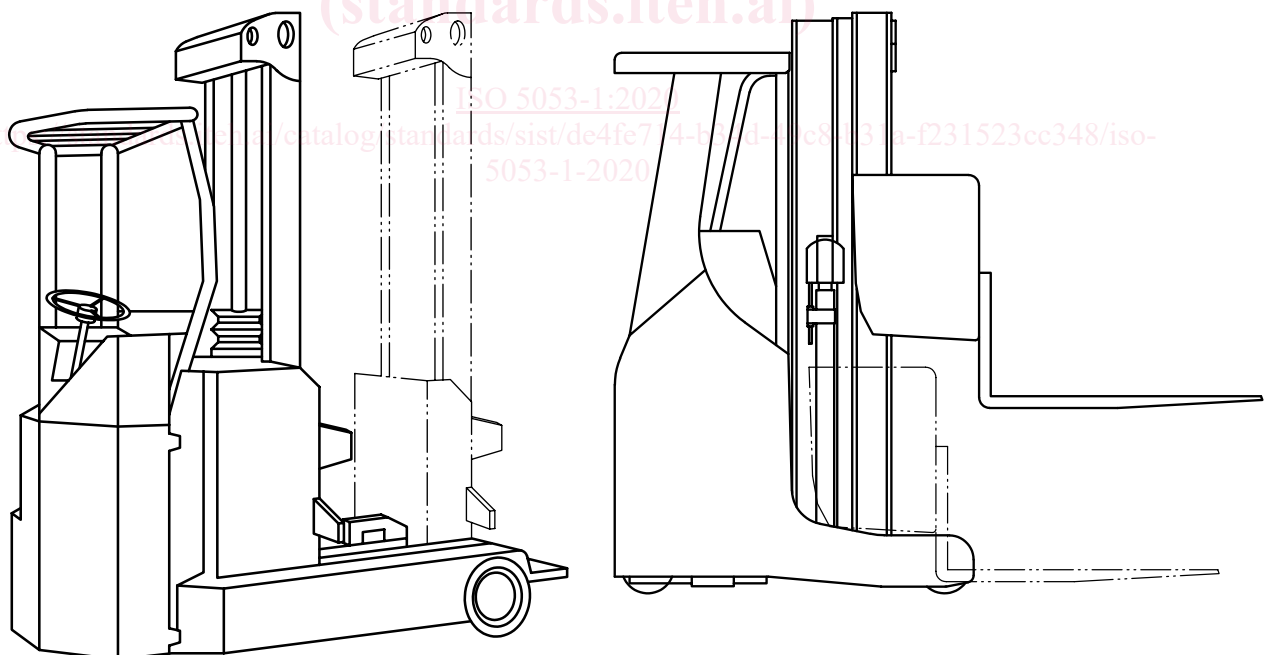

Figure 4 — Reach truck

3.5

platform truck

stacking lift truck with a load platform extending over the frame structure

Note 1 to entry: See [Figure 5](#).

Note 2 to entry: For equivalent terms in German, Chinese and Italian, see [A.5](#).

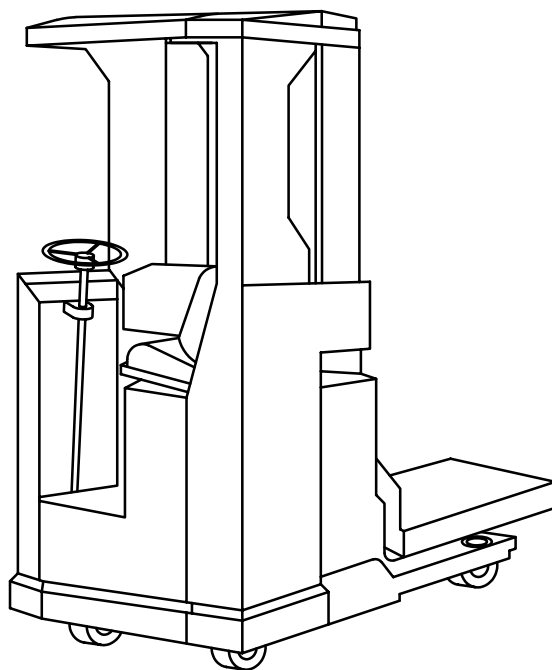

Figure 5 — Platform truck

3.6
side-loading truck

<one side only> lift truck with mast structure or fork arm carriage which can be extended and retracted between the axles and perpendicular to the longitudinal axis of the truck, allowing it to pick up and raise a load in a counterbalanced position in relation to one side of the truck and stack or unstack alongside the truck

Note 1 to entry: See [Figure 6](#).

Note 2 to entry: For equivalent terms in German, Chinese and Italian, see [A.6](#).

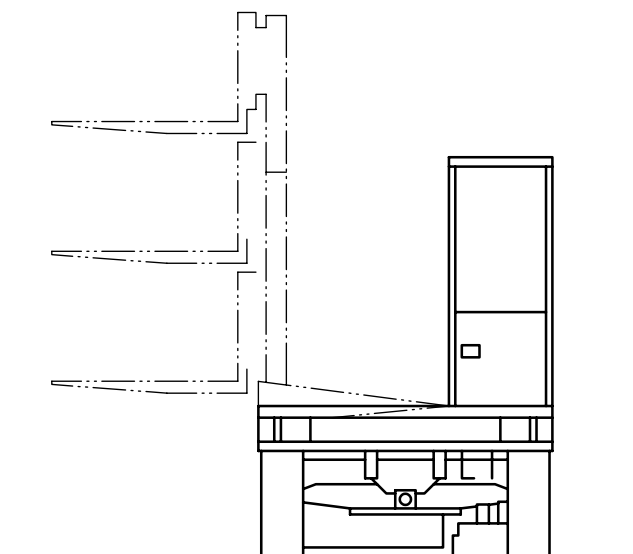

Figure 6 — Side-loading truck

3.7**rough-terrain truck**

wheeled counterbalanced truck, intended primarily for operation on unimproved natural terrain and on the disturbed terrain of, for example, construction sites

Note 1 to entry: See [Figure 7](#).

Note 2 to entry: For equivalent terms in German, Chinese and Italian, see [A.7](#).

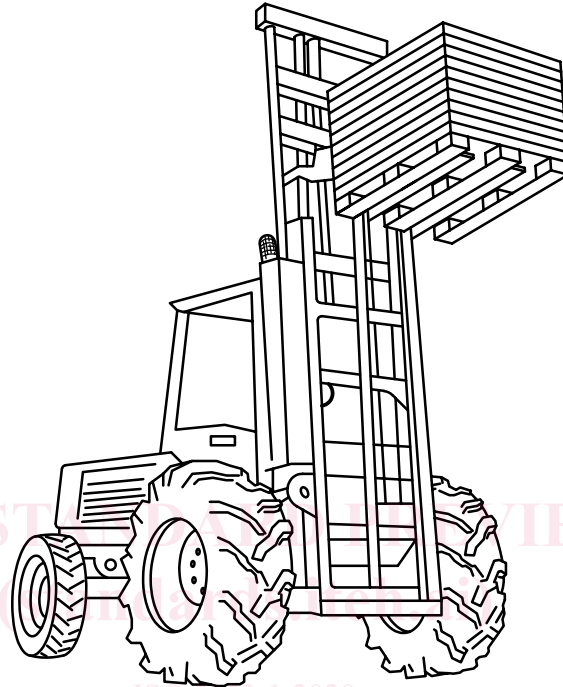

Figure 7 — Rough-terrain truck

3.8**lateral-stacking truck**

<both sides> high-lift stacking truck capable of stacking and retrieving loads on both sides of the direction of travel

Note 1 to entry: See [Figure 8](#).

Note 2 to entry: For equivalent terms in German, Chinese and Italian, see [A.8](#).

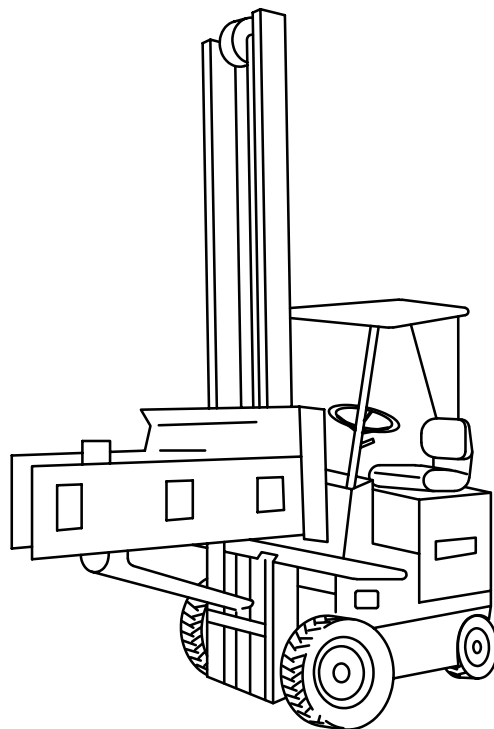

Figure 8 — Lateral-stacking truck

3.9 lateral- and front-stacking truck

turret truck

<three sides> high-lift stacking truck capable of stacking and retrieving loads ahead of and on either or both sides

Note 1 to entry: See [Figure 9](#).

Note 2 to entry: For equivalent terms in German, Chinese and Italian, see [A.9](#).

Note 3 to entry: Lateral-stacking trucks used in very narrow aisles (VNA) are guided mechanically on rails or guided inductively on a reference wire.

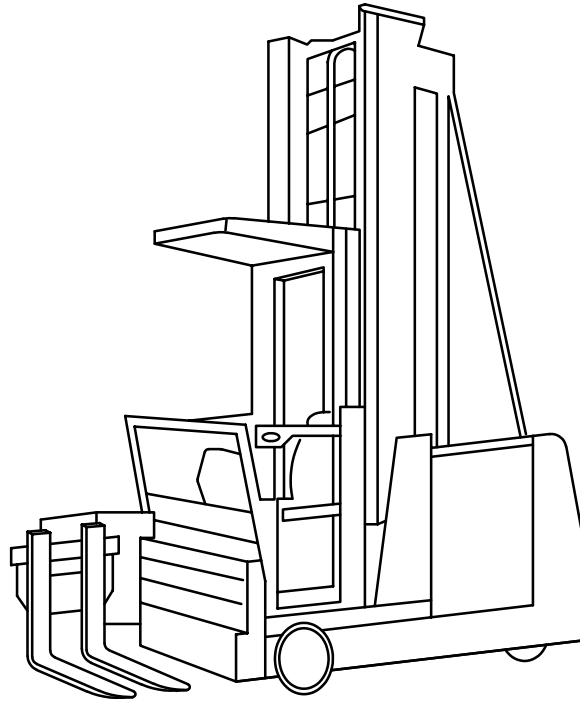

Figure 9 — Lateral- and front-stacking truck

3.10 order-picking truck

lift truck fitted with an operator's platform which can be raised with the platform or fork arms, allowing the operator to load or unload goods from racking to the load-carrying attachment

Note 1 to entry: See [Figure 10](#).

Note 2 to entry: For equivalent terms in German, Chinese and Italian, see [A.10](#).

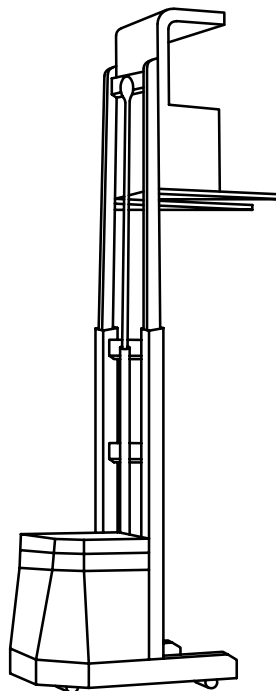

Figure 10 — Order-picking truck

3.11

straddle truck

stacking lift truck with outriggers, fitted with fork arms which are located between the outriggers and where the load centre of gravity is always within the stability polygon

Note 1 to entry: See [Figure 11](#).

Note 2 to entry: For equivalent terms in German, Chinese and Italian, see [A.11](#).

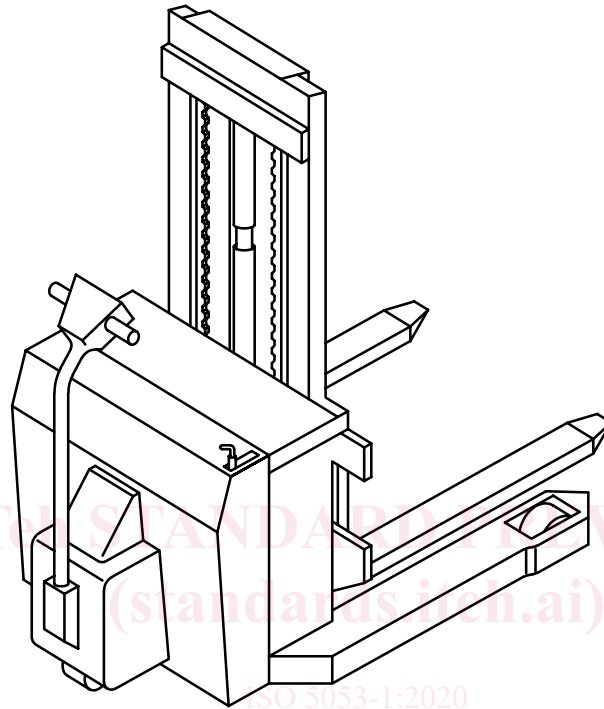

Figure 11 — Straddle truck

3.12

pallet-stacking truck

stacking lift truck where the forks extend over the frame structure

Note 1 to entry: See [Figure 12](#).

Note 2 to entry: For equivalent terms in German, Chinese and Italian, see [A.12](#).

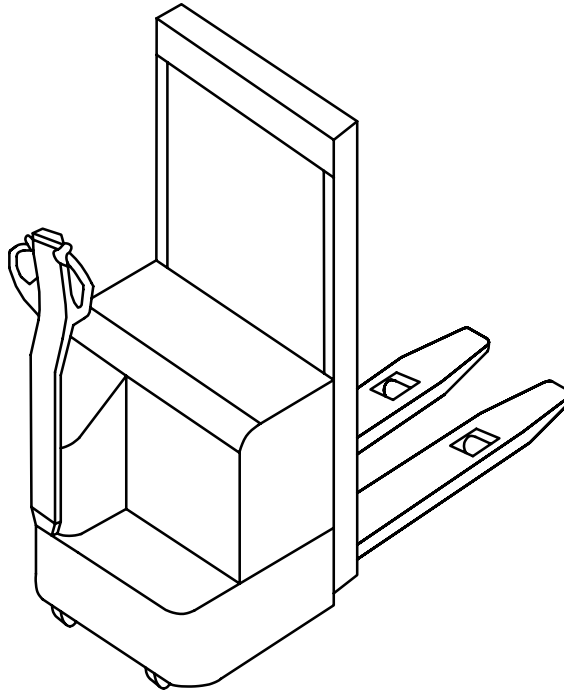

Figure 12 — Pallet-stacking truck

3.13

pallet truck

pedestrian-controlled or rider-controlled non-stacking lift truck fitted with forks

Note 1 to entry: See [Figure 13](#).

Note 2 to entry: For equivalent terms in German, Chinese and Italian, see [A.13](#).

Note 3 to entry: Trucks with a lift height up to 1 m for ergonomic picking of goods are pallet trucks.

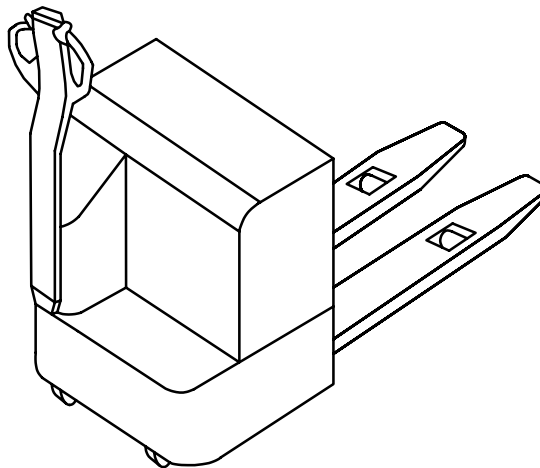

Figure 13 — Pallet truck

3.14

platform and stillage truck

pedestrian-controlled or rider-controlled non-stacking lift truck fitted with a load-carrying platform or structure

Note 1 to entry: See [Figure 14](#).

Note 2 to entry: For equivalent terms in German, Chinese and Italian, see [A.14](#).

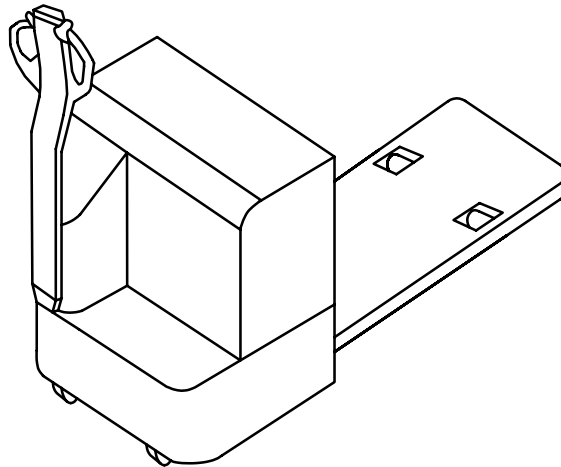

Figure 14 — Platform and stillage truck

3.15

end-controlled pallet truck

rider-controlled truck, non-stacking fitted with forks, with the operator located at the end opposite the load end of the truck and facing at a right angle to the path of travel

Note 1 to entry: See [Figure 15](#).

Note 2 to entry: For equivalent terms in German, Chinese and Italian, see [A.15](#).

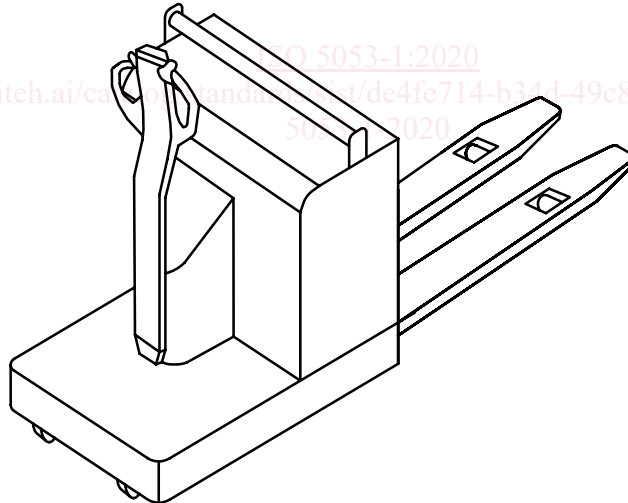

Figure 15 — End-controlled pallet truck

3.16

centre-controlled order-picking truck pallet truck

rider-controlled, non-stacking lift truck fitted with forks

Note 1 to entry: See [Figure 16](#).

Note 2 to entry: For equivalent terms in German, Chinese and Italian, see [A.16](#).

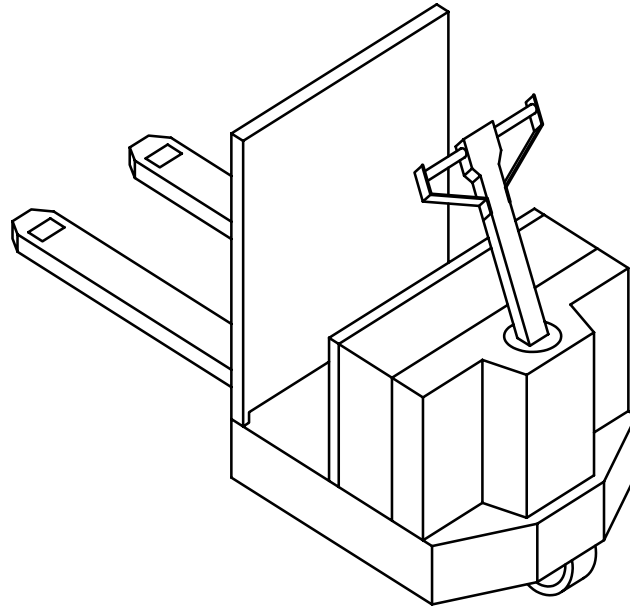

Figure 16 — Centre-controlled order-picking truck

3.17

double-stacker

stacking industrial truck where the forks extend over the lifttable support arms, designed for transport and loading of two loads positioned on top of each other, whereby the loads are lifted and lowered independently, one on the support arms and the other on the forks

Note 1 to entry: See [Figure 17](#).

Note 2 to entry: For equivalent terms in German, Chinese and Italian, see [A.17](#). ISO 5053-1:2020

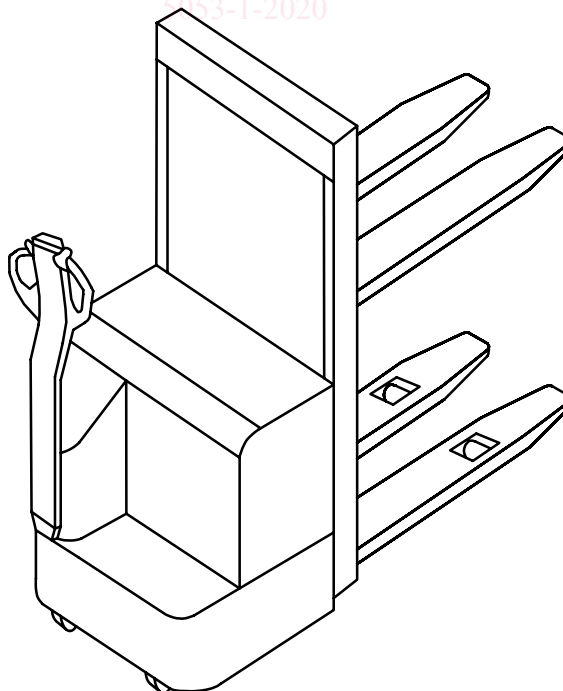

Figure 17 — Double-stacker