



Designation: D892 – 10

British Standard 5092



Designation: 146/2000

## Standard Test Method for Foaming Characteristics of Lubricating Oils<sup>1</sup>

This standard is issued under the fixed designation D892; the number immediately following the designation indicates the year of original adoption or, in the case of revision, the year of last revision. A number in parentheses indicates the year of last reapproval. A superscript epsilon ( $\epsilon$ ) indicates an editorial change since the last revision or reapproval.

*This standard has been approved for use by agencies of the Department of Defense.*

### 1. Scope\*

1.1 This test method covers the determination of the foaming characteristics of lubricating oils at 24°C and 93.5°C. Means of empirically rating the foaming tendency and the stability of the foam are described.

1.2 The values stated in SI units are to be regarded as the standard. The values given in parentheses are for information only.

1.3 *This standard does not purport to address all of the safety concerns, if any, associated with its use. It is the responsibility of the user of this standard to establish appropriate safety and health practices and determine the applicability of regulatory limitations prior to use.* For specific warning statements, see Sections 7, 8, and 9.1.1.

### 2. Referenced Documents

2.1 *ASTM Standards:*<sup>2</sup>

[D445 Test Method for Kinematic Viscosity of Transparent and Opaque Liquids \(and Calculation of Dynamic Viscosity\)](#)

[D6082 Test Method for High Temperature Foaming Characteristics of Lubricating Oils](#)

[E1 Specification for ASTM Liquid-in-Glass Thermometers](#)

[E128 Test Method for Maximum Pore Diameter and Permeability of Rigid Porous Filters for Laboratory Use](#)

[E1272 Specification for Laboratory Glass Graduated Cylinders](#)

### 3. Terminology

3.1 *Definitions:*

3.1.1 *diffuser, n—for gas*, a device for dispersing gas into a fluid.

3.1.1.1 *Discussion*—In this test method the diffuser may be made of either metallic or non-metallic materials.

3.1.2 *entrained air (or gas), n—in liquids*, a two-phase mixture of air (or gas) dispersed in a liquid in which the liquid is the major component on a volumetric basis.

3.1.2.1 *Discussion*—Entrained air (or gas) may form micro size bubbles in liquids that are not uniformly dispersed and that may coalesce to form larger bubbles below or at the surface which break or form foam.

3.1.3 *foam, n—in liquids*, a collection of bubbles formed in or on the surface of a liquid in which the air or gas is the major component on a volumetric basis.

3.1.4 *lubricant, n*—any material interposed between two surfaces that reduces friction or wear between them. **D6082**

3.1.4.1 *Discussion*—In this test method, the lubricant is an oil which may or may not contain additives such as foam inhibitors.

3.1.5 *maximum pore diameter, n—in gas diffusion*, the diameter of a circular cross-section of a capillary is equivalent to the largest pore of the diffuser under consideration.

3.1.5.1 *Discussion*—The pore dimension is expressed in micrometres ( $\mu\text{m}$ ).

3.1.6 *permeability, n—in gas diffusion*, the rate of a substance that passes through a material (diffuser) under given conditions.

3.2 *Definitions of Terms Specific to This Standard:*

3.2.1 *dynamic bubble, n*—the first bubble to pass through and escape from the diffuser followed by a continuous succession of bubbles when testing for the maximum pore diameter in **Annex A1**.

<sup>1</sup> This test method is under the jurisdiction of ASTM Committee D02 on Petroleum Products and Lubricants and is the direct responsibility of Subcommittee D02.06 on Analysis of Lubricants.

Current edition approved Oct. 1, 2010. Published November 2010. Originally approved in 1946. Last previous edition approved in 2006 as D892–06<sup>ε1</sup>.

In the IP, this test method is under the jurisdiction of the Standardization Committee. This test method has been approved by the sponsoring committees and accepted by the cooperating societies in accordance with established procedures. DOI: 10.1520/D0892-10.

<sup>2</sup> For referenced ASTM standards, visit the ASTM website, www.astm.org, or contact ASTM Customer Service at service@astm.org. For *Annual Book of ASTM Standards* volume information, refer to the standard's Document Summary page on the ASTM website.

\*A Summary of Changes section appears at the end of this standard.

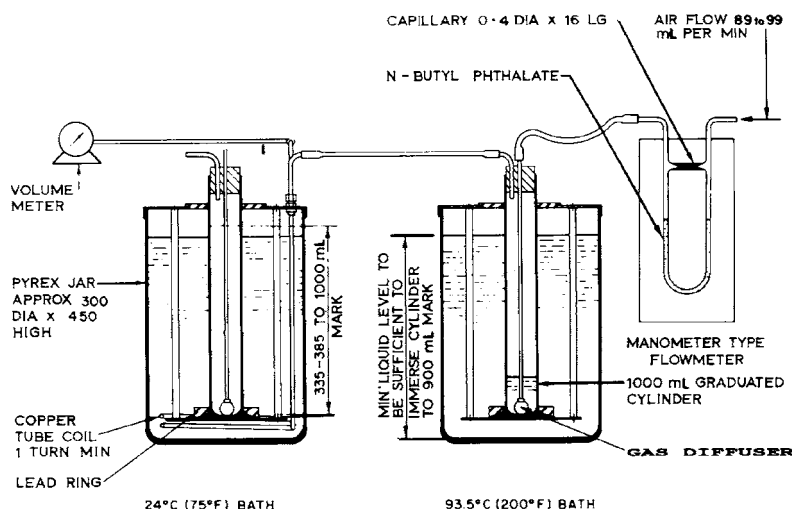

All dimensions in millimetres.  
**FIG. 1 Foaming Test Apparatus**

3.2.1.1 *Discussion*—When a diffuser is immersed in a liquid, air can be trapped in the pores. It can escape eventually or as soon as a pressure is applied to the diffuser. When testing for maximum pore diameter (**Annex A1**) the escape of such bubble shall be ignored.

3.2.2 *foam stability, n*—in foam testing, the amount of foam remaining at the specified time following the disconnecting of the air supply.

3.2.2.1 *Discussion*—In this test method, foam stability is determined from measurements made 10 min ± 10 s after disconnecting the air supply. In cases after the air supply has been disconnected, where the foam collapses to 0 mL before the 10 min settling time has elapsed, the test may be terminated and the foam stability result recorded as 0 mL.

3.2.3 *foaming tendency, n*—in foam testing, the amount of foam determined from measurements made immediately after the cessation of air flow.

#### 4. Summary of Test Method

4.1 *Sequence I*—A portion of sample, maintained at a bath temperature of 24 ± 0.5°C is blown with air at a constant rate (94 ± 5 mL/min) for 5 min, then allowed to settle for 10 min (unless the case described in 3.2.2.1 applies, in which case, the time duration can be shortened). The volume of foam is measured at the end of both periods.

4.2 *Sequence II*—A second portion of sample, maintained at a bath temperature of 93.5 ± 0.5°C, is analyzed using the same air flow rate and blowing and settling time duration as indicated in 4.1.

4.3 *Sequence III*—The sample portion used in conducting Sequence II is used for Sequence III, where any remaining foam is collapsed and the sample portion temperature cooled below 43.5°C by allowing the test cylinder to stand in air at room temperature, before placing the cylinder in the bath maintained at 24 ± 0.5°C. The same air flow rate and blowing and settling time duration as indicated in 4.1 is followed.

#### 5. Significance and Use

5.1 The tendency of oils to foam can be a serious problem in systems such as high-speed gearing, high-volume pumping, and splash lubrication. Inadequate lubrication, cavitation, and overflow loss of lubricant can lead to mechanical failure. This test method is used in the evaluation of oils for such operating conditions.

#### 6. Apparatus

6.1 *Foaming Test Apparatus*, an example of a suitable set-up is shown in Fig. 1, consisting of a 1000-mL graduated cylinder or cylinders (meeting Specification E1272 class B tolerance requirement of ±6 mL and at least graduations of 10 mL) held in position when placed in the baths, such as fitted with a heavy ring or clamp assembly to overcome the buoyancy, and an air-inlet tube, to the bottom of which is fastened a gas diffuser. The gas diffuser can be either a 25.4-mm (1-in.) diameter spherical gas diffuser stone made of fused crystalline alumina grain, or a cylindrical metal diffuser made of sintered five micron porous stainless steel (**Note 1**). The cylinder shall have a diameter such that the distance from the inside bottom to the 1000-mL graduation mark is 360 ± 25 mm. It shall be circular at the top (**Note 2**) and shall be fitted with a stopper, such as those made of rubber, having one hole at the center for the air-inlet tube and a second hole off-center for an air-outlet tube. The air-inlet tube shall be adjusted so that, when the stopper is fitted tightly into the cylinder, the gas diffuser (**Note 3**) just touches the bottom of the cylinder and is approximately at the center of the circular cross section. Gas diffusers shall meet the following specification when tested in accordance with the method given in **Annex A1**:

Maximum pore diameter, μm	Not greater than 80
Permeability at pressure of 2.45 kPa (250 mm) water, mL of air/min	3000 to 6000

**NOTE 1**—Gas diffuser permeability and porosity can change during use; therefore, it is recommended that diffusers be tested when new and periodically thereafter preferably after each use.

**NOTE 2**—Graduated cylinders with circular tops can be prepared from

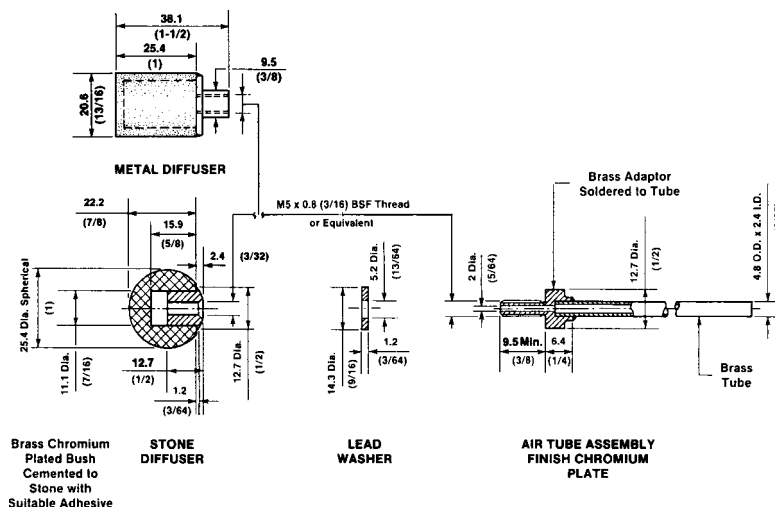

FIG. 2 Attachment of Gas Diffusers to Air-Inlet Tubes

cylinders with pouring spouts by cutting them off below the spouts. The cut surface is to be smoothed before use by fire polishing or grinding.

NOTE 3—Gas diffusers may be attached to air-inlet tubes by any suitable means. A convenient arrangement is shown in Fig. 2.

NOTE 4—It may be necessary to confirm the volume of the cylinder.

6.2 *Test Baths*, large enough to permit the immersion of the cylinder at least to the 900-mL mark and capable of being maintained at temperatures constant to 0.5°C (1°F) at 24°C (75°F) and 93.5°C (200°F), respectively. Both bath (NOTE 6) and bath liquid shall be clear enough to permit observation of the graduations on the cylinder.

NOTE 5—Air baths may also be utilized for heating purposes. Limited data has shown that both liquid and air baths give equivalent results. However, the precision estimates given in Section 13 are based on using only liquid baths.<sup>3</sup>

NOTE 6—Heat-resistant cylindrical glass jars approximately 300 mm (12 in.) in diameter and 450 mm (18 in.) in height make satisfactory baths.

6.3 *Air Supply*, from a source capable of maintaining an air flow rate of  $94 \pm 5$  mL/min through the gas diffuser. The air shall be passed through a drying tower 300 mm in height packed as follows: just above the constriction place a 20-mm layer of cotton, then a 180-mm layer of indicating desiccant, and a 20-mm layer of cotton. The cotton serves to hold the desiccant in place. Refill the tower when the indicating desiccant begins to show presence of moisture. A flowmeter sensitive to the required tolerances can be used to measure the air flow (NOTE 7).

NOTE 7—A manometer type flowmeter, in which the capillary between the two arms of the U-tube is approximately 0.4 mm in diameter and 16 mm in length, and in which *n*-butylphthalate is the manometric liquid, is suitable.

6.3.1 The total volume of air leaving the foaming test apparatus shall be measured by a volume measuring device (NOTE 9) capable of accurately measuring gas volumes of about 470 mL. The air shall be passed through at least one loop of

copper tubing placed around the inside circumference of the cold bath so that the volume measurement is made at approximately 24°C (75°F). Precautions are to be taken to avoid leaks at any point in the system.

NOTE 8—Alternatively, a 1 L cylinder (with 10 mL graduation marks) full of water is inverted in a tall, large beaker also filled with water. There should be no air bubbles inside. Air leaving the copper loop in the bath is connected below the cylinder. When the test is started, air will flow into the cylinder, displacing the water. At the end of the test, the volume of air in the cylinder is measured by equalizing the water levels inside and outside the cylinder. Alternatively, the total volume of air passed would be the difference between the final and the initial volumes of water in the cylinder.

NOTE 9—A wet test meter calibrated in hundredths of a litre is suitable.

6.4 *Timer*, graduated and accurate to 1 s or better.

6.5 *Temperature Sensing Device*, capable of covering the temperature range from at least 20 to 100°C, with an accuracy of  $\pm 0.5^\circ\text{C}$ . A thermometer having a range as shown below and conforming to the requirements as prescribed in Specification E1 or specifications for IP thermometers has been found suitable to use:

Temperature Range	Thermometer	No. IP
20 to 102°C	ASTM 12C	64C

## 7. Reagents and Materials

7.1 *Purity of Reagents*—Reagent grade chemicals shall be used in all cases. Unless indicated otherwise, it is intended that all reagents conform to the specifications of the committee on Analytical Reagents of the American Chemical Society where such specifications are available.<sup>4</sup> Other grades may be used, provided it is first ascertained that the reagent is of sufficiently high purity to permit its use without lessening the accuracy of the determination.

<sup>4</sup> *Reagent Chemicals, American Chemical Society Specifications*, American Chemical Society, Washington, DC. For Suggestions on the testing of reagents not listed by the American Chemical Society, see *Annual Standards for Laboratory Chemicals*, BDH Ltd., Poole, Dorset, U.K., and the *United States Pharmacopeia and National Formulary*, U.S. Pharmacopeial Convention, Inc. (USPC), Rockville, MD.

<sup>3</sup> Supporting data have been filed at ASTM International Headquarters and may be obtained by requesting Research Report RR:D02-1516.

7.2 *Acetone*—(**Warning**—Extremely flammable, vapors can cause a flash fire).

7.3 *Compressed Air*, hydrocarbon free and dry to a dew point of  $-60^{\circ}\text{C}$  or lower.

NOTE 10—If the source of compressed air is ensured to the stated specifications, the drying tower in 6.3 may not be necessary.

7.4 *Heptane*—(**Warning**—Flammable, vapor harmful).

7.5 *Propan-2-ol*—(Solvents with equivalent cleaning and solvency characteristics may be substituted for propan-2-ol.)

7.6 *Toluene (Methylbenzene)*—(Solvents with equivalent cleaning and solvency characteristics may be substituted for toluene.)

## 8. Hazards

8.1 (**Warning**—Users of this test method shall be trained and familiar with all normal laboratory practices, or under the immediate supervision of such a person. It is the responsibility of the operator to ensure that all local legislative and statutory requirements are met.)

8.2 (**Warning**—Cleaning solvents have flash points lower than ambient temperatures. Avoid the possibility of fire or explosion.)

8.3 (**Warning**—The fumes from the test oil and the bath shall be vented in a manner compatible with local government regulations.)

8.4 (**Warning**—Some apparatus assemblies can have as much as 20 L of heat transfer oil at  $93.5^{\circ}\text{C}$ . Therefore, in the event of breakage of the containing vessel, provisions for suitable containment of the spill is advisable.)

## 9. Preparation of Apparatus

9.1 Thorough cleansing of the test cylinder and air-inlet tube is essential after each use to remove any additive remaining from previous tests which can seriously interfere with results of subsequent tests.

9.1.1 *Cylinder*—Rinse the cylinder with heptane. (**Warning**—Flammable, vapor harmful.) Wash the cylinder with a suitable detergent. Rinse the cylinder, in turn, with distilled water, then acetone (**Warning**—Extremely flammable, vapors can cause a flash fire) and dry in a current of the compressed air or in a drying oven. Interior walls that drain the water cleanly, that is without drops forming, are adequately cleaned.

NOTE 11—Certain detergents are notorious for adhering to glass; therefore, it is important to realize that such a circumstance can affect the test result. Several rinsings with water and acetone may be required.

9.1.2 *Gas Diffuser and Air Tube*—Clean the gas diffuser with toluene (solvents with equivalent cleaning and solvency characteristics may be substituted for toluene.) and heptane. Immerse the gas diffuser in about 300 mL of toluene. Flush a portion of the toluene back and forth through the gas diffuser at least five times with vacuum and air pressure. Repeat the process with heptane. After the final washing, dry both the tube and the gas diffuser thoroughly by forcing clean air through them. Wipe the outside of the air inlet tube, first with a cloth moistened with heptane, then a dry cloth. Do not wipe the gas diffuser.

NOTE 12—Certain samples may contain ingredients which may not be adequately removed by this process and, because these can affect the next test, more rigorous cleaning may be required; this is recommended. When alternate diffuser cleaning methods are used certain cautions should be observed: (1) Non-metallic diffusers may have absorbed as well as adsorbed these interfering ingredients or the cleaners, or both, and this shall be considered before proceeding to the next test. (2) So that all tests performed start off under the same circumstances, when alternate diffuser cleaning methods are used, the final rinsing process shall be as detailed in 9.1.2. (3) See also Note 1.

## 10. Procedure

10.1 *Sequence I*—Without mechanical shaking or stirring, decant approximately 200 mL of sample into a beaker (see 10.1.1). Heat to  $49 \pm 3^{\circ}\text{C}$  and allow to cool to  $24 \pm 3^{\circ}\text{C}$ . See Option A for stored sample (see 10.5). Each step of the procedure described in 10.3 and 10.4, respectively, shall be carried out within 3 h after completion of the previous step. In 10.5.1, the test shall be carried out as soon as compatible with the temperature specification and not more than 3 h after immersion of the cylinder in the  $93.5^{\circ}\text{C}$  ( $200^{\circ}\text{F}$ ) bath.

10.1.1 If a sample arrives in the lab and it has been determined that it is at or above  $49 \pm 3^{\circ}\text{C}$ , the heating step in 10.1 may be eliminated. Heating the sample to  $49 \pm 3^{\circ}\text{C}$  in 10.1 is intended to remove any thermal history before proceeding, which is not an issue for samples arriving in the lab already at or above  $49 \pm 3^{\circ}\text{C}$ .

10.2 Pour the sample into the 1000-mL cylinder until the liquid level is at the 190-mL mark. Visually estimate the level to be within 5 mL. Immerse the cylinder at least to the 900-mL mark in the bath maintained at  $24 \pm 0.5^{\circ}\text{C}$  ( $75 \pm 1^{\circ}\text{F}$ ). When the oil has reached the bath temperature, insert the gas diffuser and the air-inlet tube with the air source disconnected, and permit the gas diffuser to soak for about 5 min. Connect the air-outlet tube to the air volume measuring device. At the end of 5 min, connect to the air source, adjust the air flow rate to  $94 \pm 5$  mL/min, and force clean dry air through the gas diffuser for  $5 \text{ min} \pm 3 \text{ s}$ , timed from the first appearance of air bubbles rising from the gas diffuser. At the end of this period, shut off the air flow by disconnecting the hose from the flow meter and immediately record the volume of foam; that is, the volume between the oil level and the top of the foam. The total air volume which has passed through the system shall be  $470 \pm 25$  mL. Allow the cylinder to stand for  $10 \text{ min} \pm 10 \text{ s}$  and again record the volume of foam (see 10.2.1).

10.2.1 In cases after the air supply has been disconnected, where the foam collapses to 0 mL before the 10 min settling time has elapsed, the test may be terminated and the foam stability result recorded as 0 mL.

10.3 *Sequence II*—Pour a second portion of sample into a cleaned 1000-mL cylinder until the liquid level is at the 180-mL mark. Visually estimate the level to be within 5 mL. Immerse the cylinder at least to the 900-mL mark in the bath maintained at  $93.5 \pm 0.5^{\circ}\text{C}$  ( $200 \pm 1^{\circ}\text{F}$ ). When the oil has reached a temperature of  $93 \pm 1^{\circ}\text{C}$ , insert a clean gas diffuser and air-inlet tube and proceed as described in 10.2, recording the volume of foam at the end of the blowing and settling periods. In cases where 10.2.1 applies, the test procedure may continue to Sequence III.

10.4 *Sequence III*—Collapse any foam remaining after the test at 93.5°C (200°F) (10.3), by stirring. Cool the sample to a temperature below 43.5°C (110°F) by allowing the test cylinder to stand in air at room temperature, then place the cylinder in the bath maintained at 24 ± 0.5°C (75 ± 1°F). After the oil has reached bath temperature, insert a cleaned air-inlet tube and gas diffuser and proceed as described in 10.2, recording the foam value at the end of the blowing and settling periods. (See 10.2.1.)

10.5 Some lubricants with modern additives can pass their foam requirements when blended (with the antifoam properly dispersed in small particle sizes) but fail to meet the same requirements after two or more weeks' storage. (It appears that the polar dispersant additives have the potency to attract and hold antifoam particles, such that the apparent increased antifoam size results in decreased effectiveness to control foam in Test Method D892.) However, if the same stored oil is merely decanted and poured into engines, transmissions, or gear boxes and those units operated for a few minutes, the oil again meets its foam targets. Similarly, *decanting* the stored oil into a blender, followed by agitation as described for Option A (see 10.5.1), redisperses the antifoam held in suspension and the oil again will give good foam control in Test Method D892. For such oils, Option A can be used. On the other hand, if the antifoam is not dispersed into sufficiently small particles when the oil is blended, the oil cannot meet its foam requirements. If this freshly blended oil were vigorously stirred according to Option A, it is very possible that the oil would then meet its foam targets whereas the plant blend would never do so. Therefore, it is inappropriate and misleading to apply Option A for quality control of freshly made blends.

10.5.1 *Option A*—Clean the container of a 1-L (1-qt), high-speed blender using the procedure given in 9.1.1. Place 500 mL of sample measured from 18 to 32°C (65 to 90°F) into the container, cover, and stir at maximum speed for 1 min. Because it is normal for considerable air to be entrained during this agitation, allow to stand until entrained bubbles have dispersed and the temperature of the oil has reached 24 ± 3°C (75 ± 5°F). Within 3 h following the agitation (solvents with equivalent cleaning and solvency characteristics may be substituted for toluene), start with testing as specified in 10.2.

NOTE 13—In case of viscous oils, 3 h can be insufficient time to disperse the entrained air. If a longer time is required, record the time as a note on the results.

11. Alternative Procedure

11.1 For routine testing a simplified testing procedure can be used. This procedure differs from the standard method in only one respect. The total air volume used during the 5-min blowing period is not measured after the air has passed through the gas diffuser. This eliminates the volume measuring equipment and the airtight connections necessary to carry the exit air from the graduated cylinder to the volume measuring device, but requires that the flowmeter be correctly calibrated and that the flow rate be carefully controlled. Results obtained by this procedure shall be reported as D892 – IP 146 (Alternative).

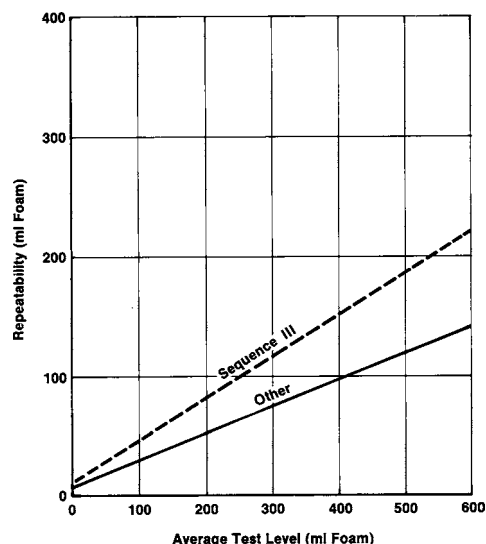

FIG. 3 Precision Chart—Repeatability

12. Report

12.1 Report the data in the following manner:

Test	Foaming Tendency ASTM D892 IP 146	Foam Stability ASTM D892 IP 146
	Foam Volume, mL, at end of 5-min blowing period	Foam Volume, mL, at end of 10-min settling period
As received:		
Sequence I	...	...
Sequence II	...	...
Sequence III	...	...
After agitation: (Option A, 9.5.1)		
Sequence I	...	...
Sequence II	...	...
Sequence III	...	...

12.2 For the purpose of reporting results, when the bubble layer fails to completely cover the oil surface and a patch or eye of clear fluid is visible, the value shall be reported as nil foam.

13. Precision and Bias<sup>5</sup>

13.1 *Precision*—The precision values in this statement were determined in a cooperative laboratory program.<sup>6</sup>

13.1.1 *Repeatability*—The difference between successive results obtained by the same operator with the same apparatus under constant operating conditions on identical test material would, in the long run, in the normal and correct operation of the test method exceed the following values in only one case in twenty (see Fig. 3).

13.1.2 *Reproducibility*—The difference between two single and independent results obtained by different operators working in different laboratories on identical test material would, in the long run, exceed the following values in only one case in twenty (see Fig. 4).

NOTE 14—The dashed lines in Fig. 3 and Fig. 4 are for foam stability of Sequence III and the solid lines are for foam height for Sequences I, II,

<sup>5</sup> Supporting data have been filed at ASTM International Headquarters and may be obtained by requesting Research Report RR:D02-1244.

<sup>6</sup> Filed at ASTM International Headquarters and may be obtained by requesting Research Report RR:D02-1007.

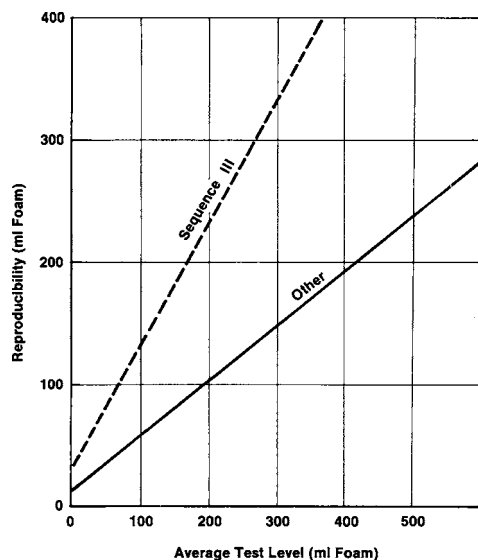

FIG. 4 Precision Chart—Reproducibility

and III and foam stability for Sequences I and II.

13.1.3 For those oils which have been tested by Option A (10.5.1), no precision statement is yet available.

NOTE 15—The majority of the results in the cooperative work that led to Option A were nil foam; hence, no precision statement can be calculated.

13.2 Bias—Since there is no accepted reference material suitable for determining the bias for the procedure for measuring foaming characteristics in Test Method D892, bias cannot be determined.

14. Keywords

14.1 foam (foaming)

ANNEX

(Mandatory Information)

A1. TEST FOR MAXIMUM PORE DIAMETER AND PERMEABILITY OF GAS DIFFUSERS (BASED ON TEST METHOD E128)

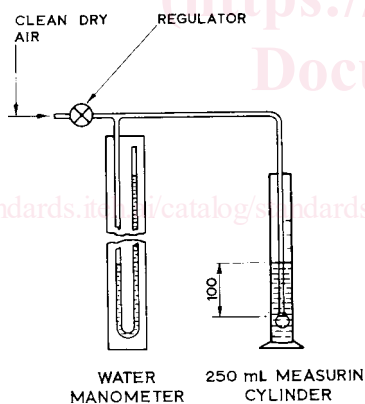

FIG. A1.1 Apparatus for Measuring Maximum Pore Size

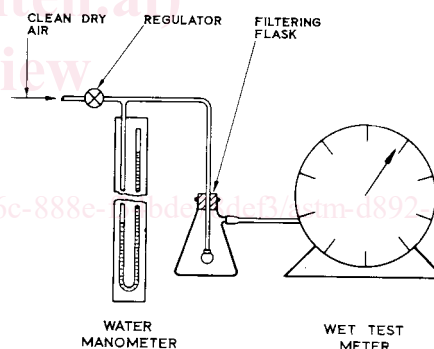

FIG. A1.2 Apparatus for Measuring Permeability

A1.1 Apparatus

A1.1.1 Apparatus for the maximum pore diameter determination consists of a regulated source of clean, dry, compressed air, a U-tube water manometer of sufficient length to read a pressure differential of 7.85 kPa (800 mm of water) and a cylinder of a size sufficient (250 mL is suitable) to conveniently immerse a gas diffuser to a depth of 100 mm (see Fig. A1.1).

A1.1.2 Additional apparatus for permeability determination consists of a gas volume metre of sufficient capacity to measure flow rates of at least 6000 mL/min while generating a back pressure of no more than 10 mm water. A filtering flask large enough that the 25.4-mm (1-in.) diameter diffuser will pass through the neck. This flask shall be fitted with a rubber stopper with a single hole to admit the air-inlet tube (see Fig. A1.2). A

supply of tubing having an internal diameter of 8 mm (0.3 in.) shall be used to make the connections between the various parts of the apparatus as shown in Fig. A1.1 and Fig. A1.2.

A1.2 Procedure

A1.2.1 Maximum Pore Diameter—Connect the diffuser to the manometer using an adaptor as shown in Fig. 2 (but without the brass tubing) and a 1.0-m length of 8-mm bore tubing. Support the clean diffuser to a depth of 100 mm, as measured to the top of the diffuser, in distilled water if the diffuser is non-metallic and propan-2-ol if the diffuser is metallic. Allow to soak for at least 2 min. Connect the air-inlet tube to a controllable source of clean, compressed air as shown in Fig. A1.1. Increase the air pressure at a rate of about 490 Pa (50 mm of water)/min until the first dynamic bubble passes through the filter and rises through the water. The first dynamic