



Designation: D5615 – 07^{ε1}

Standard Test Method for Operating Characteristics of Home Reverse Osmosis Devices¹

This standard is issued under the fixed designation D5615; the number immediately following the designation indicates the year of original adoption or, in the case of revision, the year of last revision. A number in parentheses indicates the year of last reapproval. A superscript epsilon (ϵ) indicates an editorial change since the last revision or reapproval.

^{ε1} NOTE—Added research report information to Section 10 editorially in November 2010.

1. Scope

1.1 This test method covers determination of the operating characteristics of home reverse osmosis devices using standard test conditions. It does not necessarily determine the characteristics of the devices operating on natural waters.

1.2 This test method is applicable for spiral-wound devices.

1.3 The values stated in SI units are to be regarded as the standard. The values given in parentheses are for information only.

1.4 *This standard does not purport to address all of the safety concerns, if any, associated with its use. It is the responsibility of the user of this standard to establish appropriate safety and health practices and determine the applicability of regulatory limitations prior to use.*

2. Referenced Documents

2.1 *ASTM Standards:*²

- D512 Test Methods for Chloride Ion in Water
- D1125 Test Methods for Electrical Conductivity and Resistivity of Water
- D1129 Terminology Relating to Water
- D1193 Specification for Reagent Water
- D1293 Test Methods for pH of Water
- D2777 Practice for Determination of Precision and Bias of Applicable Test Methods of Committee D19 on Water
- D4194 Test Methods for Operating Characteristics of Reverse Osmosis and Nanofiltration Devices
- D4516 Practice for Standardizing Reverse Osmosis Performance Data
- D6161 Terminology Used for Microfiltration, Ultrafiltration,

¹ This test method is under the jurisdiction of ASTM Committee D19 on Water and is the direct responsibility of Subcommittee D19.08 on Membranes and Ion Exchange Materials.

Current edition approved June 15, 2007. Published July 2007. Originally approved in 1994. Last previous edition approved in 2001 as D5615 – 95 (2001). DOI: 10.1520/D5615-07E01.

² For referenced ASTM standards, visit the ASTM website, www.astm.org, or contact ASTM Customer Service at service@astm.org. For *Annual Book of ASTM Standards* volume information, refer to the standard's Document Summary page on the ASTM website.

Nanofiltration and Reverse Osmosis Membrane Processes

3. Terminology

3.1 *Definitions*—For definitions of terms used in this test method, refer to Terminology D1129. For descriptions of terms relating to reverse osmosis, refer to Test Methods D4194 and D6161.

4. Summary of Test Method

4.1 This test method consists of determining the permeate flow rate and sodium chloride rejection for reverse osmosis devices at 345-kPa (50-psi) feed gage pressure, 25°C and 22 % conversion using an aqueous 300-mg/L sodium chloride solution.

5. Significance and Use

5.1 Home reverse osmosis devices are typically used to remove salts and other impurities from drinking water at the point of use. They are usually operated at tap water line pressure, with water containing up to several hundred milligrams per litre of total dissolved solids. This test method permits measurement of the performance of home reverse osmosis devices using a standard set of conditions and is intended for short-term testing (less than 24 h). This test method can be used to determine changes that may have occurred in the operating characteristics of home reverse osmosis devices during use, but it is not intended to be used for system design. This test method does not necessarily determine the device's performance when solutes other than sodium chloride are present. Use Practice D4516 and Test Methods D4194 to standardize actual field data to a standard set of conditions.

5.2 This test method is applicable for spiral-wound devices.

6. Apparatus

6.1 The apparatus for the test method is described schematically in Fig. 1. A conductivity meter can be used to determine the salt concentration in accordance with Test Methods D1125.

6.2 *Installation:*

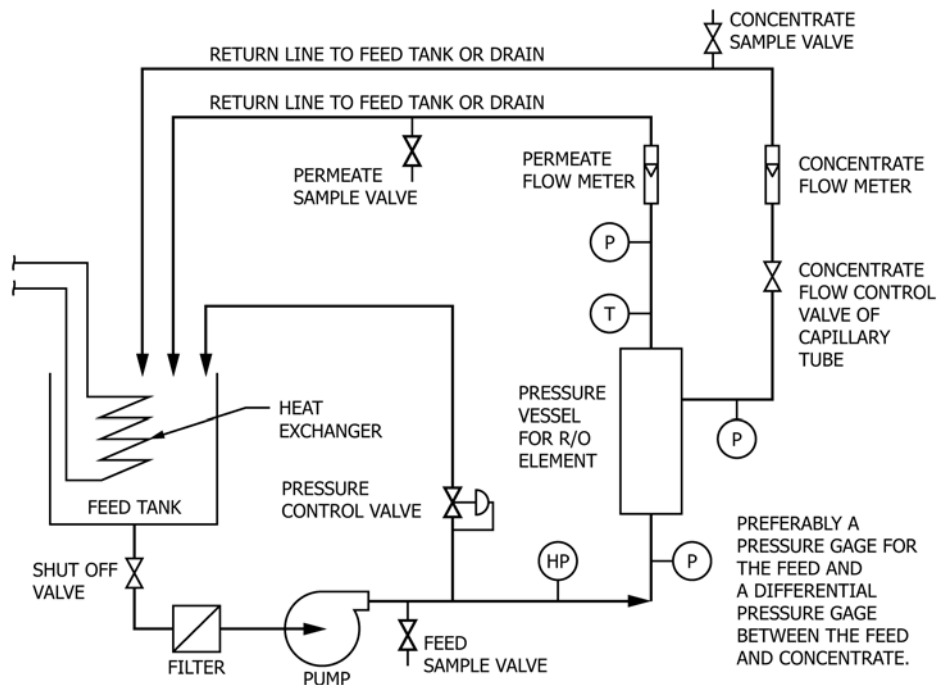

P – PRESSURE TAP LOCATION
 T – TEMPERATURE MEASUREMENT LOCATION
 HP – HIGH PRESSURE SHUTOFF PROBE LOCATION

FIG. 1 Flow Schematic of Testing Apparatus

6.2.1 Materials of construction shall preferably be of plastic or stainless steel (use 316 or better to minimize corrosion) for all wetted parts to prevent contamination of the feed solution by corrosion products. Do not use reactive piping material such as plain carbon steel, galvanized or cadmium-plated carbon steel, and cast iron for piping. Ensure that no contamination will occur from oil films on new metal piping, release agents on raw plastic components, or feed solutions used in the system previously. Whether stainless steel or plastic, all pressurized components should be designed based on the manufacturer's working pressure rating. Review the manufacturer's rating for compliance with standard engineering practice.

6.2.2 The reverse osmosis testing apparatus is represented schematically in Fig. 1. It consists of a feed holding tank equipped with a thermostated heat exchanger system to maintain the feed solution at the desired temperature, a centrifugal pump, and a home reverse osmosis device. The feed tank is at a higher level than the pump to keep the pump suction flooded. Use a valve with minimum flow restriction to prevent excessive pressure drop (for example, a ball valve or plug valve) for a shut-off valve. The filter can be either a strainer (100 mesh) or a 25- μm filter (based on the supplier's recommendation). The pressure control valve is a back pressure regulator but can be substituted with a manually operated needle valve. The concentrate flow is controlled with a needle valve or a capillary tube. The high-pressure shutoff should have a cutoff point at a gage pressure of approximately 690 kPa (100 psi) or lower if any part of the pressurized system cannot withstand this pressure. The testing apparatus shall be cleaned thoroughly before use to remove contaminants, including microorganisms.

6.3 Instrumentation:

6.3.1 See Fig. 1 for pressure tap locations. Locate these as close as possible to the reverse osmosis device. Use a calibrated transducer or a single gage equipped with a high-pressure "quick connect" or Taylor plug gage fitting for measuring individual pressures and the device pressure drop (ΔP). Individual gages are also satisfactory but are not as reliable as a quick-connect test gage or a special ΔP gage.

6.3.2 *Temperature*—The permeate temperature must be measured, and this should be accomplished close to the permeate port. The probe of calibrated dial thermometers or resistance thermometers should be immersed in the flowing permeate.

6.3.3 *Flow Meters*—Calibrated flow meters are used to measure the concentrate and permeate flows. Alternatively, the flows can be measured volumetrically using a calibrated graduated cylinder and a stopwatch.

6.3.4 pH Meter.

6.3.5 *Temperature-Compensated Conductivity/Resistivity Meter.*

6.4 *Operation*—Operate the apparatus by drawing the feed solution from the tank and pumping one part of it directly back to the tank by means of the pressure control valve and the other part through the reverse osmosis device under pressure. Return both the permeate stream and the concentrate stream to the feed tank so that its volume and solute concentration remain constant. Direct the return flows in the feed tank to provide adequate mixing. Use the heat exchanger coils in the feed tank