



SLOVENSKI STANDARD
oSIST prEN ISO 179-1:2022
01-junij-2022

Polimerni materiali - Ugotavljanje udarne žilavosti pa Charpyju - 1. del: Preskus udarne žilavosti z neinstrumentalno metodo (ISO/DIS 179-1:2022)

Plastics - Determination of Charpy impact properties - Part 1: Non-instrumented impact test (ISO/DIS 179-1:2022)

Kunststoffe – Bestimmung der Charpy-Schlageigenschaften – Teil 1: Nicht instrumentierte Schlagzähigkeitsprüfung (ISO/DIS 179-1:2022)

Plastiques - Détermination des caractéristiques au choc Charpy - Partie 1: Essai de choc non instrumenté (ISO/DIS 179-1:2022)

Ta slovenski standard je istoveten z: prEN ISO 179-1

<https://standards.iteh.ai/catalog/standards/sist/ebe0ddd1-2c4b-4937-9322-d333fef09495/osist-pren-iso-179-1-2022>

ICS:

83.080.01	Polimerni materiali na splošno	Plastics in general
-----------	--------------------------------	---------------------

oSIST prEN ISO 179-1:2022

en,fr,de

**iTeh STANDARD
PREVIEW
(standards.iteh.ai)**

oSIST prEN ISO 179-1:2022

<https://standards.iteh.ai/catalog/standards/sist/ebe0ddd1-2c4b-4937-9322-d333fef09495/osist-pren-iso-179-1-2022>

DRAFT INTERNATIONAL STANDARD

ISO/DIS 179-1

ISO/TC 61/SC 2

Secretariat: SAC

Voting begins on:
2022-04-12

Voting terminates on:
2022-07-05

Plastics — Determination of Charpy impact properties —

Part 1: Non-instrumented impact test

*Plastiques — Détermination des caractéristiques au choc Charpy —
Partie 1: Essai de choc non instrumenté*

ICS: 83.080.01

**iTeh STANDARD
PREVIEW
(standards.iteh.ai)**

[oSIST prEN ISO 179-1:2022
https://standards.iteh.ai/catalog/standards/sist/ebe0ddd1-
2c4b-4937-9322-d333fef09495/osist-pren-iso-179-1-
2022](https://standards.iteh.ai/catalog/standards/sist/ebe0ddd1-2c4b-4937-9322-d333fef09495/osist-pren-iso-179-1-2022)

This document is circulated as received from the committee secretariat.

THIS DOCUMENT IS A DRAFT CIRCULATED FOR COMMENT AND APPROVAL. IT IS THEREFORE SUBJECT TO CHANGE AND MAY NOT BE REFERRED TO AS AN INTERNATIONAL STANDARD UNTIL PUBLISHED AS SUCH.

IN ADDITION TO THEIR EVALUATION AS BEING ACCEPTABLE FOR INDUSTRIAL, TECHNOLOGICAL, COMMERCIAL AND USER PURPOSES, DRAFT INTERNATIONAL STANDARDS MAY ON OCCASION HAVE TO BE CONSIDERED IN THE LIGHT OF THEIR POTENTIAL TO BECOME STANDARDS TO WHICH REFERENCE MAY BE MADE IN NATIONAL REGULATIONS.

RECIPIENTS OF THIS DRAFT ARE INVITED TO SUBMIT, WITH THEIR COMMENTS, NOTIFICATION OF ANY RELEVANT PATENT RIGHTS OF WHICH THEY ARE AWARE AND TO PROVIDE SUPPORTING DOCUMENTATION.

ISO/CEN PARALLEL PROCESSING



Reference number
ISO/DIS 179-1:2022(E)

© ISO 2022

**iTeh STANDARD
PREVIEW
(standards.iteh.ai)**

[oSIST prEN ISO 179-1:2022](https://standards.iteh.ai/catalog/standards/sist/ebe0ddd1-2c4b-4937-9322-d333fef09495/osist-pren-iso-179-1-2022)
<https://standards.iteh.ai/catalog/standards/sist/ebe0ddd1-2c4b-4937-9322-d333fef09495/osist-pren-iso-179-1-2022>



COPYRIGHT PROTECTED DOCUMENT

© ISO 2022

All rights reserved. Unless otherwise specified, or required in the context of its implementation, no part of this publication may be reproduced or utilized otherwise in any form or by any means, electronic or mechanical, including photocopying, or posting on the internet or an intranet, without prior written permission. Permission can be requested from either ISO at the address below or ISO's member body in the country of the requester.

ISO copyright office
CP 401 • Ch. de Blandonnet 8
CH-1214 Vernier, Geneva
Phone: +41 22 749 01 11
Email: copyright@iso.org
Website: www.iso.org

Published in Switzerland

Contents

Page

Foreword	iv
1 Scope	1
2 Normative references	2
3 Terms and definitions	2
4 Principle	3
5 Apparatus	3
5.1 Test machine.....	3
5.2 Micrometers and gauges.....	3
6 Test specimens	4
6.1 Preparation.....	4
6.1.1 Moulding and extrusion compounds.....	4
6.1.2 Sheets.....	4
6.1.3 Long-fibre-reinforced materials.....	4
6.1.4 Checking.....	8
6.1.5 Notching.....	8
6.2 Anisotropy.....	8
6.3 Shape and dimensions.....	9
6.3.1 Materials not exhibiting interlaminar shear fracture.....	9
6.3.2 Materials exhibiting interlaminar shear fracture (e.g. long-fibre-reinforced materials).....	10
6.4 Number of test specimens.....	10
6.5 Definition of span between specimen supports, L	11
6.6 Conditioning.....	12
7 Procedure	12
8 Calculation and expression of results	13
8.1 Unnotched specimens.....	13
8.2 Notched specimens.....	13
8.3 Statistical parameters.....	13
8.4 Significant figures.....	14
9 Precision	14
10 Test report	14
Annex A (informative) Additional methods for investigating the influence of surface effects	16
Annex B (informative) Precision data	18
Annex C (informative) Determining the notch tip radius using a CCD microscope	20
Bibliography	23

ISO/DIS 179-1:2022(E)

Foreword

ISO (the International Organization for Standardization) is a worldwide federation of national standards bodies (ISO member bodies). The work of preparing International Standards is normally carried out through ISO technical committees. Each member body interested in a subject for which a technical committee has been established has the right to be represented on that committee. International organizations, governmental and non-governmental, in liaison with ISO, also take part in the work. ISO collaborates closely with the International Electrotechnical Commission (IEC) on all matters of electrotechnical standardization.

The procedures used to develop this document and those intended for its further maintenance are described in the ISO/IEC Directives, Part 1. In particular, the different approval criteria needed for the different types of ISO documents should be noted. This document was drafted in accordance with the editorial rules of the ISO/IEC Directives, Part 2 (see www.iso.org/directives).

Attention is drawn to the possibility that some of the elements of this document may be the subject of patent rights. ISO shall not be held responsible for identifying any or all such patent rights. Details of any patent rights identified during the development of the document will be in the Introduction and/or on the ISO list of patent declarations received (see www.iso.org/patents).

Any trade name used in this document is information given for the convenience of users and does not constitute an endorsement.

For an explanation of the voluntary nature of standards, the meaning of ISO specific terms and expressions related to conformity assessment, as well as information about ISO's adherence to the World Trade Organization (WTO) principles in the Technical Barriers to Trade (TBT), see www.iso.org/iso/foreword.html.

This document was prepared by Technical Committee ISO/TC 61, *Plastics*, Subcommittee SC 2, *Mechanical behavior*.

This third edition cancels and replaces the second edition (ISO 179-1:2010), which has been technically revised.

The main changes are as follows:

- results of a round robin for unnotched specimens (see [Annex B](#)) have been added;
- reference to standard ISO 16012 (see [Clause 2](#) and [subclause 5.2](#)) has been added;
- improvements of the micrometers and gauges subclause (see [5.2](#)) have been addressed;
- symbols used in [Equations \(1\)](#) and [\(2\)](#) have been reviewed and updated.

A list of all parts in the ISO 179 series can be found on the ISO website.

Any feedback or questions on this document should be directed to the user's national standards body. A complete listing of these bodies can be found at www.iso.org/members.html.

Plastics — Determination of Charpy impact properties —

Part 1: Non-instrumented impact test

1 Scope

1.1 This part of ISO 179 specifies a method for determining the Charpy impact strength of plastics under defined conditions. A number of different types of specimen and test configurations are defined. Different test parameters are specified according to the type of material, the type of test specimen and the type of notch.

1.2 The method can be used to investigate the behaviour of specified types of specimen under the impact conditions defined and for estimating the brittleness or toughness of specimens within the limitations inherent in the test conditions. It can also be used for the determination of comparative data from similar types of material.

1.3 The method has a greater range of applicability than that given in ISO 180^[1] and is more suitable for the testing of materials showing interlaminar shear fracture or of materials exhibiting surface effects due to environmental factors.

1.4 The method is suitable for use with the following range of materials:

- rigid thermoplastic moulding and extrusion materials (including filled and reinforced compounds in addition to unfilled types) and rigid thermoplastics sheets;
- rigid thermosetting moulding materials (including filled and reinforced compounds) and rigid thermosetting sheets (including laminates);
- fibre-reinforced thermosetting and thermoplastic composites incorporating unidirectional or multi-directional reinforcements (such as mats, woven fabrics, woven rovings, chopped strands, combination and hybrid reinforcements, rovings and milled fibres) or incorporating sheets made from pre-impregnated materials (prepregs), including filled and reinforced compounds;
- thermotropic liquid-crystal polymers.

1.5 Notched samples are not normally suitable for use with rigid cellular materials, long-fibre-reinforced composites or thermotropic liquid-crystal polymers. In these cases, unnotched samples may be used.

1.6 The method is suited to the use of specimens moulded to the chosen dimensions, machined from the central portion of a standard multipurpose test specimen (see ISO 3167) or machined from finished or semifinished products such as mouldings, laminates and extruded or cast sheet.

1.7 The method specifies preferred dimensions for the test specimen. Tests which are carried out on specimens of different dimensions or with different notches, or specimens which are prepared under different conditions, might produce results which are not comparable. Other factors, such as the energy capacity of the apparatus, the impact velocity and the conditioning of the specimens can also influence the results. Consequently, when comparative data are required, these factors must be carefully controlled and recorded.

ISO/DIS 179-1:2022(E)

1.8 The method should not be used as a source of data for design calculations. Information on the typical behaviour of a material can be obtained, however, by testing at different temperatures, by varying the notch radius and/or the specimen thickness and by testing specimens prepared under different conditions.

2 Normative references

The following documents are referred to in the text in such a way that some or all of their content constitutes requirements of this document. For dated references, only the edition cited applies. For undated references, the latest edition of the referenced document (including any amendments) applies.

ISO 291, *Plastics — Standard atmospheres for conditioning and testing*

ISO 293, *Plastics — Compression moulding of test specimens of thermoplastic materials*

ISO 294-1, *Plastics — Injection moulding of test specimens of thermoplastic materials — Part 1: General principles, and moulding of multipurpose and bar test specimens*

ISO 294-3, *Plastics — Injection moulding of test specimens of thermoplastic materials — Part 3: Small plates*

ISO 295, *Plastics — Compression moulding of test specimens of thermosetting materials*

ISO 1268-11, *Fibre-reinforced plastics — Methods of producing test plates — Part 11: Injection moulding of BMC and other long-fibre moulding compounds — Small plates*

ISO 2602, *Statistical interpretation of test results — Estimation of the mean — Confidence interval*

ISO 2818, *Plastics — Preparation of test specimens by machining*

ISO 3167, *Plastics — Multipurpose test specimens*

ISO 10724-1, *Plastics — Injection moulding of test specimens of thermosetting powder moulding compounds (PMCs) — Part 1: General principles and moulding of multipurpose test specimens*

ISO 13802, *Plastics — Verification of pendulum impact-testing machines — Charpy, Izod and tensile impact-testing*

ISO 16012, *Plastics — Determination of linear dimensions of test specimens*

3 Terms and definitions

For the purposes of this document, the following terms and definitions apply.

ISO and IEC maintain terminology databases for use in standardization at the following addresses:

— ISO Online browsing platform: available at <https://www.iso.org/obp>

— IEC Electropedia: available at <https://www.electropedia.org/>

3.1 Charpy unnotched impact strength

a_{cU}
impact energy absorbed in breaking an unnotched specimen, referred to the original cross-sectional area of the specimen

Note 1 to entry: It is expressed in kilojoules per square metre (kJ/m²).

3.2**Charpy notched impact strength** a_{cN}

impact energy absorbed in breaking a notched specimen, referred to the original cross-sectional area of the specimen at the notch, where N = A, B or C, depending on the notch type (see [6.3.1.1.2](#))

Note 1 to entry: It is expressed in kilojoules per square metre (kJ/m²).

3.3**edgewise impact**

e

direction of blow parallel to the dimension b , with impact on the narrow longitudinal surface $h \times l$ of the specimen (see [Figure 1](#), left, and [Figures 2](#) and [4](#))

3.4**flatwise impact**

f

direction of blow parallel to the dimension h , with impact on the broad longitudinal surface $b \times l$ of the specimen (see [Figure 1](#), right, and [Figures 3](#) and [4](#))

3.5**normal impact**

n

<laminar-reinforced plastics> impact with the direction of blow normal to the plane of reinforcement (see [Figure 4](#))

3.6**parallel impact**

p

<laminar-reinforced plastics> impact with the direction of blow parallel to the plane of reinforcement (see [Figure 4](#))

4 Principle

<https://standards.iteh.ai/catalog/standards/sist/ebe0ddd1-2c4b-4937-9322-d333fef09495/osist-pren-iso-179-1-2022>

The test specimen, supported near its ends as a horizontal beam, is impacted by a single blow of a striker, with the line of impact midway between the supports, and bent at a high, nominally constant, velocity.

In the case of edgewise impact with notched specimens, the line of impact is directly opposite the single notch (see [Figure 1](#), left, and [Figure 2](#)).

5 Apparatus**5.1 Test machine**

The principles, characteristics and verification of suitable test machines are detailed in ISO 13802.

ISO 13802 describes partial verification and full verification. In the case of full verification, some items are difficult to verify when the apparatus is assembled. Such verifications are assumed to be incumbent on the manufacturer.

5.2 Micrometers and gauges

Micrometers and gauges shall allow to determine the relevant dimensions of the test specimens with an uncertainty not larger than 0,02 mm. For the determination of the dimension b_N of notched test specimens measuring tips appropriate for the contour of the notch must be used. For general information on the determination of test specimen dimensions, see ISO 16012.

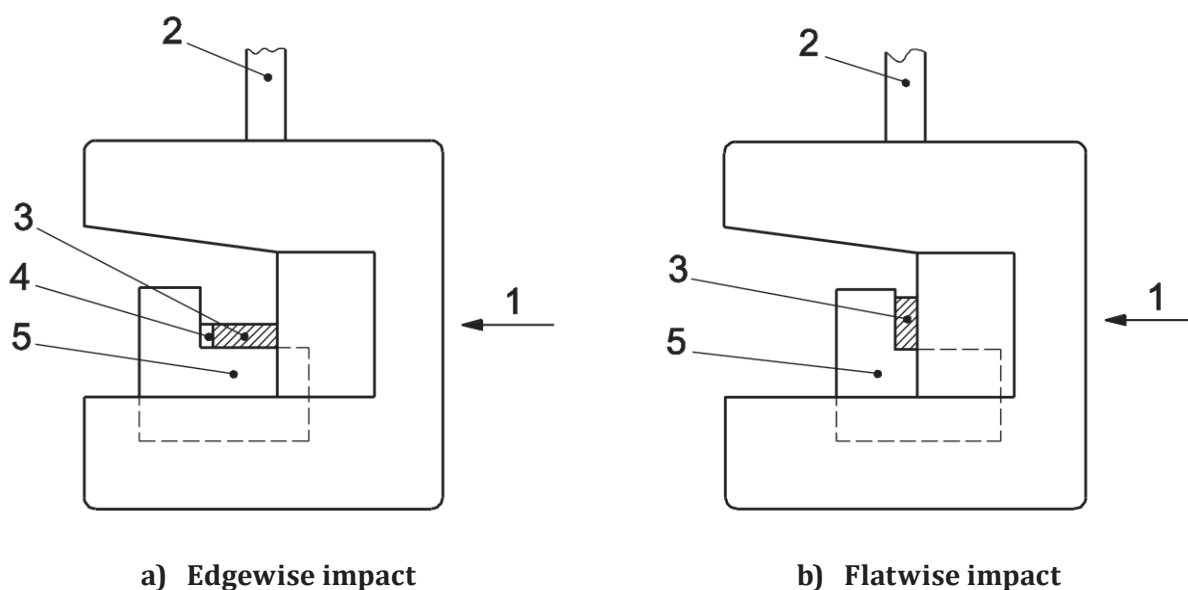
**Key**

- 1 direction of blow
- 2 rod of pendulum
- 3 test specimen
- 4 notch
- 5 support

**iTeh STANDARD
PREVIEW
(standards.iteh.ai)**

Figure 1 — Striking edge and support blocks for type 1 test specimen at moment of impact

[oSIST prEN ISO 179-1:2022](https://standards.iteh.ai/catalog/standards/sist/ebe0ddd1-2c4b-4937-9322-d333fef09495/osist-pren-iso-179-1-2022)

6 Test specimens

<https://standards.iteh.ai/catalog/standards/sist/ebe0ddd1-2c4b-4937-9322-d333fef09495/osist-pren-iso-179-1-2022>

6.1 Preparation

6.1.1 Moulding and extrusion compounds

Specimens shall be prepared in accordance with the relevant material specification. The specimens shall be either directly compression moulded in accordance with ISO 293 or ISO 295 or injection moulded from the material in accordance with ISO 294-1, ISO 294-3 or ISO 10724-1, as appropriate, or machined in accordance with ISO 2818 from sheet that has been compression or injection moulded from the compound. Type 1 specimens may be cut from multipurpose test specimens complying with ISO 3167, type A.

6.1.2 Sheets

Specimens shall be machined from sheets in accordance with ISO 2818.

6.1.3 Long-fibre-reinforced materials

A panel shall be prepared in accordance with ISO 1268-11 or another specified or agreed upon preparation procedure. Specimens shall be machined in accordance with ISO 2818.

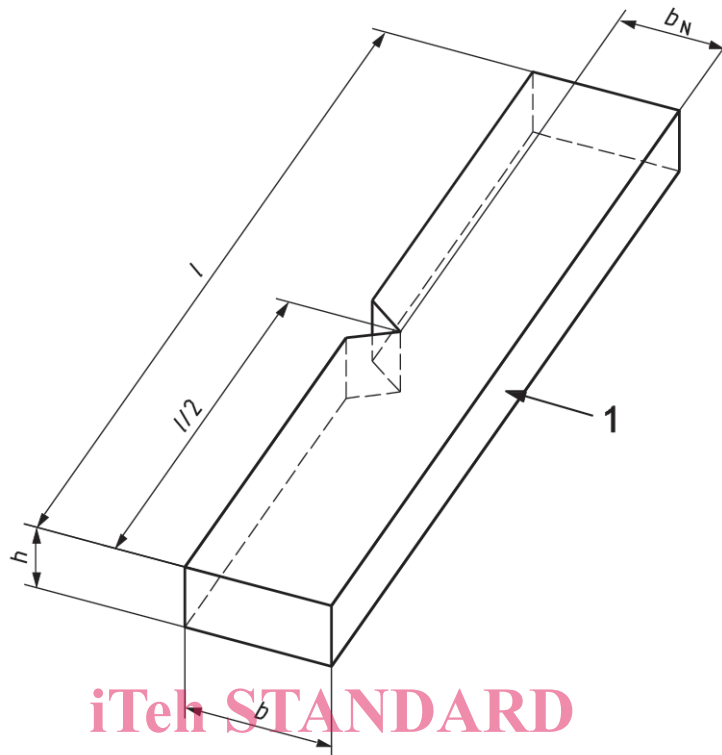
**Key**

1 direction of blow

**iTeh STANDARD
PREVIEW
(standards.iteh.ai)**

Figure 2 — Charpy edgewise impact (e) with single-notched specimen

[oSIST prEN ISO 179-1:2022](https://standards.iteh.ai/catalog/standards/sist/ebe0ddd1-2c4b-4937-9322-d333fef09495/osist-pren-iso-179-1-2022)

<https://standards.iteh.ai/catalog/standards/sist/ebe0ddd1-2c4b-4937-9322-d333fef09495/osist-pren-iso-179-1-2022>