



Designation: ~~D6667-04 (Reapproved 2010)~~ Designation: D6667 – 10

# Standard Test Method for Determination of Total Volatile Sulfur in Gaseous Hydrocarbons and Liquefied Petroleum Gases by Ultraviolet Fluorescence<sup>1</sup>

This standard is issued under the fixed designation D6667; the number immediately following the designation indicates the year of original adoption or, in the case of revision, the year of last revision. A number in parentheses indicates the year of last reapproval. A superscript epsilon ( $\epsilon$ ) indicates an editorial change since the last revision or reapproval.

## 1. Scope\*

1.1 This test method covers the determination of total volatile sulfur in gaseous hydrocarbons and liquefied petroleum (LP) gases. It is applicable to analysis of natural, processed, and final product materials containing sulfur in the range of 1 to 100 mg/kg (Note 1).

NOTE 1—An estimate of pooled limit of quantification (PLOQ), information regarding sample stability and other general information derived from the inter-laboratory study on precision can be referenced in the ASTM research report.<sup>2</sup>

1.2 This test method may not detect sulfur compounds that do not vaporize under the conditions of the test.

1.3 This test method is applicable for total volatile sulfur determination in LP gases containing less than 0.35 % (mass/mass) halogen(s).

1.4 The values stated in SI units are to be regarded as standard.

1.5 *This standard does not purport to address all of the safety concerns, if any, associated with its use. It is the responsibility of the user of this standard to establish appropriate safety and health practices and determine the applicability of regulatory limitations prior to use.* See 3.1 and Sections 6 and 7 for specific warning statements.

## 2. Referenced Documents

2.1 *ASTM Standards:*<sup>3</sup>

D1070 Test Methods for Relative Density of Gaseous Fuels

D1265 Practice for Sampling Liquefied Petroleum (LP) Gases, Manual Method

D3700 Practice for Obtaining LPG Samples Using a Floating Piston Cylinder

D5287 Practice for Automatic Sampling of Gaseous Fuels

D6299 Practice for Applying Statistical Quality Assurance and Control Charting Techniques to Evaluate Analytical Measurement System Performance

F307 Practice for Sampling Pressurized Gas for Gas Analysis

2.2 *Gas Processor Association (GPA) Standards:*<sup>4</sup>

GPA 2166 Obtaining Natural Gas Samples for Analysis by Gas Chromatography

GPA 2174 Obtaining Liquid Hydrocarbon Samples for Analysis by Gas Chromatography

## 3. Summary of Test Method

3.1 A heated sample valve is used to inject gaseous samples. Liquefied petroleum gas (LPG) samples are injected by a sample valve connected to a heated expansion chamber. The gaseous sample then enters a high temperature combustion tube where sulfur is oxidized to sulfur dioxide ( $\text{SO}_2$ ) in an oxygen rich atmosphere. Water produced during the sample combustion is removed and the sample combustion gases are next exposed to ultraviolet (UV) light. The  $\text{SO}_2$  absorbs the energy from the UV light and is converted to an excited sulfur dioxide ( $\text{SO}_2^*$ ). Fluorescence emitted from the excited  $\text{SO}_2^*$  as it returns to a stable state  $\text{SO}_2$  is detected by a photomultiplier tube, the resulting signal is a measure of the sulfur contained in the sample. (**Warning**—Exposure to excessive quantities of ultraviolet light is injurious to health. The operator shall avoid exposing their person, especially their

<sup>1</sup> This test method is under the jurisdiction of ASTM Committee D02 on Petroleum Products and Lubricants and is the direct responsibility of Subcommittee D02.03 on Elemental Analysis.

Current edition approved May/Oct. 1, 2010. Published May/November 2010. Originally approved in 2001. Last previous edition approved in 2004/2010 as D6667-04(2010). DOI: 10.1520/D6667-10.

<sup>2</sup> Supporting data have been filed at ASTM International Headquarters and may be obtained by requesting Research Report RR:D02-1506.

<sup>3</sup> For referenced ASTM standards, visit the ASTM website, www.astm.org, or contact ASTM Customer Service at service@astm.org. For *Annual Book of ASTM Standards* volume information, refer to the standard's Document Summary page on the ASTM website.

<sup>4</sup> Available from Gas Processors Association (GPA), 6526 E. 60th St., Tulsa, OK 74145.

\*A Summary of Changes section appears at the end of this standard.

eyes, not only to direct UV light but also to secondary or scattered radiation that is present.)

#### 4. Significance and Use

4.1 The sulfur content of LPG, used for fuel purposes, contributes to SO<sub>x</sub> emissions and can lead to corrosion in engine and exhaust systems. Some process catalysts used in petroleum and chemical refining can be poisoned by sulfur bearing materials in the feed stocks. This test method can be used to determine sulfur in process feeds, to measure sulfur in finished products, and can also be used for compliance determinations when acceptable to a regulatory authority.

#### 5. Apparatus

5.1 *Furnace*—An electric furnace held at a temperature ( $1075 \pm 25^\circ\text{C}$ ) sufficient to pyrolyze the entire sample and oxidize sulfur to SO<sub>2</sub>.

5.2 *Combustion Tube*—A quartz combustion tube constructed to allow the direct injection of the sample into the heated oxidation zone of the furnace. The combustion tube shall have side arms for the introduction of oxygen and carrier gas. The oxidation section shall be large enough (see Fig. 1) to ensure complete combustion of the sample (see 11.3). Fig. 1 depicts a typical combustion tube. Other configurations are acceptable when precision is not degraded.

5.3 *Flow Control*—The apparatus shall be equipped with flow controllers capable of maintaining a constant supply of oxygen and carrier gas at the specified rates.

5.4 *Drier Tube*—The apparatus shall be equipped with a mechanism for the removal of water vapor formed during sample combustion. This can be accomplished with a membrane drying tube, or a permeation dryer that utilizes a selective capillary action for water removal.

5.5 *UV Fluorescence Detector*—A quantitative detector capable of measuring light emitted from the fluorescence of sulfur dioxide by UV light.

5.6 *Sample Inlet System*—The system provides a heated gas-sampling valve, or a LP gas-sampling valve, or both, with a heated expansion chamber, connected to the inlet of the oxidation area, Fig. 2. The system is swept by an inert carrier gas and shall be capable of allowing the quantitative delivery of the material to be analyzed into the oxidation zone at a controlled and repeatable rate of approximately 30 mL/min. Fig. 3 provides an example.

5.7 *Strip Chart Recorder*, equivalent electronic data logger, integrator or, recorder (optional).

#### 6. Reagents

6.1 *Purity of Reagents*—Reagent grade chemicals shall be used in tests. Unless otherwise indicated, it is intended that all reagents shall conform to the specifications of the Committee on Analytical Reagents of the American Chemical Society,<sup>5</sup> where

<sup>5</sup> *Reagent Chemicals, American Chemical Society Specifications*, American Chemical Society, Washington, DC. For suggestions on the testing of reagents not listed by the American Chemical Society, see *Analar Standards for Laboratory Chemicals*, BDH Ltd., Poole, Dorset, U.K., and the *United States Pharmacopeia and National Formulary*, U.S. Pharmacopeial Convention, Inc. (USPC), Rockville, MD.

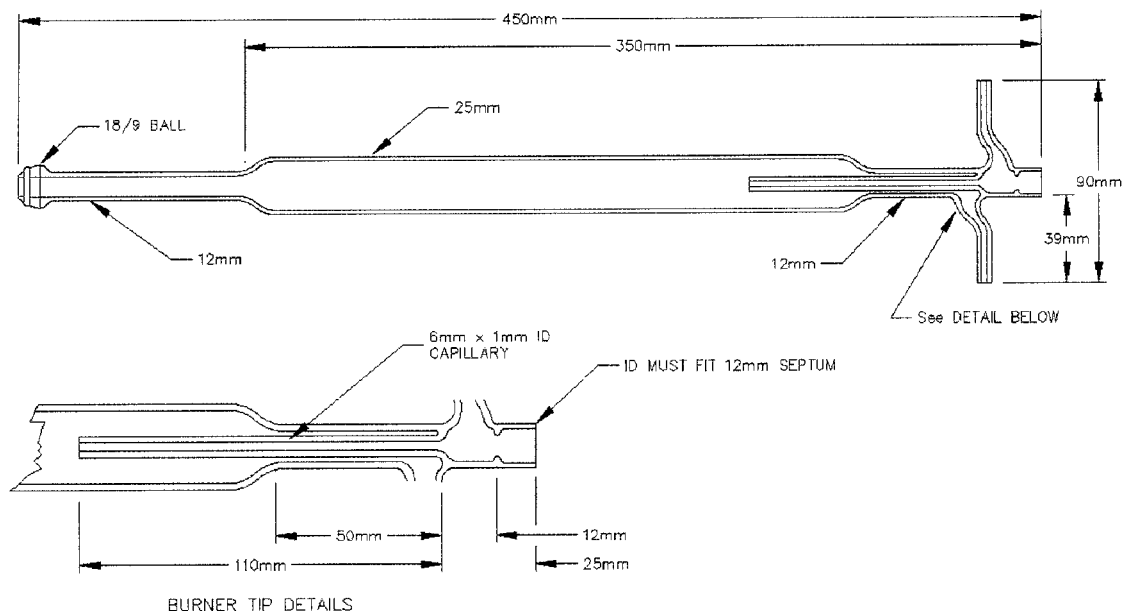

FIG. 1 Example of a Typical Direct Inject Quartz Pyrolysis Tube

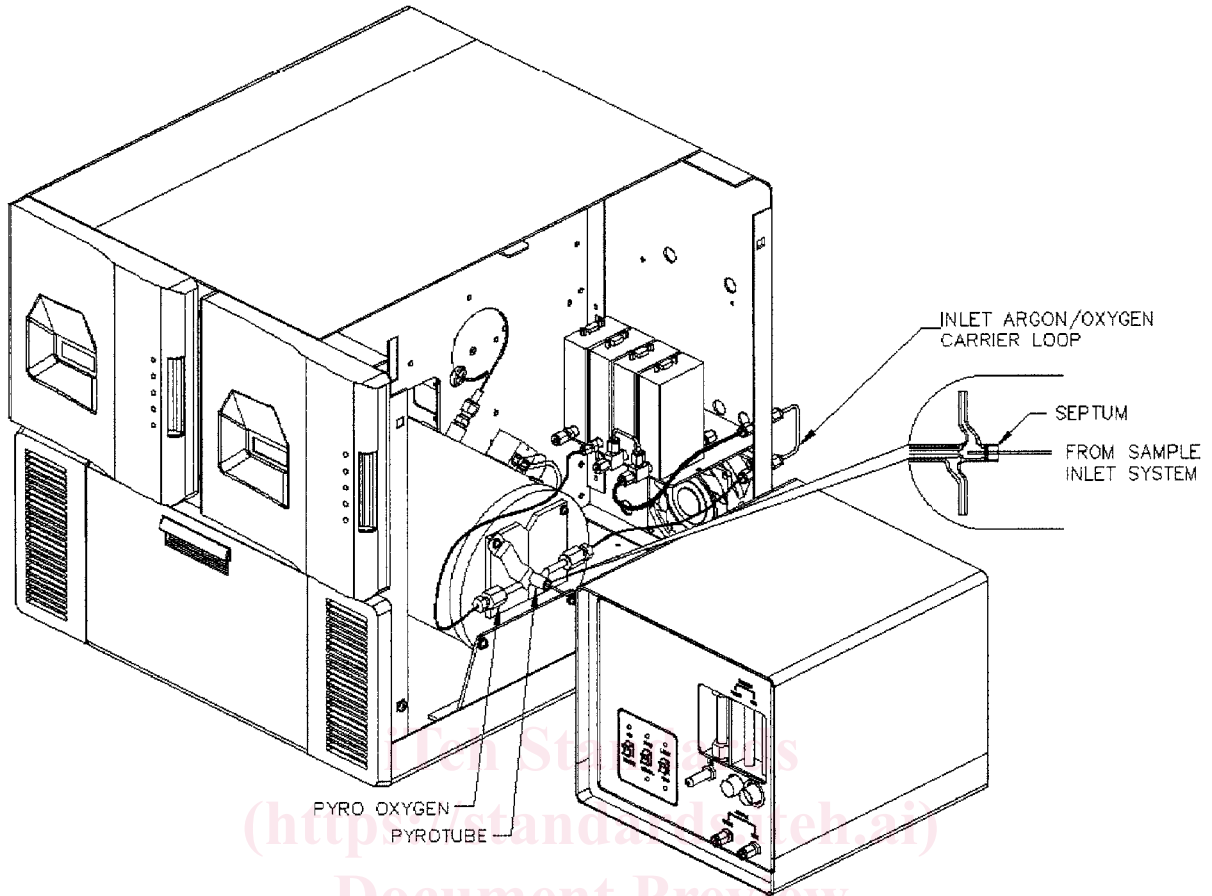

FIG. 2 Example of Orientation of Total Sulfur Analyzer and Gas or Liquid Sampling Valve

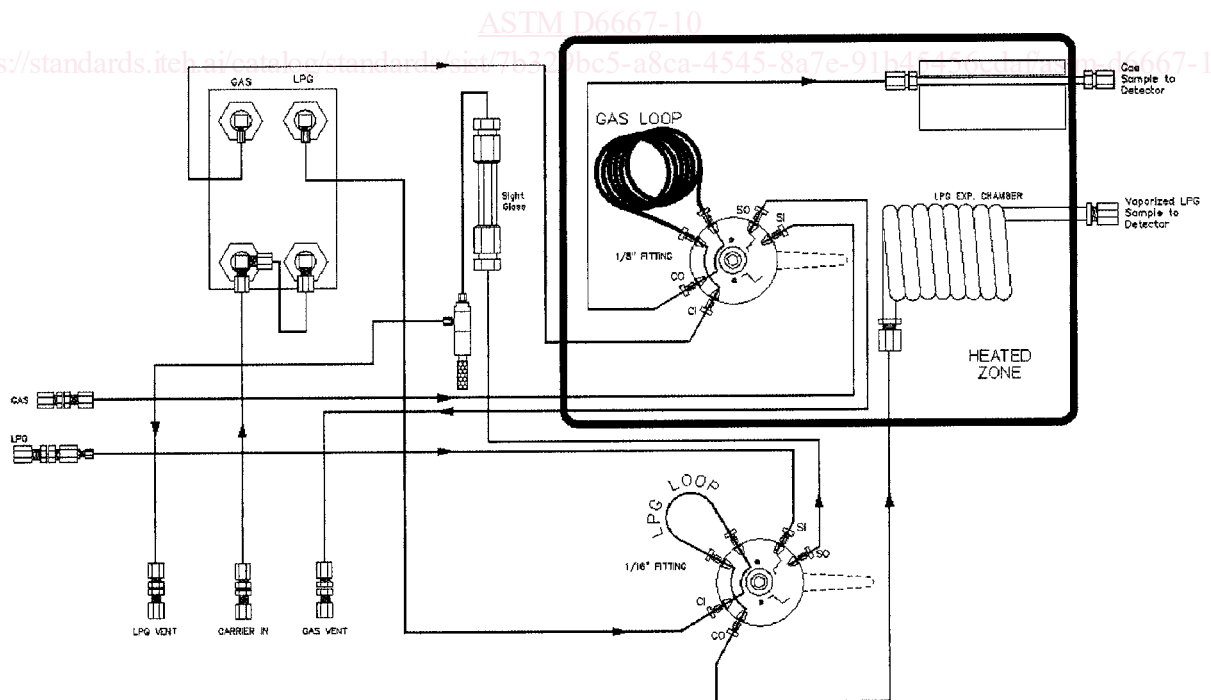

FIG. 3 Sample Inlet System Flow Path

such specifications are available. Other grades may be used, provided it is first ascertained that the reagent is of sufficiently high purity to permit its use without lessening the accuracy of the determination.

6.2 *Inert Gas*—Argon or helium only, high purity grade (that is, chromatography or zero grade), 99.998 % min purity, moisture 5 mg/kg max. (**Warning** —Argon or helium may be a compressed gas under high pressure (7.1)).

6.3 *Oxygen*—High purity (that is chromatography or zero grade), 99.75 % min purity, moisture 5 mg/kg max, dried over molecular sieves. (**Warning**—Oxygen vigorously accelerates combustion and may be compressed gas under high pressure (7.1)).

6.4 *Calibration Standards*—Certified calibration standards from commercial sources or calibration gases prepared using certified permeation tube devices are required. Table 1 lists the sulfur source material and diluent matrices used during the inter-laboratory study (Notes 2 and 3).

NOTE 2—Other sulfur sources and diluent materials may be used if precision and accuracy are not degraded.

NOTE 3—Calibration standards are typically re-mixed and re-certified on a regular basis depending upon frequency of use and age. These calibration standards may have a useful life of about 6 to 12 months.

6.5 *Quality Control (QC) Samples*, preferably are portions of one or more gas or LP gas materials that are stable and representative of the samples of interest.

## 7. Hazards

7.1 High temperature, flammable hydrocarbons, and gases under high pressures occur in the test method. Use materials that are rated for containing these pressurized hydrocarbons in all sample containers and sample transfer apparatus. Exercise extra care when using flammable materials near the oxidative furnace.

## 8. Sampling

8.1 Obtain a sample in accordance with Practices F307, D1265, D3700, D5287, or GPA 2174 or GPA 2166. Analyze samples as soon as possible after taking from bulk supplies to prevent loss of sulfur or contamination due to exposure or contact with sample containers.

8.2 If the sample is not used immediately, then thoroughly mix it in its container prior to taking a test specimen. The use of segregated or specially treated sample containers can help reduce sample cross-contamination and improve sample stability.

## 9. Preparation of Apparatus

9.1 Assemble and check the apparatus for leaks according to manufacturer’s instructions.

9.2 Typical apparatus adjustments and conditions are listed in Table 2.

9.3 Adjust instrument sensitivity and baseline stability and perform instrument-blanking procedures following manufacturer’s guidelines.

## 10. Calibration and Standardization

10.1 Consult Table 3 and select a calibration range based on the anticipated sulfur concentrations present in samples to be analyzed, preferably using a sulfur compound and a diluent type representative of the samples to be analyzed (Note 4). Table 3 is representative of typical ranges, but narrower ranges than those indicated may be used if desired. However, the method precision using narrower ranges than those indicated has not been determined. Ensure the standards used for calibration bracket the concentrations of the samples being analyzed.

NOTE 4—The number of standards used per curve may vary.

10.2 With the sample valve in the load position, connect the pressurized sample container to the sample valve of the sample inlet system.

10.3 Obtain a quantitative measurement of the injected material by filling the sample loop of the sample valve system for the matrix being analyzed (see Table 2) (Notes 5 and 6).

NOTE 5—Injection of a constant or similar sample size for all materials analyzed in a selected operating range promotes consistent combustion conditions and may simplify result calculations.

NOTE 6—An automatic sample transfer and injection device may be used.

10.3.1 Flush the sample loop with sufficient calibrant to assure that the material to be injected is representative.

10.3.2 For LPG samples, if bubbles are present in the viewable portion of the liquid column, flush the sample loop to introduce a new liquid-full sample portion.

**TABLE 1 Typical Standard Materials**

Sulfur Source	Diluent
Dimethyl sulfide	n, butane iso-butane propylene propane