



Designation: ~~E966-04~~ Designation: E966 - 10

# Standard Guide for Field Measurements of Airborne Sound Insulation Attenuation of Building Facades and Facade Elements<sup>1</sup>

This standard is issued under the fixed designation E966; the number immediately following the designation indicates the year of original adoption or, in the case of revision, the year of last revision. A number in parentheses indicates the year of last reapproval. A superscript epsilon ( $\epsilon$ ) indicates an editorial change since the last revision or reapproval.

## INTRODUCTION

The sound transmission of a building facade or facade element as measured under field conditions is dependent not only on the physical characteristics of the facade, but also on the characteristics of the incident sound field used to make the measurement. This is also true for laboratory tests of panels using the two-room method described in Test Method

This guide provides methods to measure the sound isolation of a room from outdoor sound, and to evaluate the sound transmission or apparent sound transmission through a particular facade of the room or an element of that facade such as a window or door. Measurements from outdoors to indoors differ from measurements between two rooms. The outdoor sound field is not diffuse and the transmission of that sound through the structure is a function of the outdoor sound angle of incidence. The outdoor-indoor transmission loss values obtained with this guide are not expected to be the same as that obtained in laboratory or other tests between two rooms using diffuse incident sound. At this time, there are insufficient data available to specify a single, standard measurement procedure suitable for all field situations. For this reason, this guide provides alternative test procedures for the measurements of facade field level reduction and transmission loss.

This guide is part of a set of standards for evaluating the sound isolation of rooms and the sound insulating properties of building elements. Others in this set cover the airborne sound transmission loss of an isolated partition element in a controlled laboratory environment (Test Method E90; however, the incident sound field in these controlled tests is made uniformly diffuse. The same is approximately true for field measurements of noise reduction and transmission loss by Test Method ), the laboratory measurement of impact sound transmission through floors (Test Method E492), the measurement of airborne sound transmission in buildings (Test Method E336). Such uniformity is not possible for facade measurements in the field where each situation is unique, resulting in incident sound fields that may range all the way from free field produced by a point source to quasi-diffuse produced by a line source.

At this time, there are insufficient data available to specify a single, standard measurement procedure suitable for all field situations. For this reason, this guide provides a number of alternative test procedures for the measurements of facade field level reduction and transmission loss, the measurement of impact sound transmission in buildings (Test Method E1007), and the measurement of sound transmission through a common plenum between two rooms (Test Method E1414).

## 1. Scope

1.1 This guide covers field procedures for measuring the sound level reduction or sound transmission loss of an installed building facade or facade element in specified frequency bands. These values may be used separately to predict interior levels or combined into a single number such as by Classification E413 (with precautions) or Classification

1.1 This guide may be used to determine the outdoor-indoor noise reduction (OINR), which is the difference in sound pressure level between the free-field level outdoors in the absence of the structure and the resulting sound pressure level in a room. Either

<sup>1</sup> This guide is under the jurisdiction of ASTM Committee E33 on Building and Environmental Acoustics and is the direct responsibility of Subcommittee E33.03 on Sound Transmission.

Current edition approved April-Sept. 1, 2004-2010. Published April-2004-December 2010. Originally approved in 1984. Last previous edition approved in 2002-2004 as E966 - 024. DOI: 10.1520/E0966-104.

a loudspeaker or existing traffic noise or aircraft noise can be used as the source. The outdoor sound field geometry must be described and calculations must account for the way the outdoor level is measured. These results are used with Classification E1332 to estimate the sound-insulating properties of the test element, FOITC, in the field. The results are applicable to installations similar to that tested when exposed to an outdoor sound field similar to that used during the measurement.

1.1.1 The facade element may be the exterior wall of a room in the building, or a portion of that wall such as a door or window, when the remainder of that wall has substantially greater sound insulation than the portion under test.

1.2 To cope with the variety of outdoor test geometry that may be encountered, several testing techniques are presented. These techniques and their general applicability are summarized in to calculate the single number rating outdoor-indoor noise isolation class, OINIC. Both OINR and OINIC can vary with outdoor sound incidence angle.

1.2 Under controlled circumstances where a single façade is exposed to the outdoor sound, or a façade element such as a door or window has much lower transmission loss than the rest of the façade, an outdoor-indoor transmission loss, OITL( $\theta$ ), or apparent outdoor-indoor transmission loss, AOITL( $\theta$ ), may be measured using a loudspeaker source. These results are a function of the angle of incidence of the sound field. By measuring with sound incident at many angles, an approximation to the diffuse field transmission loss as measured between two rooms can be obtained. The results may be used to predict interior sound levels in installations similar to that tested when exposed to an outdoor sound field similar to that used during the measurement. The single number ratings of apparent outdoor-indoor transmission class, AOITC( $\theta$ ), using AOITL( $\theta$ ) and field outdoor-indoor transmission class, FOITC( $\theta$ ), using OITL( $\theta$ ) may be calculated using Classification E1332. These ratings also may be calculated with the data obtained from receiving room sound pressure measurements performed at several incidence angles as discussed in 8.6.

1.3 To cope with the variety of outdoor incident sound field geometries that are encountered in the field, six testing techniques are presented. These techniques and their general applicability are summarized in Table 1 and Figs. 1-6:

1.3 This guide may be used to determine the outdoor-indoor level reduction (OILR), which is the difference in sound pressure between a specified outdoor sound field and the resulting sound pressure level in the room abutting the test facade or facade element. The outdoor sound field and its measurement must be thoroughly described. The resulting level reduction or transmission loss value will depend on the outdoor field geometry and the point at which it is measured or represented.

1.4 The values stated in SI units are to be regarded as standard. The values given in parentheses are provided for information only. The room, façade, or façade element declared to be under test is referred to as the specimen.

1.4 The values stated in SI units are to be regarded as standard. No other units of measurement are included in this standard.

1.5 This standard does not purport to address the safety concerns, if any, associated with its use. It is the responsibility of the user of this standard to establish appropriate safety and health practices and determine the applicability of regulatory limitations prior to use.

1.6 The text of this standard references notes and footnotes which provide explanatory material. These notes and footnotes (excluding those in tables and figures) shall not be considered as requirements of the standard.

## 2. Referenced Documents

- 2.1 *ASTM Standards*:<sup>2</sup>
- C423 Test Method for Sound Absorption and Sound Absorption Coefficients by the Reverberation Room Method
  - C634 Terminology Relating to Building and Environmental Acoustics
  - E90 Test Method for Laboratory Measurement of Airborne Sound Transmission Loss of Building Partitions and Elements
  - E336 Test Method for Measurement of Airborne Sound Attenuation between Rooms in Buildings
  - E413 Classification for Rating Sound Insulation
  - 492 Test Method for Laboratory Measurement of Impact Sound Transmission Through Floor-Ceiling Assemblies Using the Tapping Machine
  - E1007 Test Method for Field Measurement of Tapping Machine Impact Sound Transmission Through Floor-Ceiling Assemblies and Associated Support Structures
  - E1332 Classification for Rating Outdoor-Indoor Sound Attenuation
  - E1414 Test Method for Airborne Sound Attenuation Between Rooms Sharing a Common Ceiling Plenum
  - E2235 Test Method for Determination of Decay Rates for Use in Sound Insulation Test Methods
- 2.2 *ANSI Standards*:<sup>3</sup>
- S1.4 Specification for Sound Level Meters
  - S1.11 Specification for Octave-Band and Fractional-Octave Analog and Digital Filter Sets
  - S1.31 Precision Methods for the Determination of Sound Power Levels of Broadband Sources in Reverberation Rooms
  - S1.40 Specifications and Verification Procedures for Sound Calibrators
  - S1.43 Specifications for Integrating -Averaging Sound Level Meters
- 2.3 *IEC Standards*:<sup>3</sup>
- IEC Publication 651—Sound Level Meters
  - IEC 61672 Electroacoustics - Sound Level Meters

<sup>2</sup> For referenced ASTM standards, visit the ASTM website, [www.astm.org](http://www.astm.org), or contact ASTM Customer Service at [service@astm.org](mailto:service@astm.org). For *Annual Book of ASTM Standards* volume information, refer to the standard's Document Summary page on the ASTM website.

<sup>3</sup> Available from the American National Standards Institute, 25 W. 43rd St., 4th Floor, New York, NY, 10036.

<sup>3</sup> Available from American National Standards Institute (ANSI), 25 W. 43rd St., 4th Floor, New York, NY 10036, <http://www.ansi.org>.

TABLE 1 Application Guide to Measurement of Outdoor-Indoor Level Reduction (ONILR) of Facade Elements<sup>A</sup>

Outdoor Signal Source Loudspeaker Required for OITL or AOTL	Outdoor Microphone Position	Measurement Section, Figure, Calculation Reference See Equation	Applications Remarks
Calibrated loudspeaker at $\theta = 45^\circ$ from test element	Incident sound pressure inferred from separate calibration of source	8.3.1, Fig. 1; Eq 4	Use when traffic noise is not available or when outdoor measurement at or near facade is not possible.
Calibrated loudspeaker	Incident sound pressure inferred from separate calibration of source	8.3.1, Fig. 1; Eq 3	Use when outdoor measurement at or near specimen is not possible.
Loudspeaker at $\theta = 45^\circ$ from test element	Several locations averaged about 1.2 m to 2.4 m from the facade element	8.3.2, Fig. 2; Eq 5	Use when calibrated source or flush measurement is not possible.
Loudspeaker	Several locations averaged about 1.2 m to 2.4 m from the facade element	8.3.2, Fig. 2; Eq 4	Use when calibrated source or flush measurement is not possible.
Loudspeaker at $\theta = 45^\circ$ from test element	Several locations less than 17 mm from facade element	8.3.3, Fig. 3; Eq 6	Use when traffic noise is not available and when loudspeaker cannot be calibrated.
Loudspeaker	Several locations less than 17 mm from specimen	8.3.3, Fig. 3; Eq 5	Use when the loudspeaker cannot be calibrated.
Traffic or equivalent	Simultaneous measurement remote from the facade	9.5.1, Fig. 4; Eq 8	Source far from facade (that is, consistent traffic/aircraft over flights).
Traffic, aircraft, or similar line source	Simultaneous measurement remote from the specimen	9.3.1, Fig. 4; Eq 7	Use when it is possible to measure source in free field at same distance as specimen.
Traffic or equivalent, moving parallel with facade	Simultaneous measurement 2 m (79 in.) from facade	9.5.2, Fig. 5; Eq 9	Suitable when facade faces traffic. Smooth or rough facades. OILR and OITL down to 80 Hz.
Traffic, aircraft, or similar line source	Simultaneous measurement 2 m from the specimen surface	9.3.2, Fig. 5; Eq 9	Use when remote measurement or flush measurement is not possible.
Traffic or equivalent, moving parallel with facade	Simultaneous measurement less than 17 mm from facade surface	9.5.3, Fig. 6; Eq 10	Smooth or rough facade element test (for example, window, wall air conditioner, etc.); OILR & OITL to 5000 Hz.
Traffic, aircraft, or similar line source	Simultaneous measurement with entire microphone diaphragm within 17 mm of the specimen	9.3.3, Fig. 6; Eq 10	Use when remote measurement is not possible.

<sup>A</sup>See 5.1, 8.3 and 9.2.

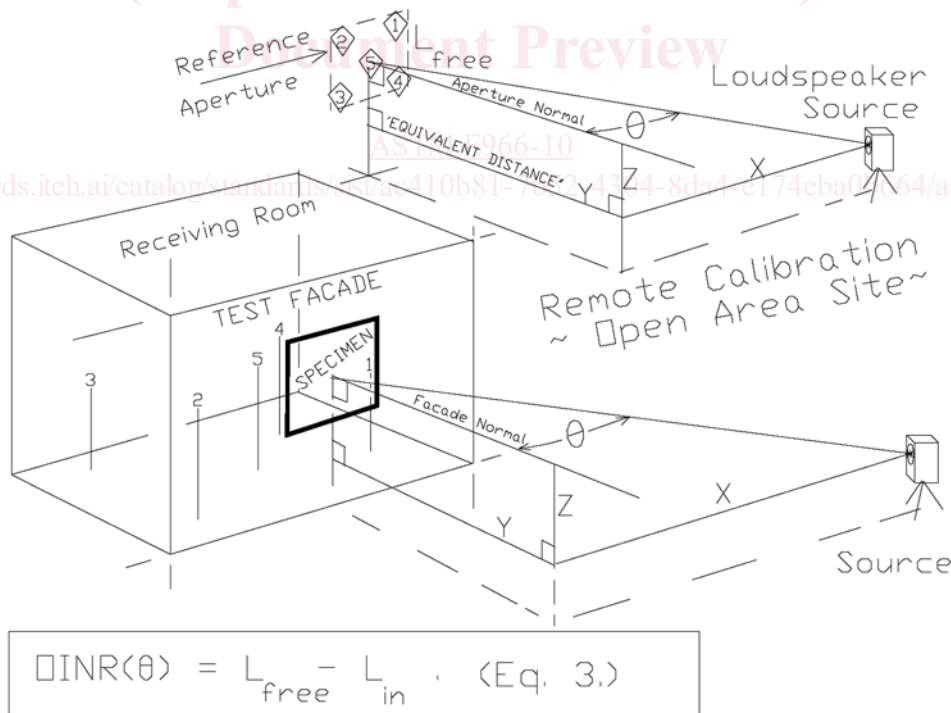

FIG. 1 Geometry—Calibrated Source Method

IEC Publication 804 Integrating-Averaging Sound Level Meters IEC 60942 Electroacoustics - Sound Calibrators

### 3. Terminology

3.1 Definitions—For acoustical terms used in this guide, see Terminology C634.

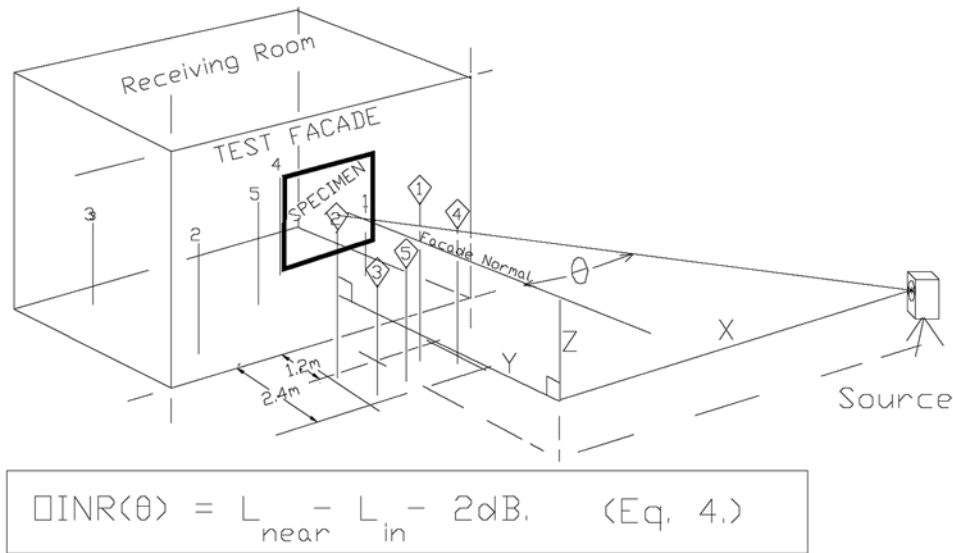

FIG. 2 Geometry—Nearby Average Method

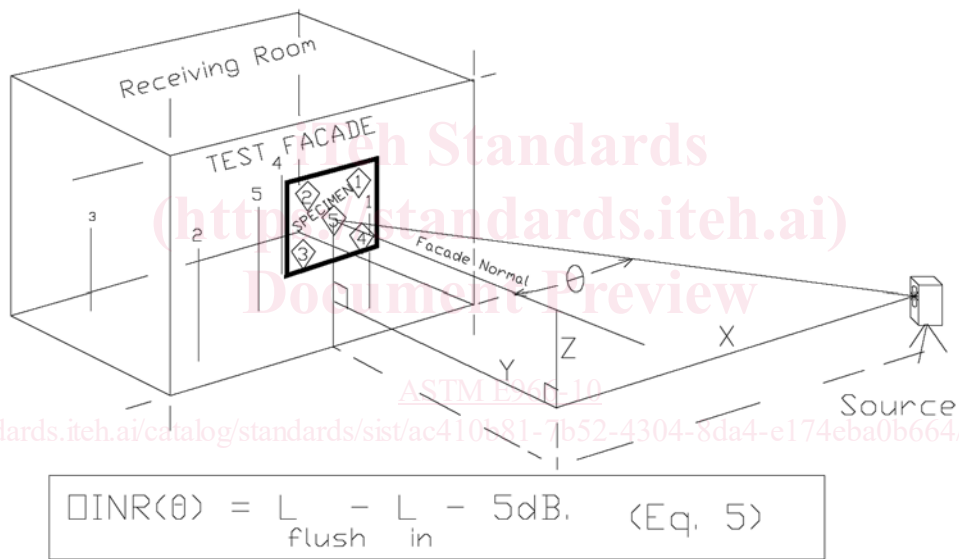

FIG. 3 Geometry—Flush Method

3.2 Definitions of Terms Specific to This Standard:

3.2.1 *apparent outdoor-indoor transmission loss, apparent OITL* ( $\theta$ )—the value of outdoor-indoor transmission loss obtained on a test facade element as installed, without flanking tests to identify or eliminate extraneous transmission paths; the apparent OITL is the lower limiting value of the outdoor-indoor transmission loss of the facade element.

3.2.2 *coincidence transmission*—transmission loss which is especially angular dependent (see 8.2.3.2):

3.2.3 *field outside-inside transmission class, FOITC*—the single number rating obtained by Classification E413 or E1332 with the OITL values:

3.2.4 *outdoor-indoor level reduction, OILR*—in a specified frequency band, the difference between the time-averaged exterior sound pressure and the space-time average sound pressure in a room of a building; apparent outdoor-indoor transmission class, apparent AOITL( $\theta$ ),  $n$ —of a building facade or facade element at a specified angle  $\theta$  or range of angles, a single-number rating calculated in accordance with Classification E1332 using measured values of apparent outdoor-indoor transmission loss.

3.2.2 *apparent outdoor-indoor transmission loss, AOITL*( $\theta$ ), (dB),  $n$ —of a building facade or facade element in a specified frequency band, for a source at a specified angle  $\theta$  or range of angles as measured from the normal to the center of the specimen surface, the value of outdoor-indoor transmission loss obtained on a test facade element as installed, without flanking tests to identify or eliminate extraneous transmission paths.

3.2.2.1 *Discussion*—This definition attributes all the power transmitted into the receiving room, by direct and flanking paths, to the area of the test specimen. If flanking transmission is significant, the AOITL will be less than the actual OITL for the specimen.

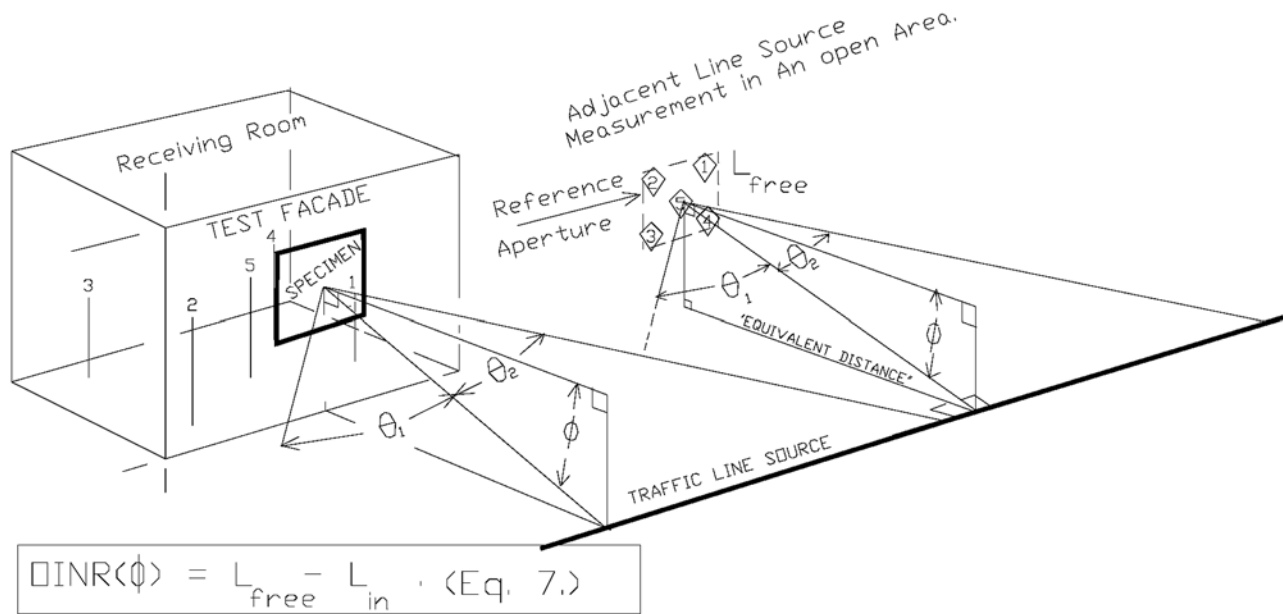

FIG. 4 Geometry—Equivalent Distance Method

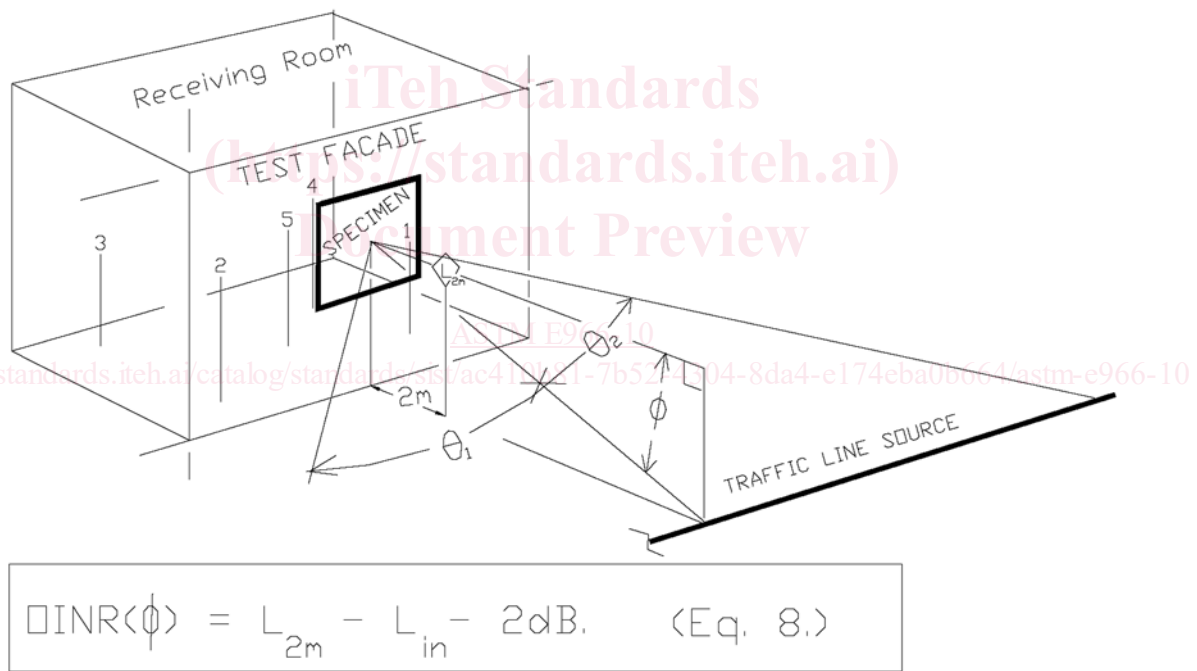

FIG. 5 Geometry—2 m (79 in.) Position Method

3.2.3 *field outdoor-indoor transmission class, FOITC*( $\theta$ ),  $n$ —of a building façade or façade element at a specified angle  $\theta$  or range of angles, the single number rating obtained by Classification E1332 with OITL values.

3.2.4 *outdoor-indoor noise isolation class, OINIC*,  $n$ —of an enclosed space, a single-number rating calculated in accordance with Classification E1332 using values of outdoor-indoor noise reduction.

3.2.4.1 *Discussion*—The direct field sound pressure is from a sound source at a specified angle of incidence,  $\theta$ , as defined in Fig. 2, or a range of angles in the case of a moving source, which would be present at the façade of the room, were the building and its façade not present.—OINIC is an A-weighted level difference based on a specific spectrum defined in Classification E1332.

3.2.5 *outdoor-indoor transmission loss, OITL*( $\theta$ )—of a building façade element in a specified frequency band, ten times the common logarithm of the ratio of airborne sound power per unit area incident on the façade element at a specified angle,  $\theta$ , as defined in Fig. 2, to the sound power transmitted through it and radiated to the interior; the quantity so obtained is expressed in decibels (dB).—outdoor-indoor noise reduction, *OINR*( $\theta$ ),  $n$ — which may or may not be a function of angle  $\theta$  or a range of angles,

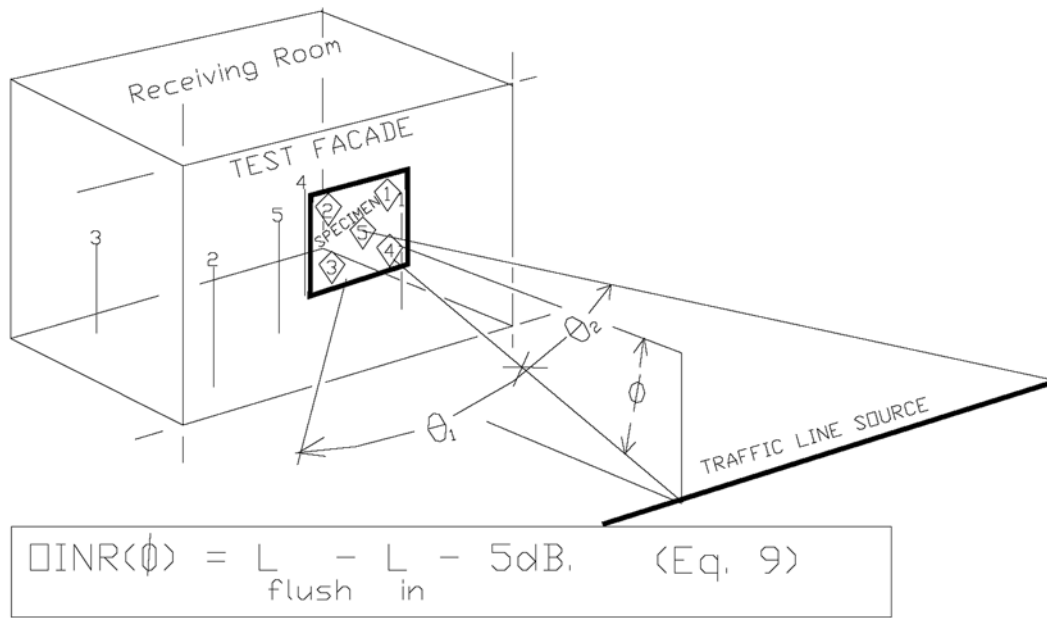

FIG. 6 Geometry and Formulas—Line Source Flush Method

in a specified frequency band the difference between the space-time average sound pressure level in a room of a building and the time-averaged exterior sound pressure level which would be present at the facade of the room were the building and its facade not present.

3.2.5.1 Discussion—The outdoor-indoor noise reduction has been known previously in this guide as the outdoor-indoor level reduction, OILR. For measured data, the OINR ( $\theta$ ) may be used to indicate results at a specific angle ( $\theta$ ) as discussed in 8.5. ONIR may be used to indicate the weighted average of measurements over a range of angles as discussed in 8.6 or a measurement result due to exposure to a line source as discussed in Section 9.

3.2.6 outdoor-indoor transmission loss, OITL( $\theta$ ), (dB),  $n$ —of a building facade or facade element in a specified frequency band, for a source at a specified angle  $\theta$  or range of angles as measured from the normal to the center of the specimen surface, ten times the common logarithm of the ratio of airborne sound power incident on the specimen to the sound power transmitted through it and radiated to the room interior.

3.2.6.1 Discussion—The unqualified term OITL( $\theta$ ) signifies that flanking tests have been performed according to Annex A1 to verify that there was no significant flanking or leakage transmission. In the absence of such tests, the test result may be termed the apparent OITL—AOITL( $\theta$ ) (see 3.2.4.3.2.2).

3.2.6

3.2.7 sound exposure level—\*SEL in decibels where the “\*” denotes the frequency weighting such as CSEL for C-weighting (understood to be A if absent).

3.2.8 one-third octave-band sound exposure—level one-third octave-band SEL( $f$ ), (dB),  $n$ —ten times the logarithm to the base ten of the ratio of a given time integral of squared instantaneous sound pressure in a specific one-third octave-band of center frequency  $f$ , over a stated time interval or event, to the product of the squared reference sound pressure of 20 micropascals and reference duration of one second.

3.2.9 traffic noise—noise emitted by moving transportation vehicles, such as cars, trucks, locomotives, or aircraft.—noise emitted by moving transportation vehicles, such as cars, trucks, locomotives, or aircraft moving along an extended line path.

#### 4. Summary of Guide

4.1 This guide provides procedures to measure the reduction in sound level from the outdoors to an enclosed room. This outside-inside level reduction is a function of angle, OILR ( $\theta$ ), where  $\theta$  is the angle of incidence of the outdoor sound. With further measurements under restricted conditions, a basic property of a facade or facade element, the outdoor-indoor transmission loss, OITL ( $\theta$ ), may be determined. This requires that the conditions of

4.1 This guide provides procedures to measure the reduction in sound level from the outdoors to an enclosed room, the outdoor-indoor level reduction, OINR, with a variety of sources and methods. With further measurements under restricted conditions using a loudspeaker source, a basic property of a facade or facade element, the outdoor-indoor transmission loss, OITL( $\theta$ ), may be determined. This requires that the conditions of Annex A1 be met to demonstrate that flanking of sound around the test specimen is not significant. If it is not possible to meet the conditions of Annex A1, the apparent OITL ( $\theta$ ) is reported. The OILR ( $\theta$ ) and OITL ( $\theta$ ) may reported for a range of angles, the AOITL( $\theta$ ) is reported. These results measured with a loudspeaker will vary with the angle of the source  $\theta$  as measured from the normal to the surface as shown on Fig. 7. The OINR( $\theta$ ), the